

24-1285

UNITED STATES COURT OF APPEALS
FOR THE FEDERAL CIRCUIT

APPLE INC.,

Appellant,

v.

INTERNATIONAL TRADE COMMISSION,

Appellee,

AND

MASIMO CORPORATION, CERCACOR LABORATORIES, INC.,

Intervenors.

Appeal from the United States International Trade Commission in
Investigation No. 337-TA-1276

NONCONFIDENTIAL BRIEF OF APPELLEE
INTERNATIONAL TRADE COMMISSION

RONALD A. TRAUD
Attorney Advisor
Office of the General Counsel
U.S. International Trade Commission
500 E Street, SW
Washington, DC 20436
Telephone (202) 205-3427

DOMINIC L. BIANCHI
General Counsel
Telephone (202) 205-3061

WAYNE W. HERRINGTON
Assistant General Counsel
Telephone (202) 205-3090

Dated: June 28, 2024

PATENT CLAIMS AT ISSUE

U.S. Patent No. 10,912,502 (dependent claim 22, independent claim 28)

19. A *user-worn device* configured to non-invasively measure an *oxygen saturation* of a user, the user-worn device comprising:

a plurality of emitters configured to emit light, each of the emitters comprising at least two light emitting diodes (LEDs);

four photodiodes arranged within the user-worn device and configured to receive light after at least a portion of the light has been attenuated by tissue of the user;

a protrusion comprising a convex surface including *separate openings* extending *through* the protrusion and lined with opaque material, each opening positioned *over* a different one of the four photodiodes, the opaque material configured to reduce an amount of light reaching the photodiodes without being attenuated by the tissue;

optically transparent material within each of the openings; and

one or more processors configured to receive one or more signals from at least one of the four photodiodes and output measurements responsive to the one or more signals, the measurements indicative of the oxygen saturation of the user.

20. The user-worn device of claim 19 further comprising a thermistor.

21. The user-worn device of claim 20, wherein the one or more processors are further configured to receive a temperature signal from the thermistor and adjust operation of the user-worn device responsive to the temperature signal.

22. The user-worn device of claim 21, wherein the plurality of emitters comprise at least four emitters, and wherein each of the plurality of emitters comprises a respective set of at least three LEDs.

...

28. A ***user-worn device*** configured to non-invasively measure an ***oxygen saturation*** of a user, the user-worn device comprising:

a first set of light emitting diodes (LEDs), the first set of LEDs comprising at least an LED configured to emit light at a ***first wavelength*** and an LED configured to emit light at a ***second wavelength***;

a second set of LEDs spaced apart from the first set of LEDs, the second set of LEDs comprising at least an LED configured to emit light at the ***first wavelength*** and an LED configured to emit light at the ***second wavelength***;

four photodiodes arranged in a quadrant configuration on an interior surface of the user-worn device and configured to receive light after at least a portion of the light has been attenuated by tissue of the user;

a thermistor configured to provide a temperature signal;

a protrusion arranged ***above*** the interior surface, the protrusion comprising:

a convex surface;

a plurality of ***openings*** in the convex surface, extending through the protrusion, and aligned with the four photodiodes, each opening defined by an opaque surface configured to reduce light piping; and

a plurality of transmissive windows, each of the transmissive windows extending across a different one of the openings;

at least one opaque wall extending between the interior surface and the protrusion, wherein at least the interior surface, the opaque wall and the protrusion form cavities, wherein the photodiodes are arranged on the interior surface within the cavities;

one or more processors configured to receive one or more signals from at least one of the photodiodes and calculate an oxygen saturation measurement of the user, the one or more processors further configured to receive the temperature signal;

a network interface configured to wirelessly communicate the oxygen saturation measurement to at least one of a mobile phone or an electronic network;

a user interface comprising a touch-screen display, wherein the user interface is configured to display indicia responsive to the oxygen saturation measurement of the user;

a storage device configured to at least temporarily store at least the measurement; and

a strap configured to position the user-worn device on the user.

Appx704–705; Appx706.

U.S. Patent No. 10,945,648 (dependent claims 12, 24, and 30)

8. A *user-worn device* configured to non-invasively determine measurements of a physiological parameter of a user, the user-worn device comprising:

a first set of light emitting diodes (LEDs), the first set comprising at least an LED configured to emit light at a *first wavelength* and at least an LED configured to emit light at a *second wavelength*;

a second set of LEDs spaced apart from the first set of LEDs, the second set of LEDs comprising an LED configured to emit light at the *first wavelength* and an LED configured to emit light at the *second wavelength*;

four photodiodes;

a protrusion comprising a convex surface, at least a portion of the protrusion comprising an opaque material;

a plurality of *openings* provided through the protrusion and the convex surface, the openings aligned with the photodiodes;

a separate optically transparent window extending across each of the openings;

one or more processors configured to receive one or more signals from at least one of the photodiodes and output measurements of a physiological parameter of a user;

a housing; and

a strap configured to position the housing proximate tissue of the user when the device is worn.

...

12. The user-worn device of claim 8, wherein the physiological parameter comprises *oxygen or oxygen saturation*.

...

20. A *user-worn device* configured to non-invasively determine measurements of a user's tissue, the user-worn device comprising:

a plurality of light emitting diodes (LEDs);

at least four photodiodes configured to receive light emitted by the LEDs, the four photodiodes being arranged to capture light at different quadrants of tissue of a user;

a protrusion comprising a convex surface and a plurality of through holes, *each through hole including a window* and arranged *over* a different one of the at least four photodiodes; and

one or more processors configured to receive one or more signals from at least one of the photodiodes and determine measurements of *oxygen saturation* of the user.

...

24. The user-worn device of claim 20, wherein the protrusion comprises opaque material configured to substantially prevent light-piping.

...

30. The user-worn device of claim 20, wherein the protrusion further comprises one or more chamfered edges.

Appx815–816.

TABLE OF CONTENTS

	Page(s)
TABLE OF AUTHORITIES	x
STATEMENT OF RELATED CASES	xv
STATEMENT OF THE ISSUES.....	1
STATEMENT OF THE CASE.....	2
SUMMARY OF THE ARGUMENT	9
ARGUMENT	133
I. STANDARD OF REVIEW.....	133
II. WAIVER	15
III. MASIMO SATISFIED THE TECHNICAL PRONG OF THE DOMESTIC INDUSTRY REQUIREMENT.....	18
A. Prior to the Complaint, Masimo Created Physical Implementations of Prototype Designs that Practice Claims of the Asserted Patents.	19
B. Apple Failed to Show Any Legal Basis Requiring the Commission to Ignore Any of the Evidence Showing that Masimo Satisfied the Technical Prong of the Domestic Industry Requirement.	25
C. Apple’s Remaining Arguments Do Not Address the Commission’s Decision.....	27
IV. MASIMO SATISFIED THE ECONOMIC PRONG OF THE DOMESTIC INDUSTRY REQUIREMENT.....	28
A. The Commission Properly Credited Labor Investments that Led to Developing Domestic Industry Products.	28
B. The Commission Properly Assessed the Amount of Masimo’s Labor Investment in Finding Masimo’s Investments Significant.	32

TABLE OF CONTENTS (cont'd)

	Page(s)
1. Apple Fails to Address an Independent Basis for the Commission’s Conclusion that Masimo’s Investment Was Significant.	32
2. Substantial Evidence Supports the Commission’s Crediting of the Dollar Amount of Masimo’s Investments Because It Is Corroborated and Supported by an Explained Methodology.	33
V. APPLE FAILED TO SHOW THAT THE CLAIMS ARE OBVIOUS OVER LUMIDIGM.	35
A. Apple Failed to Show that the “User-Worn Device”/“Oxygen Saturation” Limitations of the Asserted Claims Would Have Been Obvious.	37
1. The Commission Properly Found that Apple’s Proposed Modification Lacked a Reasonable Expectation of Success and that the Prior Art Did Not Enable the Disputed Limitations.	37
2. Apple Waived Its Meritless “Enablement” Argument, Which, in any Event, Fails to Allege Error in the Commission’s Independent Lack of Reasonable Expectation Finding.	39
3. The Commission Merely Required Apple to Prove Its Obviousness Defense.	40
4. Apple’s Waived “Enablement” Argument Omits Requirements of the Obviousness Standard.	40
5. Apple Fails to Show that Lumidigm Discloses an Invalidating Arm Band or Ankle Bracelet.	41
B. Apple Failed to Show That the “Separate Windows” Limitations Would Have Been Obvious.	42
1. Apple Failed to Show a Reason to Modify Lumidigm to Use “Separate Windows.”	42
2. Apple Failed to Show an “Optically Transparent Material <i>Within</i> Each of the Openings.”	44

TABLE OF CONTENTS (cont'd)

	Page(s)
3. Apple’s “Obvious to Try”/KSR Theory is Waived, Unsupported, and Meritless.	45
VI. APPLE FAILED TO SHOW THAT THE ASSERTED CLAIMS LACK WRITTEN DESCRIPTION	47
A. Apple Failed to Show That the Asserted Claims Lack Written Description Support for the Claimed Arrangement of Structures.	47
1. Apple Waived Its Argument.	47
2. Apple Failed to Show that the Claims Lack Written Description.	49
B. Apple Failed to Show that the Asserted Claims Lack Written Description for the “Matching Wavelengths” Limitations.	53
VII. THE COMMISSION PROPERLY CONSTRUED THE CLAIMS AND FOUND THAT APPLE WATCHES INFRINGE THE ASSERTED CLAIMS	57
A. The Commission Properly Construed the “Over”/“Above” Claim Terms, a Construction Under Which the Accused Apple Watches Indisputably Infringe.	57
B. The Commission Properly Construed the “Openings”/“Through Holes” Terms, a Construction Under Which the Accused Apple Watches Indisputably Infringe.	60
VIII. THE COMMISSION PROPERLY EXERCISED ITS DISCRETION IN REJECTING APPLE’S WAIVED LACHES ARGUMENT	61
A. Apple Waived Its Argument.	62
B. Apple Failed to Show an Unreasonable and Inexcusable Delay.	63
CONCLUSION	66

CONFIDENTIAL MATERIAL OMITTED

Within this brief, confidential material has been redacted on pages 5, 6, 21, and 32, as material that reflects confidential business information of Masimo Corporation and Cercacor Laboratories, Inc. regarding their finances and product testing.

TABLE OF AUTHORITIES

Cases	Page(s)
<i>Alloc, Inc. v. ITC</i> , 342 F.3d 1361 (Fed. Cir. 2003)	2, 14, 18, 24, 34, 38, 39
<i>Arctic Cat Inc. v. Bombardier Recreational Prod. Inc.</i> , 876 F.3d 1350 (Fed. Cir. 2017)	14
<i>Ariad Pharms., Inc. v. Eli Lilly & Co.</i> , 598 F.3d 1336 (Fed. Cir. 2010)	15, 47
<i>Auris Health, Inc. v. Intuitive Surgical Operations, Inc.</i> , 32 F.4th 1154 (Fed. Cir. 2022)	43
<i>Beloit Corp. v. Valmet Oy</i> , 742 F.2d 1421 (Fed. Cir. 1984)	5
<i>Bio-Rad Labs. v. ITC</i> , 996 F.3d 1302 (Fed. Cir. 2021)	26
<i>In re Bogese</i> , 303 F.3d 1362 (Fed. Cir. 2002)	65
<i>Broadcom Corp. v. ITC</i> , 28 F.4th 240 (Fed. Cir. 2022)	28
<i>Broadcom Corp. v. ITC</i> , 542 F.3d 894 (Fed. Cir. 2008)	15, 16, 17
<i>Cancer Rsch. Tech. Ltd. v. Barr Labs., Inc.</i> , 625 F.3d 724 (Fed. Cir. 2010)	62
<i>CFRD Rsch., Inc. v. Matal</i> , 876 F.3d 1330 (Fed. Cir. 2017)	46
<i>Drone Techs., Inc. v. Parrot S.A.</i> , 838 F.3d 1283 (Fed. Cir. 2016)	23
<i>In re Epstein</i> , 32 F.3d 1559 (Fed. Cir. 1994)	41

TABLE OF AUTHORITIES (cont'd)

Cases (cont'd)	Page(s)
<i>Ethicon LLC v. ITC</i> , 2023 WL 3674680 (Fed. Cir. May 26, 2023).....	18
<i>Finnigan Corp. v. ITC</i> , 180 F.3d 1354 (Fed. Cir. 1999)	16, 17, 48
<i>Flash-Control, LLC v. Intel Corp.</i> , 2021 WL 2944592 (Fed. Cir. July 14, 2021).....	48
<i>Graham v. John Deere Co.</i> , 383 U.S. 1 (1966).....	36
<i>Howmedica Osteonics Corp. v. Zimmer, Inc.</i> , 822 F.3d 1312 (Fed. Cir. 2016)	15
<i>Hyatt v. Hirshfeld</i> , 998 F.3d 1347 (Fed. Cir. 2021)	15, 65
<i>Hynix Semiconductor Inc. v. Rambus Inc.</i> , 2007 WL 4209386 (N.D. Cal. Nov. 26, 2007)	65
<i>Intelligent Bio-Sys. v. Illumina Cambridge Ltd.</i> , 821 F.3d 1359 (Fed. Cir. 2016)	14, 41
<i>KSR Int’l Co. v. Teleflex Inc.</i> , 550 U.S. 398 (2007).....	36
<i>In re Kumar</i> , 418 F.3d 1361 (Fed. Cir. 2005)	36, 41
<i>In re Magnum Oil Tools Int’l, Ltd.</i> , 829 F.3d 1364 (Fed. Cir. 2016)	17
<i>Microsoft Corp. v. ITC</i> , 731 F.3d 1354 (Fed. Cir. 2013)	31
<i>Moleculon Rsrch. Corp. v. CBS, Inc.</i> , 793 F.2d 1261 (Fed. Cir. 1986)	26

TABLE OF AUTHORITIES (cont'd)

Cases (cont'd)	Page(s)
<i>Motiva, LLC v. ITC</i> , 716 F.3d 596 (Fed. Cir. 2013)	14, 29
<i>Motorola Mobility, LLC v. ITC</i> , 737 F.3d 1345 (Fed. Cir. 2013)	29
<i>In re Paulsen</i> , 30 F.3d 1475 (Fed. Cir. 1994)	41
<i>Personalized Media Comm'ns, LLC v. Apple Inc.</i> , 57 F.4th 1346 (Fed. Cir. 2023)	62
<i>PharmaStem Therapeutics, Inc. v. ViaCell, Inc.</i> , 491 F.3d 1342 (Fed. Cir. 2007)	36
<i>Philip Morris Prods. S.A. v. ITC</i> , 63 F.4th 1328 (Fed. Cir. 2023)	16, 48
<i>Phillips v. AWH Corp.</i> , 415 F.3d 1303 (Fed. Cir. 2005)	57, 58
<i>Raytheon Techs. Corp. v. Gen. Elec. Co.</i> , 993 F.3d 1374 (Fed. Cir. 2021)	14, 15
<i>Sonos, Inc. v. Google LLC</i> , 2023 WL 6542320 (N.D. Cal. Oct. 6, 2023)	65
<i>Spansion, Inc. v. ITC</i> , 629 F.3d 1331 (Fed. Cir. 2010)	13, 14, 24, 39
<i>Symbol Techs., Inc. v. Lemelson Med., Educ., & Rsch. Found.</i> , 422 F.3d 1378 (Fed. Cir. 2005)	63, 64
<i>Synopsys, Inc. v. Mentor Graphics Corp.</i> , 814 F.3d 1309 (Fed. Cir. 2016)	18
<i>Vivid Techs., Inc. v. Am. Sci. & Eng'g, Inc.</i> , 200 F.3d 795 (Fed. Cir. 1999)	57

TABLE OF AUTHORITIES (cont'd)

Cases (cont'd)	Page(s)
<i>Winbond Elecs. Corp. v. ITC</i> , 262 F.3d 1363 (Fed. Cir. 2001)	15
<i>Zircon Corp. v. ITC</i> , 101 F.4th 817 (Fed. Cir. 2024)	31, 32, 34, 35
 Statutes	
5 U.S.C. § 706.....	13
19 U.S.C. § 1337(a)(2).....	2, 5, 27, 30
19 U.S.C. § 1337(a)(3).....	28, 30, 32
19 U.S.C. § 1337(d)(1).....	8
19 U.S.C. § 1337(f)(1)	8
35 U.S.C. § 112.....	15
 Code of Federal Regulations	
19 C.F.R. § 210.9(a).....	25
19 C.F.R. § 210.10(b)	25, 26
19 C.F.R. § 210.38.....	25, 26
19 C.F.R. § 210.42(d)	25
19 C.F.R. § 210.42(h)	4
19 C.F.R. § 210.43(b)	16, 63
19 C.F.R. § 210.45(c).....	25

TABLE OF AUTHORITIES (cont'd)

USITC Administrative Decisions	Page(s)
<i>Certain Baseband Processor Chips & Chipsets, Transmitter, & Receiver (Radio) Chips, Power Control Chips, & Prod. Containing Same, Including Cellular Tel. Handsets, Inv. No. 337-TA-543, Comm’n Det., USITC Pub. No. 4258 (Oct. 2011), available at 2011 WL 6121182 & and 2011 WL 6175074 (USITC Oct. 1, 2011)</i>	17
<i>Certain Comput. Network Sec. Equip. & Sys., Related Software, Components Thereof, & Prods. Containing Same, Inv. No. 337-TA-1314, 2023 WL 5744218 (Aug. 8, 2023).....</i>	23
<i>Certain Electronic Stud Finders, Inv. No. 337-TA-1221, 2022 WL 834280 (USITC Mar. 14, 2022), aff’d sub nom Zircon Corp. v. ITC, 101 F.4th 817 (Fed. Cir. 2024).....</i>	31, 32
<i>Certain Male Prophylactic Devices, Inv. No. 337-TA-546, Comm’n Op., USITC Pub. No. 4005 (May 2008), available at 2008 WL 2952724 (May 1, 2008).....</i>	4
 USPTO Inter Partes Review Decisions	
<i>Apple Inc. v. Masimo Corp., IPR2022-01274, 2023 WL 1092323 (PTAB Jan. 24, 2023)</i>	44

STATEMENT OF RELATED CASES

The Commission is unaware of any related cases other than those listed in the opening brief of appellant Apple Inc. (“Apple”).

STATEMENT OF THE ISSUES

1. Whether substantial evidence supports the Commission's finding that Masimo created a patent-practicing article by the time the complaint was filed, thus satisfying the technical prong of the domestic industry requirement.

2. Whether substantial evidence supports the Commission's crediting of Masimo's labor investments, which are indisputably significant, thus satisfying the economic prong of the domestic industry requirement.

3. Whether substantial evidence supports the Commission's finding that Apple failed to show that the asserted claims were obvious.

4. Whether substantial evidence supports the Commission's finding that Apple failed to show that the asserted claims lacked written description support.

5. Whether the Commission properly construed the claim terms "over"/"above" and "openings"/"through holes," constructions under which Apple's products indisputably infringe.

6. Whether the Commission properly exercised its discretion in rejecting Apple's prosecution laches defense.

STATEMENT OF THE CASE

The Commission instituted Investigation No. 337-TA-1276, *Light-Based Physiological Measurement Devices and Components Thereof*, based on a complaint filed by intervenors Masimo Corporation and Cercacor Laboratories, Inc. (collectively, “Masimo”). Appx356. Masimo’s complaint alleged violations of section 337 by Apple based on, *inter alia*, Apple’s importation of Apple Watches that infringe U.S. Patent Nos. 10,912,502 (“’502 patent”) and 10,945,648 (“’648 patent,” collectively, “Asserted Patents”). Appx356. The complaint alleged that Masimo had an existing domestic industry and/or was in the process of establishing a domestic industry based on its Masimo Watch project and related investments.¹ *E.g.*, Appx2923–2929; Appx2937; Appx2741–2758. The Commission concluded that Apple violated section 337 as to claims 22 and 28 of the ’502 patent and claims 12, 24, and 30 of the ’648 patent. Appx358.² Apple

¹ To demonstrate a patent infringement-based section 337 violation, a complainant must show that “an industry in the United States, relating to the articles protected by the patent, ... exists or is in the process of being established.” 19 U.S.C. § 1337(a)(2). The domestic industry requirement consists of a “technical prong” and an “economic prong.” *Alloc, Inc. v. ITC*, 342 F.3d 1361, 1375 (Fed. Cir. 2003).

² The investigation also included allegations regarding other claims of the Asserted Patents and claims of U.S. Patent Nos. 10,912,501, 10,687,745, and 7,761,127. Appx356–357. This appeal does not involve those claims.

appeals that final determination. A summary of the Commission proceedings is presented below.³

Domestic Industry—Technical Prong. To satisfy the technical prong of the domestic industry requirement, Masimo relied on its “Masimo Watch” products, including various prototypes (manufactured from 2019–2021) and a consumer product (the W1 Watch, manufactured in December 2021). Appx10; Appx60; Appx306. Each prototype design was part of a continuous design process, each led to the subsequent design, and each was an iteration and improvement of the prior one. Appx308–309. Those designs are: (1) the Circle Sensor (built in October 2019), (2) the Wings Sensor (built in January 2020), (3) the RevA Sensor (built in November 2020), (4) the RevD Sensor (built in April 2021), and (5) the RevE Sensor (first built in May 2021). *E.g.*, Appx308. Prior to the filing of the complaint, each sensor design was fitted into a watch and then subjected to on-wrist testing of its blood oxygen saturation capabilities. *E.g.*, Appx66. The Circle and Wings Sensors relied on an external device to calculate oxygen saturation; the RevA Sensor introduced “onboard processing”; the RevD Sensor introduced a display; and the RevE Sensor introduced improvements to the

³ The Commission disputes several of Apple’s characterizations of the proceedings below in its Statement of the Case, the most relevant of which are discussed in this section and/or the Argument.

optical components. *E.g.*, Appx306–307. At the evidentiary hearing before the administrative law judge (“ALJ”), Masimo introduced physical exhibits and accompanying photographs representing each prototype design and the W1 Watch.⁴

The Commission adopted the ALJ’s findings that Masimo satisfied the technical prong for claim 28 of the ’502 patent based on the RevD and RevE Sensors and for claims 12, 24, and 30 of the ’648 patent based on the RevA, RevD, and RevE Sensors.⁵ Appx425–426; Appx60–65; Appx73–90; *see also* Appx65–73; 19 C.F.R. § 210.42(h). The ALJ (and the Commission) rejected Apple’s arguments that these prototypes were not constructed before the complaint. Appx66–68; Appx73–74; Appx79–80; Appx84; Appx87–90. The Commission

⁴ Circle Sensor: designated as physical exhibit CPX-0021C before the Commission and shown in photographs at Appx65018–65019; Wings Sensor: designated as physical exhibit CPX-0029C before the Commission and shown in photographs at Appx65022–65023; RevA Sensor: designated as physical exhibit CPX-0052C before the Commission and shown in photographs at Appx65024–65025; RevD Sensor: designated as physical exhibit CPX-0058C before the Commission and shown in photographs at Appx65030–65031; RevE Sensor: designated as physical exhibits CPX-0019C, CPX-0020C, and CPX-0065C before the Commission and shown in photographs at Appx65014–65017 and Appx65032–65033; W1 Watch: designated as physical exhibit CPX-0146C before the Commission and shown in photographs at Appx65040–65042.

⁵ The technical prong is satisfied if the domestic industry products practice any claim of the patent. *Certain Male Prophylactic Devices*, Inv. No. 337-TA-546, Comm’n Op., USITC Pub. No. 4005 (May 2008), *available at* 2008 WL 2952724, at *23 (USITC May 1, 2008).

took no position on the ALJ's findings regarding (1) whether the post-complaint W1 Watch can be considered; and (2) whether Masimo had shown a domestic industry in the process of being established. Appx426 (citing 19 U.S.C. § 1337(a)(2); *Beloit Corp. v. Valmet Oy*, 742 F.2d 1421, 1423 (Fed. Cir. 1984); Appx61–64; Appx67 (n.16); Appx90–92; Appx214; Appx307 (n.116); Appx324–329). Thus, if the Court disagrees with the Commission's technical prong finding under review, it should remand on these issues.

Domestic Industry—Economic Prong. For the economic prong, Masimo relied on, in relevant part, its labor investments in researching and developing the Masimo Watch, including the prototypes and the W1 Watch. Appx303–311. The ALJ credited some of these investments, finding \$[[###]] in pre-complaint labor expenditures, and found these investments significant in the context of Masimo's broader research and development efforts. Appx314–323. The ALJ thus found that Masimo satisfied the economic prong. The ALJ rejected Apple's arguments that: (1) Masimo improperly sought to include investments allegedly related to only early, non-patent practicing prototype designs (the Circle and Wings Sensors) (Appx307–309); and (2) the dollar amount of Masimo's labor investments was not reliably quantified (Appx315–318). The Commission adopted the ALJ's reasoning for finding Masimo's quantified investments to be significant, but additionally found the investments quantitatively significant because Masimo's

research and development labor was almost [REDACTED]##[REDACTED]% domestic. Appx426–427. Again, the Commission took no position as to Masimo’s reliance on post-complaint activities or a domestic industry in “the process of being established.” Appx426. Thus, if the Court reverses the Commission, it should remand on these issues.

Non-Obviousness. The Commission affirmed the ALJ’s conclusion that Apple failed to show that the asserted claims were obvious over Lumidigm, alone or combined with other references and/or knowledge in the art. Appx375–412. In doing so, the Commission adopted the ALJ’s findings in substantial part. *See* Appx375–412; Appx118–161. More particularly, the ALJ (and the Commission) rejected Apple’s argument that it would have been obvious to modify Lumidigm’s wristwatch embodiment (Lumidigm’s sole user-worn embodiment and the only embodiment relied upon by Apple) to measure the oxygen saturation of a user, finding instead both that (1) a person of ordinary skill would not have had a reasonable expectation of success in modifying Lumidigm’s wristwatch to arrive at a user-worn device configured to measure oxygen saturation, and (2) the prior art was not enabling of a user-worn device configured to measure oxygen saturation. Appx118–123. With regard to other claim limitations, the Commission affirmed the ALJ as to the prior art not suggesting an “optically transparent material *within* each of the openings,” Appx126–129 (claim 22 of the ’502 patent); but the

Commission reversed the ALJ as to the similar language in claim 28 of the '502 patent and claims 12 and 24 of the '648 patent (Appx136; Appx144; Appx147), finding that Apple had failed to show a reason to modify the prior art to arrive at those limitations. Appx388–402 (also supplementing the ALJ's reasoning as to claim 22 of the '502 patent). In a manner not relevant to this appeal, the Commission modified the ALJ's secondary considerations findings. Appx404–406. The Commission then evaluated the *Graham* factors anew and found that Apple had not shown that the asserted claims were obvious over Lumidigm and combinations therewith. Appx406–408.⁶

Written Description. The ALJ rejected Apple's written description invalidity arguments based on the claimed combination of LEDs, photodiodes, and openings (all asserted claims); but agreed with Apple regarding the limitations that required separate sets of LEDs emitting at first and second wavelengths ('502 patent, claim 28; '648 patent claim 12). Appx161–165; Appx167–170. The Commission adopted the ALJ's first finding, but reversed the second. Appx412–424; Appx357–358.

⁶ If this Court disagrees with the Commission's obviousness decision, it should remand for further findings. For example, the Commission took no position on whether the prior art taught or suggested the "openings"/"through holes" limitations of all claims subject to this appeal. Appx386–387.

Claim Construction and Infringement. The Commission adopted: (1) the ALJ’s claim construction of the “over”/“above” terms of claims 22 and 28 of the ’502 patent and claims 24 and 30 of the ’648 patent; (2) the ALJ’s claim construction of the “openings”/“through holes” terms of all claims subject to appeal; and (3) the ALJ’s related finding that the accused products infringe all claims subject to appeal. Appx31–38; Appx46–47; Appx50–51; Appx56; Appx59–60; Appx357–358.

Prosecution Laches. The Commission adopted the ALJ’s rejection of Apple’s laches defense. Appx175–179; Appx357–358. The ALJ found that Apple had failed to provide evidence to support a finding of an unreasonable or inexcusable delay. Appx177–179. Neither the ALJ nor the Commission addressed whether Apple was prejudiced by any alleged delay. Accordingly, if this Court disagrees with the Commission, it should remand on this issue.

The Commission’s Remedy. To remedy Apple’s section 337 violation, the Commission issued a limited exclusion order and a cease and desist order. *E.g.*, Appx428; Appx435–477; Appx344–355; *see also* 19 U.S.C. §§ 1337(d)(1), (f)(1). In determining to issue those remedial orders, the Commission considered the statutory public interest factors, finding that wearable device users and researchers had access to numerous reasonable substitute devices, Appx450–452, and that the remedial orders would have only a minimal effect on formally planned or ongoing

medical studies (many of which do not use the blood oxygen feature), Appx455–458. Moreover, to prevent any harm to the public health and welfare and consumers from the orders, the Commission provided an exemption for service, repair, and replacement. *E.g.*, Appx477.

Post-Final Determination Proceedings. After the final determination, Apple moved for the Commission and for this Court to stay enforcement of the remedial orders pending appeal. Both motions were denied. Appx27230–27244; ECF 33. Additionally, Customs and Border Protection issued a ruling allowing Apple to import a redesigned version of its products that does not contain the blood oxygen feature. Br. 19; ECF 29. Thus, researchers and consumers have access to Apple Watches having the remainder of the health-related features, and Apple is not prohibited from importing its “flagship” devices.

SUMMARY OF THE ARGUMENT

Domestic Industry—Technical Prong. The Commission properly found that Masimo satisfied the technical prong of the domestic industry requirement. Apple argues only that the domestic industry products were not shown to be “user-worn” or “configured to detect oxygen saturation” prior to the filing of the complaint, and/or were not completed at that time. However, substantial evidence shows that Masimo performed *on-wrist* testing of the *blood oxygen saturation capabilities* of these iterative designs *prior to the complaint*, and each design

passed its respective testing. That these prototypes successfully measured oxygen saturation in *on-wrist* clinical studies prior to the complaint shows that these devices were, prior to the complaint, “user-worn” and “configured to measure an oxygen saturation of a user.” Unable to refute this, Apple conjures up non-existent evidentiary rules to avoid liability, which should be rejected by the Court.

Domestic Industry—Economic Prong. The Commission also properly found that Masimo satisfied the economic prong of the domestic industry requirement. Apple challenges the Commission’s crediting of certain labor investments but does not dispute that if those investments were properly credited they were significant. Apple first alleges that the Commission improperly credited labor investments that indisputably led to patent-practicing prototypes. However, the Commission properly found that such investments “relate to” the domestic industry. Apple also challenges the basis for calculating the dollar amount of labor investments credited by the Commission. However, Apple does not dispute the Commission’s independent, alternative ground for finding Masimo’s labor investments significant. Moreover, substantial evidence supports the Commission’s crediting of the dollar amount because the amount was supported by an explained methodology, corroborated, and found to be a conservative estimate.

Non-Obviousness. The Commission’s non-obviousness conclusion is supported on two independent grounds relevant to all claims subject to appeal:

(1) Apple failed to show that the prior art teaches or suggests the “user-worn device” configured to measure “oxygen saturation” limitations; and (2) Apple failed to show that the prior art teaches or suggests the “separate windows” limitations. As for the “user-worn device” limitations, the Commission properly found that Apple had not shown a reasonable expectation of success or that the prior art was enabling. On appeal, Apple does not seriously dispute the Commission’s underlying findings, instead presenting a waived, meritless argument related to the non-enablement of the prior art that obfuscates its obviousness theory before the Commission. As for the “separate windows” limitations, substantial evidence supports the Commission’s finding that Apple’s evidence about what a person of ordinary skill *could do* did not show by clear and convincing evidence that a person of ordinary skill *would have had* a reason to modify Lumidigm to arrive at these limitations. Again, Apple does not dispute these findings, instead presenting a waived argument related to an alleged small number of predictable alternatives.

Written Description. Apple’s argument that the Asserted Patents lack written description support for the claimed arrangement of structural elements is waived for not being adequately presented in its petition for Commission review. Even if this Court considers Apple’s waived argument, substantial evidence

supports the Commission’s finding that related Figures 3C, 7B, and 13 provide support for the claimed arrangement.

Substantial evidence also supports the Commission’s finding that Apple failed to prove by clear and convincing evidence that the claims lacked written description support for the “matching wavelength” limitations. Apple relied on conclusory expert witness testimony and then on attorney argument alone to explain why Masimo’s citations to the specification did not provide written description support. Additionally, Masimo’s citations to the specification and its expert witness’s testimony tend to show that the disputed limitations have written description support.

Claim Construction and Infringement. The Commission properly construed the “over”/“above” claim terms, rejecting Apple’s unsupported argument that these terms require the claimed features to be arranged vertically relative to the Earth when the claimed device is in use. The Commission properly found that these terms are commonly used words that can be understood by lay judges, and that in the context of the wearable medical equipment field, “over” is commonly used to describe an arrangement where one feature covers another. The Commission further found that the specification does not require any specific orientation of the device and even refers to a material as being “over” a glass layer when that material is depicted *below* the glass layer.

The Commission properly construed the “openings”/“through holes” terms, concluding that, in the context of the patents, the terms do not preclude transparent material placed therein. The Commission reasoned by analogy, for example, that a swimming hole is still a “hole” when it is filled with water, and then found that this analogy holds true in the context of the specification and claims. Apple fails to allege any error in the Commission’s findings and conclusions regarding the intrinsic evidence, and instead points to only a dictionary definition that it did not raise before the Commission.

Prosecution Laches. Apple’s prosecution laches argument is waived, and in any event, the Commission did not abuse its discretion in finding that Apple failed to show an unreasonable and inexcusable delay. The Commission properly considered and rejected Apple’s proffered theory that Masimo tied its patent application filings to Apple Watch release dates. The Commission additionally found that Masimo’s prosecution was legitimate continuing prosecution and Apple failed to show an egregious misuse of the patent system.

ARGUMENT

I. STANDARD OF REVIEW

Commission final determinations are reviewed under the Administrative Procedure Act. 5 U.S.C. § 706; *Spansion, Inc. v. ITC*, 629 F.3d 1331, 1349 (Fed. Cir. 2010). This Court reviews the Commission’s legal determinations *de novo*

and the Commission’s factual findings for substantial evidence. *Spansion*, 629 F.3d at 1343. Under substantial evidence review, the Court “must affirm a Commission determination if it is reasonable and supported by the record as a whole, even if some evidence detracts from the Commission’s conclusion.” *Id.* at 1344. “This [C]ourt generally defers to an agency as fact-finder in assessing the credibility of witnesses.” *Alloc, Inc. v. ITC*, 342 F.3d 1361, 1373 (Fed. Cir. 2003).

Domestic industry may involve both legal and factual questions, *Motiva, LLC v. ITC*, 716 F.3d 596, 600–01 (Fed. Cir. 2013), but this appeal concerns only factual questions.⁷

Obviousness is a legal conclusion based on factual determinations. *Intelligent Bio-Sys. v. Illumina Cambridge Ltd.*, 821 F.3d 1359, 1366 (Fed. Cir. 2016). The scope and content of the prior art, whether there is a reason to modify the prior art, and whether there is a reasonable expectation of success are factual questions, *Arctic Cat Inc. v. Bombardier Recreational Prod. Inc.*, 876 F.3d 1350, 1360–61 (Fed. Cir. 2017). Whether a prior art reference is enabling presents a question of law based on underlying factual findings, *Raytheon Techs. Corp. v.*

⁷ Apple asserts that the Commission’s alleged interpretation of the domestic industry requirement that permits “articles” to be satisfied by CAD drawings presents a legal question. Br. 23, 27–28. However, as explained *infra*, the Commission did not interpret or apply “article” in that manner.

Gen. Elec. Co., 993 F.3d 1374, 1380 (Fed. Cir. 2021), but only factual findings are at issue here.

Claim construction is a legal question which may be based on underlying factual findings. *Howmedica Osteonics Corp. v. Zimmer, Inc.*, 822 F.3d 1312, 1320 (Fed. Cir. 2016).

Satisfaction of the written description requirement of 35 U.S.C. § 112 is a factual question. *Ariad Pharms., Inc. v. Eli Lilly & Co.*, 598 F.3d 1336, 1355 (Fed. Cir. 2010).

Prosecution laches is reviewed for abuse of discretion. *Hyatt v. Hirshfeld*, 998 F.3d 1347, 1359 (Fed. Cir. 2021).

Waiver findings are reviewed for an abuse of discretion. *See Winbond Elecs. Corp. v. ITC*, 262 F.3d 1363, 1370 (Fed. Cir. 2001).

II. WAIVER

As discussed *infra*, many of Apple's arguments are waived and need not be considered by this Court. This Court does not "review" that which was not properly presented to the Commission, and to the extent Apple failed to timely and adequately present arguments below, those arguments are waived. Arguments have been deemed waived when not properly presented to the ALJ in the first instance and/or not presented to the Commission in a petition for review of the ALJ's initial determination. *E.g., Broadcom Corp. v. ITC*, 542 F.3d 894, 901 (Fed.

Cir. 2008); Appx5254 (ALJ Ground Rule 9.2, governing timely presentation of arguments and waiver); Appx5264–5265 (ALJ Ground Rule 13.1, similar); *Finnigan Corp. v. ITC*, 180 F.3d 1354, 1362–63 (Fed. Cir. 1999) (argument waived when not “specifically assert[ed]” in petition for Commission review); *Philip Morris Prods. S.A. v. ITC*, 63 F.4th 1328, 1337 (Fed. Cir. 2023) (“vague suggestions” in petition for review are insufficient to avoid forfeiture); 19 C.F.R. § 210.43(b) (requiring petition for Commission review of ALJ’s determinations to “specify” the alleged error, contain a “concise statement of the [material] facts,” and “present a concise argument providing the reasons that review” is “necessary or appropriate,” and declaring that arguments “not relied on in a petition” “will be deemed to have been abandoned”). Apple has recognized the Commission’s waiver rules and consequences of violating those rules, having repeatedly argued throughout the investigation that Masimo’s arguments should be simply disregarded when waived. *E.g.*, Appx24084–24085; Appx24094; Appx24103; Appx24112; Appx24148; Appx25298–25299; Appx22955 (n.4); Appx22957 (n.7); Appx22958–22959.

Waiver rules are enforced to ensure both orderly proceedings and fairness to affected parties and the Commission. As this Court explained:

[t]he argument at the trial and appellate level should be consistent, thereby ensuring a clear presentation of the issue to be resolved, an adequate opportunity for response and evidentiary development by the opposing party, and a record

reviewable by the appellate court that is properly crystallized around and responsive to the asserted argument; moreover, the agency is not afforded the opportunity to consider the issue in the first instance. Thus, simple fairness to those who are engaged in the tasks of administration, and to litigants, requires as a general rule that courts should not topple over administrative decisions unless the administrative body not only has erred but has erred against objection made at the time appropriate under its practice.

Finnigan, 180 F.3d at 1363; *see also In re Magnum Oil Tools Int'l, Ltd.*, 829 F.3d 1364, 1381 (Fed. Cir. 2016) (agency “must base its decision on arguments that were advanced by a party, and to which the opposing party was given a chance to respond”).

In certain instances, Apple erroneously suggests that its waiver should be excused because the Commission did not make an express waiver finding. *E.g.*, Br. 67 (n.18). However, this Court has declined to consider waived arguments even without an express waiver finding, *see Broadcom*, 542 F.3d at 901,⁸ and for arguments presented to the Commission in a petition for review without having been presented to the ALJ, Apple has recognized that the Commission should

⁸ Neither the Commission’s final determination nor the ALJ’s final determination included a waiver finding regarding the infringement issue in dispute in *Broadcom*. *See Certain Baseband Processor Chips & Chipsets, Transmitter, & Receiver (Radio) Chips, Power Control Chips, & Prod. Containing Same, Including Cellular Tel. Handsets* Inv. No. 337-TA-543, Comm’n Det., USITC Pub. No. 4258 (Oct. 2011), *available at* 2011 WL 6121182 *and* 2011 WL 6175074 (USITC Oct. 1, 2011).

disregard those arguments by simply “declin[ing] to review” the ALJ’s decision. Appx24083. Moreover, the Commission is “not require[d] ... to address every argument raised by a party or explain every possible reason supporting its conclusion.” *Synopsys, Inc. v. Mentor Graphics Corp.*, 814 F.3d 1309, 1322 (Fed. Cir. 2016). Such a requirement for the Commission would be unreasonable, especially here where the Commission’s and ALJ’s decisions were already more than 400 pages. Indeed, the Commission’s analysis does not need to be more extensive than the parties’ treatment below. *Ethicon LLC v. ITC*, 2023 WL 3674680, at *3 (Fed. Cir. May 26, 2023).

III. MASIMO SATISFIED THE TECHNICAL PRONG OF THE DOMESTIC INDUSTRY REQUIREMENT

The test for the “technical prong” of the domestic industry requirement is “essentially [the] same as that for infringement,” involving “a comparison of domestic products to the asserted claims.” *Alloc*, 342 F.3d at 1375. It is thus a factual finding that must be affirmed if supported by substantial evidence, as is the case here.

A. Prior to the Complaint, Masimo Created Physical Implementations of Prototype Designs that Practice Claims of the Asserted Patents.

Substantial evidence supports the Commission’s⁹ finding that Masimo created, prior to the complaint, patent-practicing Masimo Watch articles, such as implementations of the RevA, RevD, and RevE Sensor designs.¹⁰ Thus, contrary to Apple’s assertions, the Commission’s determination was not based on “hypothetical” articles, but on actual ones. Regarding the claim limitations, Apple argues only that the prototypes were not shown to be “user-worn” or “configured to detect oxygen saturation” as of the filing of the complaint, and/or were not completed prior to the complaint. Br. 31–37. However, substantial evidence shows, and Apple does not seriously dispute, that Masimo performed *on-wrist* testing of the *blood oxygen saturation capabilities* of the iterative RevA, RevD, and RevE Sensor designs *prior to the complaint*, and each design passed its respective testing. *E.g.*, Appx66. That these prototypes successfully measured oxygen saturation in *on-wrist* clinical studies prior to the complaint shows that

⁹ Except when necessary to distinguish the ALJ’s findings from the Commission’s, this brief refers to the ALJ’s findings as the Commission’s own findings.

¹⁰ Amici’s assertion that the technical prong requires “meaningful volumes” (Amici Br. 4) is unsupported by authority or the language of Section 337.

these devices practiced the only disputed elements (“user-worn” and “configured to measure an oxygen saturation of a user”).

For each design, Masimo introduced physical exhibits, photographs, CAD renderings and drawings, witness testimony, and test results, proving that the designs were complete and practiced the Asserted Patents prior to the complaint. *E.g.*, Appx40358–40360 (265:15–267:15) (witness testimony regarding, *inter alia*, the RevA and RevD Sensor designs, testing, and test results); Appx40409–40412 (315:16–318:22) (witness testimony regarding, *inter alia*, the RevE Sensor design, testing, and test results); Appx53110–53125 (CAD renderings, drawings, schematics, and test results); Appx53137–53138 (results of on-wrist blood oxygen saturation testing); Appx53222–53234 (schematics); Appx65014–65017 (photographs).

The physical exhibit introduced as representative of the RevA Sensor design was completed in November 2020. *E.g.*, Appx64; Appx40490 (396:2–13); Appx40499–40500 (405:8–406:22); Appx22283 (design “exemplified” by introduced exhibit). The introduced exhibit included a “mechanism for attaching a strap, which it had at one point in time.” Appx40499–40500 (405:8–406:3). The physical exhibit introduced as representative of the RevD Sensor was completed by April 2021 and also had a “mechanism for attaching a strap, which it had at one point in time.” *E.g.*, Appx64; Appx40491 (397:7–24); Appx40500–40501

(406:23–407:18); Appx22284–22285 (design reflected by introduced exhibit).

And at least one physical exhibit introduced as representative of the RevE Sensor design was completed in May 2021. *E.g.*, Appx89; Appx40407–40408 (313:20–314:7); Appx40409 (315:16–19); Appx70486; Appx22284–22285.

Furthermore, pre-complaint completion of the prototype articles is shown by pre-complaint testing of the articles. For each design, Masimo performed a “[redacted] study type [redacted],” in which Masimo evaluated the blood oxygen saturation capabilities of the design by “bring[ing] in volunteers,” “attach[ing] the sensor to their wrist” (*i.e.*, with a strap such that they were “user-worn”), and then performing the study. Appx40344 (251:15–23); Appx40368 (275:19–20) (study repeated for each design change); Appx40363–40368 (270:1–275:3) (October 2020 testing of RevA prototype); Appx40368–40370 (275:23–277:12) (early 2021 testing of a RevD prototype); Appx40410–40412 (316:13–318:22) (June 2021 testing of a RevE prototype); Appx53137–53138 (RevA test results in October 2020 presentation (*see* Appx53107)); Appx53256–53261 (RevE test results). Furthermore, even the RevA Sensor (the earliest patent-practicing prototype) measured oxygen saturation in line with FDA limits for hospital medical devices. Appx40363–40368 (270:1–275:3) (describing RevA test results); Appx40410–40412 (316:13–318:22) (discussing RevE testing results, which were “equivalent to medical devices”); *see also* Appx66–68 (including n.16); Appx88–90 (including

n.21). Each iteration performed “a little bit better.” Appx40368 (275:19–23).

That the prototype designs were tested in on-wrist studies for their oxygen saturation capabilities prior to the complaint shows that these patent-practicing articles were completed prior to the complaint. Thus, contrary to Apple’s assertions (Br. 34), the Commission’s findings were based on more than a theoretical ability to alter the produced exhibits in a patent-practicing manner. Accordingly, substantial evidence supports the Commission’s findings.

Apple does not seriously challenge the above findings, arguing only:

(1) that Masimo did not provide a demonstration of the RevA Sensor measuring blood oxygen saturation or source code for the prototypes; (2) that the introduced RevD Sensor and two of the introduced RevE Sensors were “altered” after the complaint was filed; (3) that Masimo did not show that the RevD and RevE Sensors introduced were completed before the complaint; and (4) that certain cherry-picked anomalies in Masimo’s testing data show that the designs were unable to measure blood oxygen saturation. Br. 32–35. None of Apple’s arguments have merit.¹¹

¹¹ Amici’s challenges likewise have no merit. Amici had no access to the confidential record and yet speculated that the Commission’s findings were based on “questionable, limited, and unreliable domestic industry information.” Amici Br. 1. Much of the evidence relied upon by the Commission was confidential and thus not available to the public (including Amici).

As to Apple’s first argument, Apple cites no authority supporting its assertion that source code or a live demonstration is necessary to show satisfaction of the domestic industry requirement. Moreover, in an unchallenged finding, the Commission found that the absence of this evidence “does not undercut the demonstrated evidence that Masimo tested its devices to measure blood oxygen saturation.” Appx67 (n.17). Additionally, “neither Section 337 nor patent law generally requires any particular type of evidence to prove that an article practices a patent claim.” *Certain Comput. Network Sec. Equip. & Sys., Related Software, Components Thereof, & Prods. Containing Same*, Inv. No. 337-TA-1314, Final ID, 2023 WL 5744218, at *40 (USITC Aug. 8, 2023) (unreviewed in relevant part) (citing, *inter alia*, *Drone Techs., Inc. v. Parrot S.A.*, 838 F.3d 1283, 1300 (Fed. Cir. 2016)).

As to Apple’s second and third arguments, these arguments address only the introduced physical exhibits, and neither Masimo’s argument nor the Commission’s findings were limited thereto, as explained above.¹² Furthermore, the only post-complaint change to the introduced sensors was a firmware update, and a Masimo witness testified that the earlier versions of Masimo’s software

¹² As explained in the next subsection, the Commission properly considered circumstantial evidence.

could determine oxygen saturation, as confirmed by the pre-complaint testing of the RevA, RevD, and RevE discussed above. Appx40439–40441 (345:21–347:4); Appx40570 (476:1–4); Appx40487 (393:12–20); Appx40501–40502 (407:22–408:4); Appx40504 (410:1–4); Appx40499–40500 (405:8–406:11); Appx53137–53138; Appx53256–53261; Appx40343 (250:6–14); Appx40369–40370 (276:12–277:12); Appx40407–40411 (313:14–317:20); Appx89 (nn.22–23). Moreover, while Apple alleges that Masimo’s witness stated only that the RevE exhibits were created “sometime between May and September,” Br. 32 (emphasis and quotations omitted), at least one of these devices was completed and used to measure oxygen saturation by May 2021, prior to the complaint, Appx40409 (315:16–19); Appx89.

As to Apple’s fourth argument, the Commission found credible Masimo’s witnesses’ testimony that the devices measured blood oxygen saturation in line with FDA limits for hospital medical devices (*e.g.*, Appx66; Appx40409–40412 (315:16–318:22)), and, in any event, the Commission should be affirmed if its determination is “reasonable and supported by the record as a whole, even if some evidence detracts from the Commission’s conclusion,” *Spansion*, 629 F.3d at 1344; *Alloc*, 342 F.3d at 1373 (general deference to agency regarding witness credibility).

B. Apple Failed to Show Any Legal Basis Requiring the Commission to Ignore Any of the Evidence Showing that Masimo Satisfied the Technical Prong of the Domestic Industry Requirement.

Unable to refute that, prior to the complaint, Masimo created and implemented three separate patent-practicing designs, Apple conjures up non-existent evidentiary rules for Masimo to have followed in showing that it satisfied the technical prong of the domestic industry requirement that would (1) limit the Commission’s analysis to the complaint; (2) limit the Commission’s analysis to the introduced physical exhibits; and (3) preclude the Commission from relying on circumstantial evidence. Br. 27–37.

However, Apple fails to provide any legal support for any of these self-serving rules. For good reason—Commission final determinations are based on the evidence in the record, which includes those parts of the record Apple wishes did not exist. *E.g.*, 19 C.F.R. §§ 210.38 (defining the record), 210.42(d) (“The [ALJ]’s initial determination shall include: an opinion stating findings (with specific page references to principal supporting items of evidence in the record)...”), 210.45(c) (Commission findings on review must be “based on the record”). Moreover, the evidence in the record is distinct from the complaint,¹³ so

¹³ According to the Commission’s Rules, “[u]pon receipt of a complaint ..., the Commission shall ... examine [it] for sufficiency and compliance,” and if it is, “[a]n investigation shall be instituted.” 19 C.F.R. § 210.9(a); 19 C.F.R.

the Commission’s findings certainly cannot be limited to the complaint. 19 C.F.R. § 210.38(a) (differentiating between “pleadings ... and other documents and things properly filed with the Secretary,” and “evidence admitted into the record.”). Nor is the evidence limited to the representative physical exhibits. Furthermore, this Court has previously affirmed the Commission’s reliance on circumstantial evidence in finding the technical prong of the domestic industry requirement satisfied, *Bio-Rad Labs. v. ITC*, 996 F.3d 1302, 1313–1315 (Fed. Cir. 2021), and “[c]ircumstantial evidence is not only sufficient, but may also be more certain, satisfying and persuasive than direct evidence,” *Moleculon Rsrch. Corp. v. CBS, Inc.*, 793 F.2d 1261, 1272 (Fed. Cir. 1986) (quotation omitted). Thus, there is no rule preventing the Commission from relying on circumstantial evidence, such as evidence other than the introduced physical exhibits.

In sum, Apple’s repeated references to the complaint,¹⁴ fixation on the introduced physical exhibits, and attempted exclusion of circumstantial evidence

§ 210.10(b)(1). Here, the Commission found the complaint sufficient and compliant and instituted an investigation. Appx357–358. Apple neither appeals the Commission’s institution decision, *e.g.*, ECF 34, nor alleges error therein.

¹⁴ Apple’s description of the complaint is also inaccurate. The complaint did not allege a domestic industry based on only CAD drawings depicting a hypothetical article. Rather, the complaint stated that the CAD drawings were “visual representations” (as Apple previously acknowledged); and included a declaration from a Masimo employee describing, based on “personal knowledge,”

miss the mark. *E.g.*, Br. 27 (“... matching the description in the operative complaint”); Br. 36 (“[T]estimony about other ‘RevA’ sensors ... says nothing about the RevA item labeled as CPX-0052—the item on which Masimo relied....”).

C. Apple’s Remaining Arguments Do Not Address the Commission’s Decision.

Apple argues that section 337 requires, for both an “exist[ing]” domestic industry and a domestic industry in the “process of being established” (19 U.S.C. § 1337(a)(2)), that the domestic industry article must be complete before the filing of the complaint. *E.g.*, Br. 24–25. As discussed above, all articles relied upon by the Commission were complete prior to the complaint. The Commission’s final determination took no position on whether a post-complaint article could be considered and no position as to a domestic industry in the process of being established. Appx426. Accordingly, the Commission’s brief also takes no position on these issues.

the pertinent features of the already-developed “Masimo Watch Product” and stating that the attached claim charts “accurately reflect the design of the Masimo Watch Product.” *E.g.*, Appx3733 (complaint); Appx2808–2852 (claim chart); Appx2923–2934 (declaration, declaring, *e.g.*, “[t]he Masimo Watch Product is a watch developed by Masimo” (Appx2924))); Appx13068 (¶89) (Apple’s response to complaint).

IV. MASIMO SATISFIED THE ECONOMIC PRONG OF THE DOMESTIC INDUSTRY REQUIREMENT

“To meet the economic prong, the complainant must demonstrate that its investment in the protected article is ‘significant’ or ‘substantial.’” *Broadcom Corp. v. ITC*, 28 F.4th 240, 250 (Fed. Cir. 2022); 19 U.S.C. § 1337(a)(3). The Commission’s decision was made under 19 U.S.C. § 1337(a)(3)(B), which provides that a domestic industry “shall be considered to exist if there is in the United States, with respect to the articles protected by the patent ... significant employment of labor or capital.” Apple challenges only the Commission’s crediting of certain labor investments, and how the dollar amount of those investments was determined. Br. 37–42. Apple does not dispute that, if those investments were properly credited, then those investments were significant.¹⁵

A. The Commission Properly Credited Labor Investments that Led to Developing Domestic Industry Products.

Apple first alleges “legal error” in the Commission’s crediting of labor investments that indisputably led to patent-practicing prototypes. Br. 37–40. Apple’s arguments have no merit.

¹⁵ At Br. 44 (n.15), Apple (for the first time) “reserves the right” to raise certain constitutional issues. The Commission will respond appropriately if Apple makes any such challenges.

As an initial matter, what Apple alleges to be a legal issue—whether Masimo’s aggregated investments are “with respect to articles protected by the patent”—is a factual one. Br. 36–37; *see also Motorola Mobility, LLC v. ITC*, 737 F.3d 1345, 1351 (Fed. Cir. 2013) (declaring, when considering if investments related to a component of the domestic industry article could be credited, that “substantial evidence supports the Commission’s determination”); *Motiva*, 716 F.3d at 600 (declaring that “this appeal presents only factual issues” when considering whether licensing activities were “directed toward ... development of articles that incorporated [the] patented technology”). That Masimo’s labor investments in developing these patent-practicing articles *also resulted* in earlier iterations that did not yet practice the Asserted Patents does not turn this factual issue into a legal one, nor does it negate that those same labor investments also relate to or are with respect to the patent-practicing prototype designs. But regardless of whether this is a legal or factual question, the Commission’s conclusion is correct.

Apple’s arguments also misconstrue Masimo’s domestic industry case before the Commission and the Commission’s related domestic industry findings. Again, contrary to Apple’s assertions, the complaint did not purport to identify a singular hypothetical Masimo Watch that was merely represented by CAD drawings. Br. 38–39. As discussed *supra* at 27 n.14, the complaint alleged that

the drawings were representative of completed articles. Apple further incorrectly alleges that Masimo sought to show a domestic industry based only on “expenditures in making over a half-dozen prototypes of the W1.” Br. 38–39. Again, not so—the Commission agreed with Masimo’s argument that Masimo made significant pre-complaint investments relating to its broader 2019–2021 Masimo Watch project, which developed patent-practicing articles. *E.g.*, Appx308–309.

Turning to the evidence, the Commission properly found that Masimo’s 2019–2021 aggregated labor investments directed to the Masimo Watch prototypes “relate to” or are “with respect to” articles protected by the Asserted Patents. Appx23 (recognizing legal standard); Appx307–309 (accepting aggregated investments); Appx314–317 (crediting labor investments); 19 U.S.C. § 1337(a)(2)–(3). It is undisputed that the prototypes are not separate products. Appx67 (n.16). It is further undisputed that Masimo’s Circle and Wings Sensors (developed in October 2019 and January 2020, respectively) were “merely ‘iterations’ of a product design that was continuously developed in the years leading up to the filing of the complaint.” Appx308; Appx40436–40439 (342:25–343:7, 345:2–7); Appx40487–40492; Appx40496 (402:2–12); Appx40368 (275:13–276:11). It is also undisputed that research and development activities within the Masimo Watch project directed to earlier, non-patent-practicing prototypes (*e.g.*, the Wings

Sensor) involved both improvements to that earlier prototype and development of features of the patent-practicing prototypes (*e.g.*, the RevA Sensor). Appx308; Appx309 (undisputed finding that development of Circle and Wings Sensors led to development of the RevA, RevD, and RevE Sensors); Apx40488–40492.

Substantial evidence supports each of these findings, as well as the Commission’s finding that activities that led to the creation of an article “relate to” or are “with respect to” that article.

None of Apple’s cited authority provides any basis for precluding reliance on labor that directly led to patent-practicing domestic industry articles. Apple primarily relies on *Microsoft Corp. v. ITC*, 731 F.3d 1354 (Fed. Cir. 2013), and *Certain Electronic Stud Finders*, Inv. No. 337-TA-1221, 2022 WL 834280 (USITC Mar. 14, 2022), *aff’d sub nom Zircon Corp. v. ITC*, 101 F.4th 817 (Fed. Cir. 2024). *See* Br. 38–40. However, *Microsoft* does not address the economic prong. *Microsoft*, 731 F.3d at 1364 (affirming the Commission’s finding that the complainant did not satisfy the technical prong finding). And Apple fails to address the Commission’s proper distinction of *Stud Finders*. *See* Br. 38–39; Appx308 (“[U]nlike the different products at issue in [*Stud Finders*], the evidence indicates that the Masimo Watch prototypes are merely ‘iterations’ of a product design that was continuously developed in the years leading up to the filing of the complaint.”); *see also Zircon*, 101 F.4th at 825 (recognizing that the complainant

in *Stud Finders* was unable to show a domestic industry because it failed to present evidence that would permit the Commission to quantify the amount of investments regarding the numerous disparate articles relied on with respect to any particular patent (citing *Stud Finders*, 2022 WL 834280, at *28)). Unlike in *Stud Finders*, the Commission could (and did) quantify the amount of investments attributable to each Asserted Patent because the same iterative design process led to the development of articles practicing both patents. Moreover, unlike in *Stud Finders*, there are not disparate products at issue here. *E.g.*, Appx67 (n.16).

B. The Commission Properly Assessed the Amount of Masimo’s Labor Investment in Finding Masimo’s Investments Significant.

Apple challenges the dollar amount of labor investments credited by the Commission under 19 U.S.C. § 1337(a)(3)(B). Br. 37–42. However, Apple does not dispute that, if the dollar amount of Masimo’s investments were properly credited, those investments were significant. Apple also does not dispute the Commission’s other quantitative assessment of Masimo’s labor investments and its finding that, based on that assessment, Masimo’s labor investments were significant.

1. Apple Fails to Address an Independent Basis for the Commission’s Conclusion that Masimo’s Investment Was Significant.

In an undisputed finding, the Commission found that Masimo’s labor investments were significant because the identified employment of labor is almost

[[##]] % domestic, as nearly all the research and development of the Masimo Watch occurred in the United States. Appx426 (citing Appx322; Appx22558; Appx40415–40416 (321:23–322:5)); Appx40598 (504:9–25); Appx40415–40416 (321:23–322:5). Because Apple fails to allege error in this independent basis for finding Masimo’s investments significant, the Commission should be affirmed.

2. Substantial Evidence Supports the Commission’s Crediting of the Dollar Amount of Masimo’s Investments Because It Is Corroborated and Supported by an Explained Methodology.

In crediting \$[[###]] in labor investments, the Commission found that Masimo employed more than [[#]] domestic employees and executives to develop the prototypes. *See* Appx316; Appx40586 (492:20–493:7). The Commission further found that a team of Masimo employees led by Micah Young (Masimo’s CFO) calculated this total by multiplying each employee’s salary by the percentage of time the respective employee devoted to the Masimo Watch project. *See* Appx316–317; Appx40586 (492:20–493:7). The sum of the labor investments was presented in detailed spreadsheets. *See* Appx53492; Appx53497; Appx53499. The percentage of time devoted to the project was a conservative estimate based on information from Masimo employees (including engineering leaders and executives) and corroborated by Mr. Young. Appx40580 (486:16–21); Appx40586–40588 (492:20–494:17) (explaining methodology and providing corroboration); Appx40603 (509:5–25) (corroborating information); Appx40613

(519:21–24) (corroborating information); Appx40341 (248:20–23) (Mr. Al-Ali’s role); Appx40416–40419 (322:6–325:23) (Mr. Al-Ali, confirming provision of estimates); Appx70611 (129:1–14) (Mr. Muhsin confirming provision of estimates); Appx53492. This information was further corroborated by photographs of Masimo’s domestic operations and Masimo’s financial expert’s (Mr. McGavock’s) independent verification of Masimo’s domestic activities. *See* Appx54064–54266 (photographs); Appx40526–40527 (432:22–433:5); Appx40629–40632 (535:24–538:3) (McGavock verification). Thus, substantial evidence supports the Commission’s findings. *See Zircon*, 101 F.4th at 828 (applying substantial evidence review to determination of whether investment evidence is credible, and recognizing that an explained methodology and employee corroboration is sufficient for reliability); *Alloc*, 342 F.3d at 1373 (general deference to agency regarding witness credibility).

Apple’s criticisms of the Commission’s reliance on Masimo’s data are meritless. First, Apple asserts that the sum of Masimo’s credited labor investments was based on an “unexplained methodology” and was “wholly invented,” and Mr. Young was not aware of the criteria used to make the time estimates. Br. 41–42. However, as discussed above, Mr. Young testified about the methodology used and that the time estimates were obtained with the input of Masimo’s executives and leaders. *E.g.*, Appx40580 (486:16–21); Appx40586–40587 (492:20–493:7);

Appx40613–40614 (519:21–520:7). Second, Apple argues that the Commission should have disregarded the spreadsheets because they are not “contemporaneous documents.” Br. 41. However, contemporaneous documentation is not required to credit labor investments, *Zircon*, 101 F.4th at 828–29, as “most people do not document their daily affairs in contemplation of possible litigation,” Appx317 (quotations omitted). Complainants in section 337 investigations can and often do rely on documentary evidence created to summarize more complex or voluminous corporate records. Third, Apple argues that Masimo’s economic expert did not independently verify Masimo’s data. Br. 42. However, as discussed above, Mr. McGavock verified Masimo’s domestic operations with an on-site visit, Appx40629–40632 (535:24–538:3), and Masimo’s investments were sufficiently corroborated. Last, Apple complains that Masimo’s executives estimated the same time percentage each quarter, Br. 41, but if anything, Masimo’s time allocations undercounted Masimo’s executive labor. Appx40587–40588 (493:8–494:17) (Mr. Young, explaining that Mr. Kiani spent more time on the Masimo Watch project than indicated in the spreadsheets).

V. APPLE FAILED TO SHOW THAT THE CLAIMS ARE OBVIOUS OVER LUMIDIGM

Obviousness is a question of law based on the following underlying factual questions: “(1) the scope and content of the prior art, (2) the level of ordinary skill in the art, (3) the differences between the claimed invention and the prior art, and

(4) objective indicia of non-obviousness.” *Graham v. John Deere Co.*, 383 U.S. 1, 17–18 (1966). Relevant to the “differences between the prior art and the claimed invention” is whether a person of ordinary skill “would have had reason to attempt to make the ... device ... and would have had a reasonable expectation of success in doing so.” *PharmaStem Therapeutics, Inc. v. ViaCell, Inc.*, 491 F.3d 1342, 1359–60 (Fed. Cir. 2007); *KSR Int’l Co. v. Teleflex Inc.*, 550 U.S. 398, 418–21 (2007). Moreover, a patentee may rebut a showing of *prima facie* obviousness with evidence that “the prior art does not enable the claimed subject matter.” *In re Kumar*, 418 F.3d 1361, 1368 (Fed. Cir. 2005).¹⁶

The Commission’s non-obviousness conclusion is supported on two independent grounds relevant to all claims subject to appeal: (1) Apple failed to show that the “user-worn device” configured to measure “oxygen saturation” limitations of all asserted claims would have been obvious; and (2) Apple failed to show that the “separate windows” limitations of all asserted claims would have been obvious. If the Court agrees with the Commission as to one ground, it need not address the other. Each ground is discussed separately below.

¹⁶ Apple’s statement of the obviousness standard, Br. 46–48, omits that evidence of a lack of reasonable expectation of success and/or lack of enablement of the prior art can defeat an obviousness defense, the two grounds on which the Commission based its determination as to the “user-worn” limitations.

A. Apple Failed to Show that the “User-Worn Device”/“Oxygen Saturation” Limitations of the Asserted Claims Would Have Been Obvious.

1. The Commission Properly Found that Apple’s Proposed Modification Lacked a Reasonable Expectation of Success and that the Prior Art Did Not Enable the Disputed Limitations.

The Commission should be affirmed because substantial evidence supports its findings related to a lack of reasonable expectation of success and non-enablement of the prior art.

The asserted claims require “a user-worn device” configured to measure an “oxygen saturation of a user.”¹⁷ Apple’s brief omits the obviousness theory it presented to the Commission. To show that Lumidigm taught a “user-worn” device before the ALJ, Apple pointed to Lumidigm’s wristwatch, the only user-worn device in that reference. *E.g.*, Appx22703–22773; Appx118–123; Appx94–97. Apple’s theory then sought to combine that wristwatch with Lumidigm’s separate disclosure of a biometric sensor that may be used to measure oxygen saturation. *E.g.*, Appx118; Appx22703. Thus, Apple chose an obviousness theory that relied on showing measuring oxygen at the wrist.

In rebuttal, Masimo presented persuasive evidence and argument showing that: (1) a person of ordinary skill would not have had a reasonable expectation of

¹⁷ Appx704 (46:22–23); Appx705 (47:13–14); Appx815 (46:15–16, 46–48).

success in modifying Lumidigm’s wristwatch to arrive at a user-worn device configured to measure oxygen saturation, and (2) that the prior art was not enabling of a user-worn device configured to measure oxygen saturation.

Appx118–119. The ALJ (and the Commission) adopted Masimo’s argument. In doing so, the ALJ and Commission found credible and persuasive Masimo’s evidence describing the significant challenges at the time of the invention with measuring blood oxygen at the wrist, including testimony from Apple’s own engineers. Appx41094–41095 (998:21–999:6) (declaring that the wrist is “just an incredibly different beast”); Appx41108–41109 (1012:12–1013:6) (Apple engineer declaring regarding pulse oximetry at the wrist that he “did not know if it could be done”); Appx53017–53018 (166:4–167:5) (“The wrist is one of the most difficult places on the body to do almost every physiological measurement.”); *see also* Appx120–123 (including n.44) (citing Appx52605–52606 (118:4–119:8); Appx52940 (108:13–21); Appx51912; Appx41078–41079 (982:3–983:12)); Appx133; Appx143; Appx145–146. Thus, the Commission should be affirmed because substantial evidence supports its findings.

Apple does not seriously dispute the above findings. Br. 45–50. Apple points to only a portion of its expert’s (Dr. Warren’s) contrary testimony. Br. 49. However, the Commission found that testimony not credible, Appx121–122, and this Court generally defers to an agency regarding credibility, *Alloc*, 342 F.3d at

1373. Moreover, the Commission’s “reasonable and supported” determinations should be affirmed “even if some evidence detracts from the Commission’s conclusion.” *See Spansion*, 629 F.3d at 1344.

2. Apple Waived Its Meritless “Enablement” Argument, Which, in any Event, Fails to Allege Error in the Commission’s Independent Lack of Reasonable Expectation Finding.

Unable to challenge the Commission’s supported findings, Apple relies on a series of waived, unsupported, and meritless arguments premised on the notions that the Commission erred by requiring the prior art to disclose and enable an unclaimed limitation and requiring “the prior art to enable more than the patents disclose.” Br. 45–49. Apple concedes that it did not present these arguments to the ALJ, instead asserting that it could not have foreseen the ALJ’s alleged “error.” Br. 46 (n.16); *see also, e.g.*, Appx17056–17057 (argument not in brief); Appx17061–17062 (same); Appx22712–22713 (same). However, the ALJ’s ruling was fully foreseeable because the ALJ accepted Masimo’s clearly-presented, persuasive arguments. Apple could have argued to the ALJ that Masimo’s argument improperly focused on the “wrist,” but it chose not to, instead accepting the premise by presenting the evidentiary argument that a person of ordinary skill could have modified Lumidigm’s wristwatch to measure blood oxygen at the wrist. *E.g.*, Appx22986–22988; Appx121–122 (Commission considering and rejecting Apple’s argument based on Dr. Warren’s testimony). Thus, Apple’s argument

here is waived. *See supra* Argument Part II. In any event, this waived argument fails to address the Commission’s independent reasoning regarding lack of reasonable expectation of success and, to the extent it addresses the Commission’s lack of enablement reasoning, it is meritless, as discussed next.

3. The Commission Merely Required Apple to Prove Its Obviousness Defense.

Apple’s challenge to the non-enablement reasoning is premised on a misunderstanding of the Commission’s decision. *See* Br. 47–48. More specifically, Apple asserts that the Commission erred because, among the ALJ’s many statements in rejecting Apple’s evidence, the ALJ found Apple’s proffered prior art deficient because it did not enable oxygen measurements at the wrist. *Id.* Apple points out that the claims do not require oxygen measurements “at the wrist.” But, as noted above, it was Apple who put “at the wrist” at issue because Apple relied on the Lumidigm wristwatch to show the “user-worn” limitation. What Apple is complaining about is that the Commission simply required Apple, who had the burden of proof, to prove its own theory. There is no error in requiring Apple to prove its defenses, and Apple cites none.¹⁸

¹⁸ This Court has previously affirmed the PTAB’s non-obviousness conclusion based on the unclaimed feature of “quantitative deblocking” because the obviousness theory presented relied on a desire to achieve quantitative

Apple acknowledges that it cannot cite any legal authority supporting its alleged error, instead relying on “[t]aking ... [obviousness and enablement] principles together.” Br. 45–47. However, Apple critically overlooks that obviousness requires a reasonable expectation of success and enabling prior art, *Kumar*, 418 F.3d at 1361; *Intelligent Bio-Sys.*, 821 F.3d at 1368, requirements not met by Apple here and not negated whether or not an asserted patent can also be challenged on non-enablement grounds (a challenge which Apple has chosen not to make here). Thus, *Epstein* and *Paulsen* have no applicability here even if Apple timely-raised an argument based on them, and in any event, do not purport to pronounce any broad legal principles contrary to those the Commission applied here. See *In re Epstein*, 32 F.3d 1559, 1568 (Fed. Cir. 1994); *In re Paulsen*, 30 F.3d 1475, 1481 n.9 (Fed. Cir. 1994).

4. Apple Fails to Show that Lumidigm Discloses an Invalidating Arm Band or Ankle Bracelet.

Last, as part of its untimely argument, Apple alleges that Lumidigm discloses the user-worn limitations if Lumidigm’s wristwatch could “take a blood oxygen measurement anywhere on the body” and the “wristwatch” could be worn

deblocking, but evidence showed that successful quantitative deblocking would not have been reasonably expected. *Intelligent Bio-Sys.*, 821 F.3d at 1368.

on the upper arm or ankle. Br. 48–49. However, Lumidigm discloses a wristwatch, not an arm band or ankle bracelet. Moreover, Apple relies only on attorney argument, failing to point to any disclosure in Lumidigm of using the wristwatch anywhere but the wrist, and a wristwatch is not sized to fit an upper arm or ankle. Furthermore, because modifying the Lumidigm wristwatch to measure blood oxygen at the intended location (the wrist) is not obvious, it is also not obvious to modify that wristwatch to measure blood oxygen at an unintended location (the upper arm or ankle).

B. Apple Failed to Show That the “Separate Windows” Limitations Would Have Been Obvious.

1. Apple Failed to Show a Reason to Modify Lumidigm to Use “Separate Windows.”

Substantial evidence supports the Commission’s finding that Apple did not show by clear and convincing evidence a reason to modify Lumidigm to arrive at the “separate windows” limitations.¹⁹ To show that these limitations were obvious, Apple relied on Lumidigm’s disclosure that “[o]ne embodiment of the sensor incorporates an optical relay (not shown) between the sensor surface 39 and the skin 40,” Appx70412 (8:19–8:26), and asserted that examples of such relays

¹⁹ The asserted claims require, for example, “a plurality of transmissive windows, each of the transmissive windows extending across a different one of the openings.” *E.g.*, Appx705 (48:1–3); Appx704 (46:38–39); Appx815 (45:63–64, 46:43–45).

include “fiber-optic face plates and tapers, individual optical fibers and fiber bundles ..., and other mechanisms known to one of skill in the art.” Appx22717–22718; Appx23256–23257. Apple asserted that one would use a faceplate to transfer light and protect the detector from debris or use a fiber bundle to optimize the detection process. Appx22718. To show that one would arrive at separate windows, Apple relied only on its expert testimony about what a person of ordinary skill “*could*” do. *E.g.*, Appx41318–41319 (1221:16–1222:25) (“[Y]ou could use a single faceplate for multiple openings or you could do an individual....”); Appx41332–41333 (1235:20–1236:2); Appx395.²⁰ Based on Apple’s evidence, the Commission properly rejected Apple’s argument because “[t]he motivation-to-combine inquiry asks whether a skilled artisan not only could have made but would have been motivated to make the combinations.” *Auris Health, Inc. v. Intuitive Surgical Operations, Inc.*, 32 F.4th 1154, 1158 (Fed. Cir. 2022) (quotation omitted); Appx395–396.

The Commission additionally found Apple’s obviousness theory unpersuasive because it failed to explain why using *separate* windows was consistent with Apple’s theory for its other asserted motivations for modifying

²⁰ Apple does not dispute the Commission’s finding regarding the relied upon testimony. Br. 50–54.

Lumidigm. Appx396–398. Apple fails to assert any error in this finding. *See* Br. 50–54. Below, Apple argued that a person of ordinary skill would have been motivated to arrive at both a “protrusion” with “a convex surface” and a “plurality of openings in the convex surface extending through the protrusion” to achieve “ergonomic features that allow for good optical and mechanical coupling” between the device and the user’s tissue. *E.g.*, Appx22707–22708; Appx22725. But as the Commission found, Apple provided no explanation, let alone evidence, for why a person of skill would have modified the Lumidigm wristwatch to use separate windows in a way that was consistent with the goal of achieving improved contact and ergonomics. Appx395; *see also* Appx397–398. Indeed, a series of separate bumps on the sensor head surface caused by separate individual face plates, optical fibers, or optical fiber bundles seems likely to worsen contact and ergonomics. For this additional reason, and as the USPTO found, Apple’s arguments appeared “grounded in hindsight,” and were not sufficient to show obviousness by clear and convincing evidence. Appx396–398 (quoting *Apple Inc. v. Masimo Corp.*, IPR2022-01274, 2023 WL 1092323, at *8 (PTAB Jan. 24, 2023)).

2. Apple Failed to Show an “Optically Transparent Material *Within* Each of the Openings.”

The Commission’s finding that Apple failed to show that Lumidigm teaches or suggests the specific requirement of claim 22 of the ’502 patent of an “optically transparent material *within* each of the openings” is *further* supported by

substantial evidence because Apple failed to identify this limitation in Lumidigm. *E.g.*, Appx128–129. It is undisputed that Lumidigm discloses an optical relay “between the sensor surface 39 and the skin 40,” not “within” the openings. *E.g.*, Appx128–129 (citing Appx70412 (8:19–8:26)). Apple’s implication that its expert relied on knowledge in the art to modify Lumidigm to arrive at that claim limitation, Br. 54, is inconsistent with the record. While Apple’s witness alleged that an optically transparent material “in each of the openings” is “quite well-known,” his only basis was Lumidigm. Appx41318–41319 (1221:18–1222:16). In response to the direct question, “How does Lumidigm teach this [element]?” Apple’s witness specified only the passage of Lumidigm considered and rejected by the Commission. Appx41318–41319 (1221:18–1222:16) (“Lumidigm states in column 8....”). Thus, substantial evidence supports the Commission’s finding.

3. Apple’s “Obvious to Try”/KSR Theory is Waived, Unsupported, and Meritless.

On appeal, Apple argues that the separate windows limitations were obvious because using separate windows was allegedly one of only two ways to modify Lumidigm to cover multiple openings. Br. 50–54. Apple concedes that it did not present this “obvious to try”/KSR argument to the ALJ, instead mistakenly believing that raising this argument as an alternative ground of affirmance in its response to Masimo’s petition for Commission review avoids forfeiture. Br. 53–54

(n.17). However, Apple's argument was untimely and thus properly disregarded.

See supra Argument Part II.²¹

Even if Apple's argument were considered, Apple has not shown that there are only two possible, predictable solutions. Apple points to testimony asserting only that a person of ordinary skill could use one option or another option. Br. 52–53. That is not the same as there being only two options. There are clearly more than two options at least because a single window could be used to cover some but not all openings, and separate windows could be used to cover the remainder. Additionally, Apple points to no evidence showing that there is a finite number of *predictable* solutions (unsurprising because Apple never presented this argument to the ALJ). Br. 52–53. And again, Apple's theory is unpersuasive because it failed to even allege that a person of ordinary skill who modified the Lumidigm wristwatch to have a convex surface in order to improve contact and ergonomics would be motivated to use separate face plates, optical fibers, or optical fiber bundles.

²¹ Apple cites *CFRD Research* in an attempt to excuse its waiver. However, there, the petitioner timely presented its obviousness argument to the USPTO. *CFRD Rsch., Inc. v. Matal*, 876 F.3d 1330, 1346–48 (Fed. Cir. 2017).

VI. APPLE FAILED TO SHOW THAT THE ASSERTED CLAIMS LACK WRITTEN DESCRIPTION

To show that the asserted claims are invalid for lack of written description, Apple was required to show by clear and convincing evidence that the specification did not “reasonably convey[] to those skilled in the art that the inventor had possession of the claimed subject matter as of the filing date.” *Ariad*, 598 F.3d at 1351. Apple failed to do so.

A. Apple Failed to Show That the Asserted Claims Lack Written Description Support for the Claimed Arrangement of Structures.

1. Apple Waived Its Argument.

Apple’s argument that the asserted claims lack written description support for the claimed arrangement of structures is waived for not being specifically presented in its petition for Commission review. *See supra* Argument Part II.; Appx23598–23714; Appx23712; Br. 55–57. Apple will likely respond that its broad assertion that the ALJ “erred in finding written description support for the claimed combinations (all claims),” Appx23712, preserved this argument. However, this single paragraph was part of a four-page section of its petition that purported to address eight separate alleged errors in the ALJ’s decision, but did so in a conclusory, non-specific manner that did not provide the Commission any real “opportunity for correction” of any alleged errors and did not provide Masimo any

real opportunity to respond.²² See *Finnigan*, 180 F.3d at 1362; *Philip Morris*, 63 F.4th at 1337 (“vague suggestion[s]” are insufficient). Nowhere in Apple’s conclusory paragraph does Apple cite to the claim limitations on which it bases its argument, the Commission’s decision (let alone a specific finding or conclusion), the Asserted Patents, witness testimony, or binding legal authority. Appx23712. The only cited evidence was to Lumidigm, the *prior art*, which Apple does not even rely on now in its *four-page* argument to this Court.

²² Apple declared only:

The Poeze specification fails to disclose a single embodiment containing all the claimed limitations. While the ID identified various limitations dispersed throughout the specification, it erroneously found that they belong to the same embodiment by citing to generic language providing that one embodiment can mix-and-match between different sensors. The ID’s finding cannot be squared with its treatment of the prior art, and specifically Lumidigm, which expressly confirms that its wristwatch embodiment can include any of the disclosed sensor geometries. [Lumidigm] at 11:64–12:2. This contrast is particularly significant given that combining different elements of the prior art is permitted when determining whether the prior art teaches the claimed invention, but it is not permitted when analyzing whether the asserted patent provides an adequate written description. *Flash-Control, LLC v. Intel Corp.*, No. 2020-2141, 2021 WL 2944592, at *3–4 (Fed. Cir. July 14, 2021) (“[T]he specification must present each claim as an integrated whole. ... A patent owner cannot show written description support by picking and choosing claim elements from different embodiments....”).

Appx23712.

2. Apple Failed to Show that the Claims Lack Written Description.

In any event, substantial evidence supports the Commission’s finding that Apple failed to show that Masimo did not possess the claimed combination of LEDs, photodiodes, protrusion, openings, and opaque material. *See* Appx161–165. These claimed features are all contained within the described sensor, depicted in schematic form in Figure 1 and as a component of a handheld device in Figures 2A–2D. *E.g.*, Appx507–511; Appx574 (5:44–51). The sensor and components thereof are described in more detail with reference to the remainder of the figures, including Figure 3C (depicting certain features of a sensor 301, including windows having conductive glass over separate photodetectors), Figure 7B (depicting, in a cross-sectional view, the arrangement of the windows, conductive glass, and photodetectors within a sensor 701), and Figure 13 (depicting a process of collecting data using the described sensors). The specification directly links these figures—the sensor depicted in Figure 3C can have the arrangement of Figure 7B, and that described sensor can be used in the handheld device of Figures 2A–2D, implemented in the schematic of Figure 1, and used in the process of collecting data using the sensors of Figure 13. *E.g.*, Appx540; Appx580 (18:39–42);

Appx584 (26:21–27); Appx588 (33:18–21); Appx163.²³ Thus, “Figure 3C and Figure 7B are not distinct embodiments.” Appx164.

Figure 3C (below) depicts a convex *protrusion* 305 having *four separate openings* each having *separate windows* 320–323, and positioned over *four photodiodes* 316 (depicted in Figure 3E in the same pattern as the windows). *E.g.*, Appx514; Appx581 (19:38–45) (referring to Figure 3E); Appx581 (20:25–26) (same); Appx516; Appx582 (22:36–39).

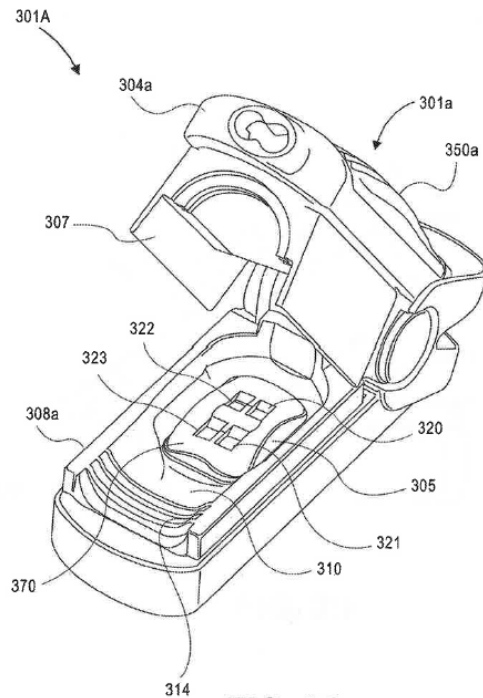

FIG. 3C

²³ The specification additionally directly links Figures 1–3 to the components described in greater detail in Figures 4, 6, 11, and 12, and the process of using a data collection system of Figure 13. *E.g.*, Appx518; Appx520–521; Appx528–540; Appx583 (23:30–32, 24:9–12); Appx586 (29:18–23); Appx588 (33:18–21).

Appx514; Appx574 (5:52–55, 6:10–12). While Figure 3C does not include reference numbers for emitters/LEDs, emitters are contained in emitter shell 304a, Appx580 (18:60–62), and the specification overwhelmingly teaches using “a plurality of LEDs” or multiple sets of LEDs as the emitters. *E.g.*, Appx573 (4:55–57); Appx576 (9:57–63); Appx 577–578 (12:5–13:57); Appx586–587 (29:18–23, 29:62–31:9); Appx588 (33:30–34:48). Indeed, among the emitter types mentioned (LEDs, incandescent sources, and laser diodes), incandescent sources are mentioned once, and lasers are mentioned only three times. The specification further explains that the protrusion can be *opaque* and the openings can have an opaque surface. Appx581 (19:49–20:15) (the windows can include “shielding, such as an embedded grid of wiring,” which can be a “perforated metal sheet”); Appx581 (20:49–51) (the “protrusion 305 can be made from a rigid material, such as *hard plastic* or *metal*,” *i.e.*, opaque (emphasis added)); *see also* Appx575 (7:65–8:1) (referring to hard plastic as “opaque plastic”). Thus, Figure 3C alone includes the claim elements in the claimed arrangement.

To the extent Figure 3C does not disclose all elements, the additional detail provided for the Figure 3C embodiment in the directly-related Figures 7B and 13 do. For example, Figure 3C recites that conductive glass can be used for the separate windows, Appx581 (19:56–58), and Figure 7B (below) provides detail for that arrangement.

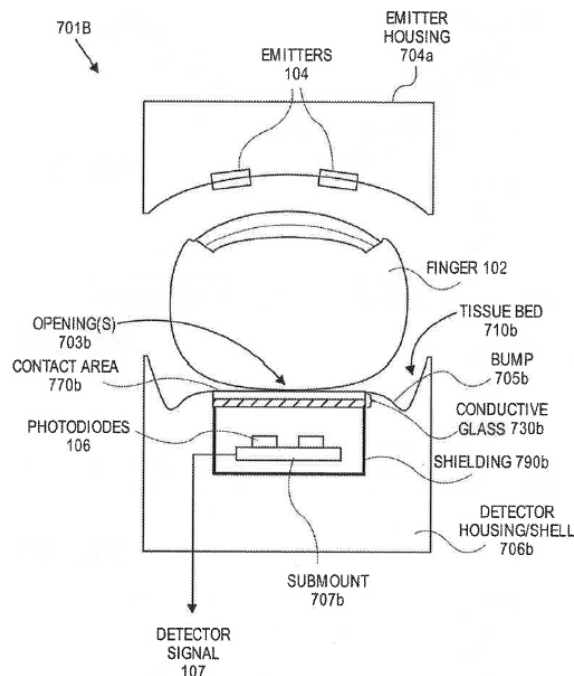

FIG. 7B

Appx523; Appx585 (27:13–41); Appx162. Figure 7B depicts a cross-sectional (or block diagram) view of the *LEDs* (emitters 104), *photodiodes* (106), *protrusion* with a convex surface (bump 705b), *openings* 703b (each of which “can include a *separate window* of conductive glass 703b”), and a shielding enclosure 709b (which can include an “*opaque material*”). Appx585 (27:13–29) (emphases added); Appx584–585 (26:64–27:3). To the extent Figure 7B itself includes only two emitters/photodiodes, that is because it is a cross-sectional view. Moreover, as noted above, (1) the specification teaches that each emitter can itself include a set of LEDs (*e.g.*, Appx573 (4:55–57); Appx577–578 (12:5–13:57)), and thus showing two emitters shows at least four LEDs; (2) Figure 7B provides further detail of the 2x2 grid pattern of photodiodes in Figures 3C and thus Figure 7B contains four

photodiodes; and (3) the number of emitters can equal the number of detectors (Appx588 (33:37–39); Appx540), such that Figure 7B provides for four sets of LEDs. Thus, substantial evidence supports the Commission’s conclusion that Apple failed to show by clear and convincing evidence that Masimo lacked possession of the claimed arrangement.

B. Apple Failed to Show that the Asserted Claims Lack Written Description for the “Matching Wavelengths” Limitations.

Substantial evidence supports the Commission’s finding that Apple failed to show by clear and convincing evidence that the “matching wavelength” limitations of claim 28 of the ’502 patent and claim 12 of the ’648 patent lack written description.²⁴ *See* Appx419–424. The Commission properly found that Apple “relied on conclusory expert witness testimony and then on attorney argument alone to explain why [Masimo’s] citations to the specification did not provide written description support, and [Masimo’s] citations to the specification and its

²⁴ These claims recite, for example, “the first set of LEDs comprising at least an LED configured to emit light at a first wavelength and an LED configured to emit light at a second wavelength,” and “the second set of LEDs comprising at least an LED configured to emit light at the first wavelength and an LED configured to emit light at the second wavelength.” Appx705 (47:17–25); *see also* Appx815 (45:47–55).

expert witness’s testimony tend to show that the disputed limitations have written description support.” Appx420 (citation omitted).²⁵

In more detail, Figures 7A and 7B each show two emitters or LEDs, each labeled 104:

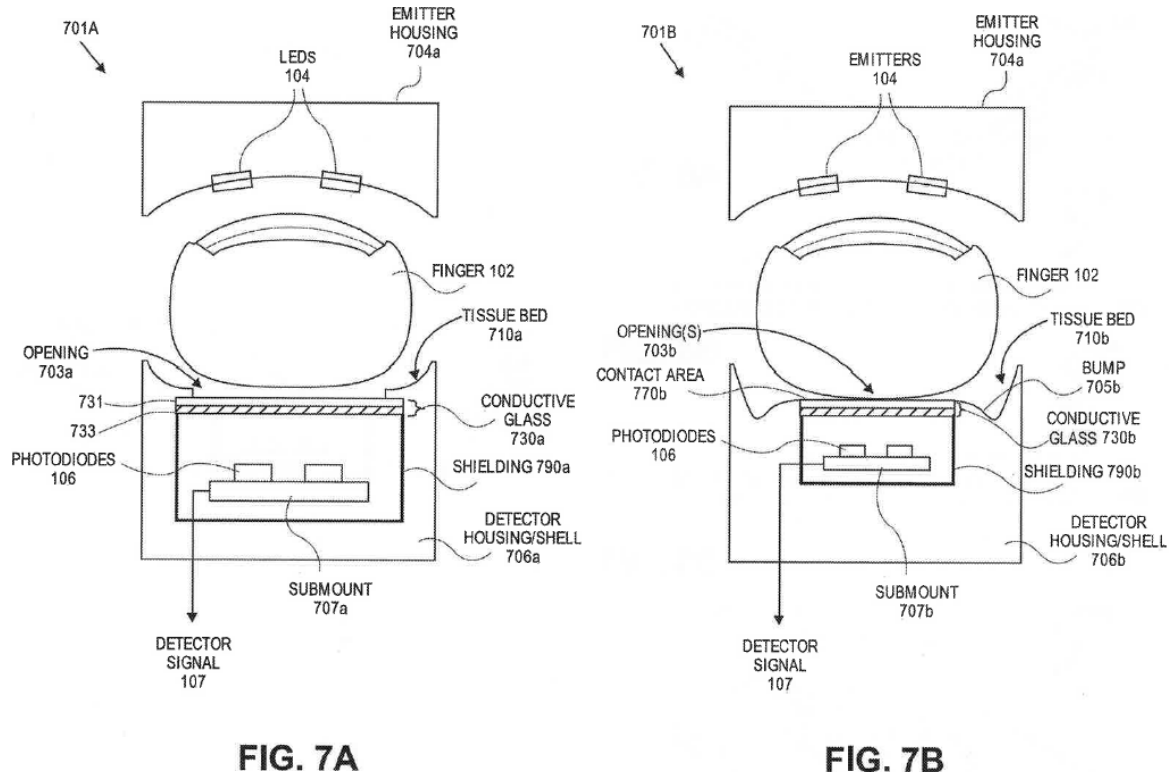

Appx522–523. Within the respective figures, the LEDs/emitters 104 share the same label, suggesting that they are the same. Appx421–422. Furthermore, as discussed above, the specification overwhelmingly teaches using “a plurality of

²⁵ Apple does not dispute that its witness’s testimony was conclusory, that it relied on only attorney argument below, or that Masimo’s witness’s testimony (Appx41446 (1349:15–21)) tended to show that the disputed limitations have written description support.

LEDs” or multiple sets of LEDs as the emitters. *E.g.*, Appx573 (4:55–57). These LEDs can include “sets of optical sources” “capable of emitting visible and near-infrared optical radiation.” Appx422 (citing Appx577 (12:9–12); Appx576 (9:60–63), Appx578 (13:16–21); Appx41446–41447 (1349:7–1350:3)); Appx577 (12:26–32, 12:38–40) (emitting at more than one wavelength). The Commission properly reasoned that, “[i]f the two sets of LEDs or the two emitters having sets of optical sources are the same, then they must emit the same visible and near-infrared optical radiation, *i.e.*, at the same two respective wavelengths,” and that “[a]t a minimum, the specifications do not clearly and convincingly show that these respective wavelengths of visible and near-infrared optical radiation are different between the identically-labelled LEDs or optical emitters.” Appx422.

Additionally, in an undisputed finding, the Commission found that the specification teaches that each emitter 104 includes sets of LEDs that can emit light “at or about 1610 nm, about 1640 nm, *and* about 1665 nm,” Appx577 (12:38–40)²⁶ (emphasis added), and thus each emitter would have an LED with each of those three wavelengths, supporting the disputed limitation. Appx423–424. Thus, substantial evidence supports the Commission’s conclusion that Apple failed to

²⁶ *See also* Appx577–578 (12:64–13:25); Appx586 (29:19–22).

show by clear and convincing evidence that the matching wavelength limitations lack written description support.

Apple alleges that “nothing in the specification states that the emitters 104 must be identical.” Br. 58–59. Yet, the written description standard evaluates whether Masimo had possession of the disputed limitation, not whether the specification states that the emitters *must* be identical. Moreover, this allegation does not undermine the Commission’s factual finding that *Apple failed to show by clear and convincing evidence* that the matching wavelength limitations lacked support. The Commission acknowledged that the evidence was not conclusive, but properly recognized that Apple had the burden of proof, and reasonably found that Apple failed to meet that burden. Appx420–423. Apple further cites the testimony of Joe Kiani that pulse oximetry requires more than one wavelength, Br. 59, which, if anything, seems to support the Commission’s conclusion, and nevertheless does not address the intrinsic evidence. Apple also alleges that Masimo’s expert’s use of different colors in illustrating the emitters 104 in Figure 7B shows a lack of written description. However, that same witness unequivocally and undisputedly testified that the claim limitation has written description support, (Appx41446 (1349:15–21)), and different colors were used to show two emitters 104.

VII. THE COMMISSION PROPERLY CONSTRUED THE CLAIMS AND FOUND THAT APPLE WATCHES INFRINGE THE ASSERTED CLAIMS²⁷

A. The Commission Properly Construed the “Over”/“Above” Claim Terms, a Construction Under Which the Accused Apple Watches Indisputably Infringe.

The Commission properly construed the “over”/“above” terms of claims 22 and 28 of the ’502 patent and claims 24 and 30 of the ’648 patent,²⁸ fully resolving the claim construction dispute. Specifically, the Commission rejected Apple’s argument that the disputed terms require that the claimed structures be arranged vertically when the claimed device is in use (*i.e.*, in relation to the Earth), instead finding the disputed terms refer to the relative positional relationships of the claimed structures. Appx31–35; *Vivid Techs., Inc. v. Am. Sci. & Eng’g, Inc.*, 200 F.3d 795, 803 (Fed. Cir. 1999) (claim terms only need to be construed “to the extent necessary to resolve the controversy”).

The Commission first made the undisputed conclusion that “over” and “above” are “commonly understood words with ordinary meanings that can be understood by a lay judge.” Appx34 (citing *Phillips v. AWH Corp.*, 415 F.3d

²⁷ Here, infringement rises or falls with claim construction.

²⁸ The claims recite, for example, “each opening positioned over a different one ... of the four photodiodes.” Appx704 (46:33–35); *see also* Appx705 (47:31) (“above”); Appx815 (46:44) (“over”).

1303, 1314 (Fed. Cir. 2005)). The Commission next found that, in the context of the field of wearable medical equipment, “over” is commonly used “to describe an arrangement where one feature covers another,” Appx34, such as how a bandage may be “over” a wound on a hand, “irrespective of the orientation” of the hand. Appx40796 (701:12–18). In another undisputed finding, the Commission found that the specification “does not require any specific orientation of the device,” a conclusion indisputably consistent with the use of “above” in Apple’s relied-upon prior art and expert witness testimony. Appx34 (n.4) (adopting Masimo’s arguments at Appx22294–22300 and Appx21833–21834). For example, the specification includes an example of a material described as “over” a glass layer when that material is depicted as being below the glass layer. Appx585 (27:59–62); Appx522. The Commission further found that Masimo’s view of the claims is consistent with the usage of the disputed claim terms in the asserted claims. Appx34–35. Thus, the Commission properly rejected Apple’s proposed claim construction, finding instead that the “claim language does not restrict the orientation of these features, and whether the claimed photodiodes are facing upward or downward in relation to the Earth does not affect a device’s satisfaction of this limitation.” Appx34–35.

Apple asserts as undisputed that “every embodiment in the shared specification” shows the protrusion positioned spatially “on top of or higher than

the photodiodes.” Br. 61. Apple’s assertion is both disputed and incorrect. *E.g.*, Appx22296 (the Asserted Patents describe “small, wearable devices whose orientations are not fixed”); Appx32 (noting the same); Appx509–511 (Figures 2B–2D, illustrating a device having a sensor 201 (comprising the claimed protrusion and photodiodes) with the protrusion *either* on top or on bottom of the photodiodes with respect to the Earth by virtue of the flexible cable 212). Furthermore, instead of pointing to evidence or legal authority that would support its construction, Apple incorrectly alleges that the Commission relied only on Masimo’s expert and the Commission’s “personal views” regarding the common usage of “over.” Br. 61. However, the witness’s testimony explained that Masimo’s construction was “how one of ordinary skill ... would understand” the use of “over,” Appx40796 (701:12–18), and the Commission found that the specification “does not require any specific orientation of the device.” Appx34 (n.4). In another argument not raised below, Apple asserts that Masimo’s bandage analogy is “strained” because “over”/“above” are claimed in reference to “openings”/“holes,” which are allegedly the “absence of material.” Br. 61 (emphasis omitted). However, the claims use “over”/“above” in relation to, for

example, photodiodes,²⁹ and as discussed next, the Commission properly construed the “openings”/“through holes” terms as not being limited to the absence of material, allowing for transparent material therein.

B. The Commission Properly Construed the “Openings”/“Through Holes” Terms, a Construction Under Which the Accused Apple Watches Indisputably Infringe.

The Commission properly construed the “openings”/“through holes” terms of all claims subject to appeal, concluding that, in the context of the patents, the terms do not preclude transparent material placed therein.³⁰ Appx35–38. In doing so, the Commission first recognized, by way of analogy, that “a skylight would still be an ‘opening’ in a roof after a glass window is installed, and a swimming hole is still a ‘hole’ when it is filled with water.” Appx36. The Commission then, after carefully reviewing the claims and specifications, found that these analogies hold true in the context of the patents. Appx36–38 (citing, *inter alia*, Appx704 (46:38) (’502 patent, claim 19, reciting an “optically transparent material within each of the openings”); Appx815 (46:43–44) (’648 patent, claim 20, reciting “each through hole including a window”); Appx575 (8:26–30) (“The openings can be

²⁹ Appx815 (46:43–45) (“[E]ach through hole ... arranged over a different one of the ... photodiodes.”).

³⁰ The claims recite, for example, “each opening positioned over a different one ... of the four photodiodes.” Appx704 (46:33–35); *see also* Appx705 (47:34); Appx815 (46:42–43).

made from glass to allow attenuated light from a measurement site, such as a finger, to pass through to one or more detectors.”)). The Commission additionally relied upon expert witness testimony supporting the above. Appx37; Appx40797–40798 (702:8–703:10). The Commission’s construction is consistent with the purpose of the openings/though holes being to allow light to pass through to the detectors, a purpose not undermined by the inclusion of transparent material. Appx575 (8:26–30).

On appeal, Apple alleges no error in the Commission’s findings and conclusions regarding the intrinsic evidence. Instead, Apple cites only a general-purpose dictionary (not presented to the Commission), and attacks only the Commission’s skylight analogy (and here based only on its unsupported view of what an ordinary English speaker would say). Br. 62–63. In doing so, Apple addresses neither the Commission’s swimming hole analogy (because it disproves Apple’s argument) nor the Commission’s proper analysis of and findings regarding the intrinsic evidence (which accounts for the word “through” at least because an opening made of “glass” is an optically transparent material from one side to the other). *Id.* Accordingly, the Commission should be affirmed.

VIII. THE COMMISSION PROPERLY EXERCISED ITS DISCRETION IN REJECTING APPLE’S WAIVED LACHES ARGUMENT

To show that the Asserted Patents were unenforceable for prosecution laches, Apple had to show that (1) Masimo’s alleged prosecution delay was

unreasonable and inexcusable under the totality of circumstances, and (2) Apple was prejudiced by that delay. *See Cancer Rsch. Tech. Ltd. v. Barr Labs., Inc.*, 625 F.3d 724, 728–29 (Fed. Cir. 2010).

A. Apple Waived Its Argument.

Apple’s prosecution laches argument is waived for not being properly presented in its petition for Commission review. *See supra* Argument Part II; Appx23713–23714. Apple’s single-paragraph allegation of error in its petition did not provide the Commission any real opportunity for correction of any alleged error and did not provide Masimo any real opportunity to respond.³¹ *See supra* Argument Part II. Apple failed to cite the ALJ’s decision (let alone a specific finding or conclusion) or the evidentiary record. Further, in violation of the Commission’s rules, Apple incorporated six pages of argument from its earlier briefing, causing Apple to exceed the Commission’s page count limitations for

³¹ Apple declared only:

For the reasons discussed in Apple’s initial post-hearing brief [Appx22786–22787] and consistent with Federal Circuit precedent regarding, as recently confirmed in [*Personalized Media Comm’ns, LLC v. Apple Inc.*, 57 F.4th 1346 (Fed. Cir. 2023)], the ID erred in its finding that Apple had not shown the asserted Poeze patents unenforceable under the doctrine of prosecution laches and/or unclean hands. Complainants’ twelve-year delay in filing the applications for the asserted Poeze patents was both unreasonable and prejudicial to Apple.

Appx23713–23714.

petitions. 19 C.F.R. § 210.43(b); Appx23713–23714. Apple’s “argument” was not sufficiently raised in its petition and was therefore rightfully disregarded under the Commission’s rules and this Court’s precedent.

B. Apple Failed to Show an Unreasonable and Inexcusable Delay.

In any event, the Commission did not abuse its discretion in finding that Apple failed to show an unreasonable and inexcusable delay. Appx175–179. Before the ALJ, Apple alleged that Masimo engaged in gamesmanship by filing new applications in response to Apple’s successive releases of its Apple Watch models, pointing particularly to a five-year gap in new application filings between 2010 and 2015 and a twelve-year gap between the priority date and the 2020 filing of the Asserted Patents’ applications. Appx175–176; Appx22787–22789. The Commission properly rejected this argument.

In evaluating Apple’s argument, the Commission first recognized that the prosecution laches analysis requires examining the “prosecution history”; prosecution laches should only be applied in “egregious cases of misuse” of the patent system; and that there are “legitimate grounds for refiling a patent application.” Appx178 (quoting *Symbol Techs., Inc. v. Lemelson Med., Educ., & Rsch. Found*, 422 F.3d 1378, 1385, 1386 (Fed. Cir. 2005)). Apple disputes none of these points.

Next, the Commission evaluated the totality of the evidence. Appx177–178. Regarding the alleged 2010–2015 gap, the Commission recognized the undisputed continuous prosecution of several applications in the same family during that time. Appx177–178. The Commission further found that the application following the 2015 application was a divisional application filed because of a restriction requirement, an explicitly recognized “legitimate reason for refiling a patent application.” Appx178 (quoting *Symbol Techs.*, 422 F.3d at 1385). Then, in an overall assessment of the entire prosecution history, and consistent with the testimony of a former USPTO Commissioner for Patents, the Commission found that Apple failed to show that any application in the Asserted Patents’ family was filed merely for delay purposes. Appx178; Appx22435; Appx41506–41507 (1409:9–1410:5); Appx41510–41512 (1413:10–1415:10). The Commission additionally found that Apple failed to show that any newly-asserted claim limitation was specifically drawn to Apple’s products, as would be expected if Masimo engaged in a pattern of drafting claims only after reviewing Apple’s products. Appx179 (n.65). Thus, the Commission properly found that, contrary to Apple’s allegations that Masimo tied its application filings to Apple Watch releases, Masimo’s prosecution appeared to be legitimate continuing prosecution. Appx178.

On appeal, for the first time, Apple asserts that the Commission improperly “placed heavy weight on the fact that this Court has not previously found laches on a similar set of facts.” Br. 65. However, as discussed above, the Commission considered the totality of the evidence. Appx177–178. Second, Apple argues that “Masimo’s conduct resembles that of patentees in previous cases finding laches.” Br. 65. However, of the cited cases, only *In re Bogese* is a precedential decision affirming a laches finding, and it did so on vastly different facts. *In re Bogese*, 303 F.3d 1362, 1366–68 (Fed. Cir. 2002) (USPTO did not abuse discretion in finding laches where patentee engaged in a pattern of filing applications without amended claims and abandoning applications instead of addressing rejections).³² Third, Apple asserts that the Commission found that the “mere fact” that there was continuous prosecution activity weighed against laches. Br. 66. However, again,

³² Apple also cites *Hyatt*, 998 F.3d at 1347, where the Court remanded to the district court, and *Hynix Semiconductor Inc. v. Rambus Inc.*, 2007 WL 4209386 (N.D. Cal. Nov. 26, 2007), which merely denied the patentee’s motion for a summary judgment against the defendants’ laches defense. Apple also cites *Sonos, Inc. v. Google LLC*, 2023 WL 6542320 (N.D. Cal. Oct. 6, 2023), which is pending appeal, No. 24-1097 (Fed. Cir.). But the facts there are also markedly different at least because the patentee repeatedly delayed the issuance of allowed claims, *id.* at *26 n.11, added new matter while hiding that fact from the Patent Office and the district court, *id.* at *24–25, and added that new matter after meeting with the defendant and seeing the defendant’s confidential product plans, *id.* at *11.

the Commission considered the totality of the circumstances. Accordingly, the Commission did not abuse its discretion.

CONCLUSION

For the above reasons, the Commission respectfully requests affirmance of its final determination.

Respectfully submitted,

/s/ Ronald A. Traud

DOMINIC L. BIANCHI

General Counsel

WAYNE W. HERRINGTON

Assistant General Counsel

RONALD A. TRAUD

Attorney Advisor

Office of the General Counsel

U.S. International Trade Commission

500 E Street, SW

Washington, DC 20436

(202) 205-3427

Date: June 28, 2024

CERTIFICATE OF SERVICE

I, Ronald A. Traud, hereby certify on this 28th day of June 2024 that I filed the attached **CONFIDENTIAL BRIEF OF APPELLEE INTERNATIONAL TRADE COMMISSION** using this Court's CM/ECF system. Service to principal counsel of record, per the written consent of the parties, will be accomplished electronically by a secured electronic file transfer system on this same date.

/s/ Ronald A. Traud

Ronald A. Traud
Attorney for Appellee
U.S. International Trade Commission
500 E Street, SW
Washington, DC 20436
Telephone: (202) 205-3427
Fax: (202) 205-3111
Ronald.Traud@usitc.gov

**CERTIFICATE OF COMPLIANCE WITH TYPE-VOLUME
LIMITATION, TYPEFACE, AND TYPE STYLE REQUIREMENTS**

Pursuant to Federal Rule of Appellate Procedure 32(g)(1) and Federal Circuit Rule 32(b)(3), I hereby certify that the attached brief complies with the type-volume limitation and typeface requirements of Federal Rules of Appellate Procedure 32(a)(7) and Federal Circuit Rules 32(b)(1) and 32(b)(2). The brief has been prepared in a proportionally-spaced typeface using Microsoft Office 365 ProPlus, in Times New Roman 14-point font. This brief contains a total of 13,944 words based on the word-count function of the word-processing system.

/s/ Ronald A. Traud

Ronald A. Traud

Date: June 28, 2024

**CERTIFICATE OF COMPLIANCE OF BRIEF
CONTAINING MATERIAL SUBJECT TO PROTECTIVE ORDER**

This brief complies with the limitations on confidential material as set forth in Fed. Cir. R. 25.1(d)(1) and 28(d). It contains 4 words marked as confidential, not including those words marked as confidential in Apple's opening brief.

/s/ Ronald A. Traud

Ronald A. Traud

Date: June 28, 2024