

No. 2024-1285

---

---

IN THE  
**United States Court of Appeals**  
FOR THE FEDERAL CIRCUIT

---

APPLE INC.,

*Appellant,*

v.

INTERNATIONAL TRADE COMMISSION,

*Appellee,*

MASIMO CORPORATION, CERCACOR LABORATORIES, INC.,

*Intervenors.*

---

Appeal from the United States International Trade Commission  
in Investigation No. 337-TA-1276

---

**CORRECTED NONCONFIDENTIAL BRIEF OF INTERVENORS  
MASIMO CORPORATION AND CERCACOR LABORATORIES, INC.**

---

Jonathan E. Bachand

**KNOBBE, MARTENS, OLSON & BEAR, LLP**

1717 Pennsylvania Avenue N.W.

Suite 900

Washington, DC 20006

(202) 640-6400

Joseph R. Re

*Principal Counsel*

Stephen C. Jensen

Sheila N. Swaroop

Brian C. Claassen

**KNOBBE, MARTENS, OLSON & BEAR, LLP**

2040 Main Street, 14<sup>th</sup> Floor

Irvine, CA 92614

(949) 760-0404

*Counsel for Intervenors*

*Masimo Corporation and*

*Cercacor Laboratories, Inc.*

---

July 10, 2024

**PATENT CLAIMS AT ISSUE**

**U.S. Patent No. 10,912,502 (dependent claim 22, independent claim 28)**

19. A user-worn device configured to non-invasively measure an oxygen saturation of a user, the user-worn device comprising:

a plurality of emitters configured to emit light, each of the emitters comprising at least two light emitting diodes (LEDs);

four photodiodes arranged within the user-worn device and configured to receive light after at least a portion of the light has been attenuated by tissue of the user;

a protrusion comprising a convex surface including separate openings extending through the protrusion and lined with opaque material, each opening positioned over a different one of the four photodiodes, the opaque material configured to reduce an amount of light reaching the photodiodes without being attenuated by the tissue;

optically transparent material within each of the openings; and one or more processors configured to receive one or more signals

from at least one of the four photodiodes and output measurements responsive to the one or more signals, the measurements indicative of the oxygen saturation of the user.

20. The user-worn device of claim 19 further comprising a thermistor.

21. The user-worn device of claim 20, wherein the one or more processors are further configured to receive a temperature signal from the thermistor and adjust operation of the user-worn device responsive to the temperature signal.

22. The user-worn device of claim 21, wherein the plurality of emitters comprise at least four emitters, and wherein each of the plurality of emitters comprises a respective set of at least three LEDs.

28. A user-worn device configured to non-invasively measure an oxygen saturation of a user, the user-worn device comprising:

a first set of light emitting diodes (LEDs), the first set of LEDs comprising at least an LED configured to emit light at a first wavelength and an LED configured to emit light at a second wavelength;

a second set of LEDs spaced apart from the first set of LEDs, the second set of LEDs comprising at least an LED configured to emit light at the first wavelength and an LED configured to emit light at the second wavelength;

four photodiodes arranged in a quadrant configuration on an interior surface of the user-worn device and configured to receive light after at least a portion of the light has been attenuated by tissue of the user;

a thermistor configured to provide a temperature signal;

a protrusion arranged above the interior surface, the protrusion comprising:

a convex surface;

a plurality of openings in the convex surface, extending through the protrusion, and aligned with the four photodiodes, each opening defined by an opaque surface configured to reduce light piping; and

a plurality of transmissive windows, each of the transmissive windows extending across a different one of the openings;

at least one opaque wall extending between the interior surface and the protrusion, wherein at least the interior surface, the opaque wall and the protrusion form cavities, wherein the photodiodes are arranged on the interior surface within the cavities;

one or more processors configured to receive one or more signals from at least one of the photodiodes and calculate an oxygen saturation measurement of the user, the one or more processors further configured to receive the temperature signal;

a network interface configured to wirelessly communicate the oxygen saturation measurement to at least one of a mobile phone or an electronic network;

a user interface comprising a touch-screen display, wherein the user interface is configured to display indicia responsive to the oxygen saturation measurement of the user;

a storage device configured to at least temporarily store at least the measurement; and

a strap configured to position the user-worn device on the user.

**U.S. Patent No. 10,945,648 (dependent claims 12, 24 and 30)**

8. A user-worn device configured to non-invasively determine measurements of a physiological parameter of a user, the user-worn device comprising:

a first set of light emitting diodes (LEDs), the first set comprising at least an LED configured to emit light at a first wavelength and at least an LED configured to emit light at a second wavelength;

a second set of LEDs spaced apart from the first set of LEDs, the second set of LEDs comprising an LED configured to emit light at the first wavelength and an LED configured to emit light at the second wavelength;

four photodiodes;

a protrusion comprising a convex surface, at least a portion of the protrusion comprising an opaque material;

a plurality of openings provided through the protrusion and the convex surface, the openings aligned with the photodiodes;

a separate optically transparent window extending across each of the openings; one or more processors configured to receive one or more signals from at least one of the photodiodes and output measurements of a physiological parameter of a user;

a housing; and

a strap configured to position the housing proximate tissue of the user when the device is worn.

12. The user-worn device of claim 8, wherein the physiological parameter comprises oxygen or oxygen saturation.

20. A user-worn device configured to non-invasively determine measurements of a user's tissue, the user-worn device comprising:

a plurality of light emitting diodes (LEDs);

at least four photodiodes configured to receive light emitted by the LEDs, the four photodiodes being arranged to capture light at different quadrants of tissue of a user;

a protrusion comprising a convex surface and a plurality of through holes, each through hole including a window and arranged over a different one of the at least four photodiodes; and

one or more processors configured to receive one or more signals from at least one of the photodiodes and determine measurements of oxygen saturation of the user.

24. The user-worn device of claim 20, wherein the protrusion comprises opaque material configured to substantially prevent light- piping.

30. The user-worn device of claim 20, wherein the protrusion further comprises one or more chamfered edges.

**CERTIFICATE OF INTEREST**

Counsel for Intervenors Masimo Corporation and Cercacor Laboratories, Inc.

certifies the following:

1. The full name of the parties represented by me is:

Masimo Corporation  
52 Discovery  
Irvine, CA 92618  
Telephone: 949-297-7000

Cercacor Laboratories, Inc.  
15750 Alton Pkwy  
Irvine, CA 92618  
Telephone: 800-610-8522

2. The name of the real party in interest represented by me is:

N/A

3. Full name of all parent corporations and all publicly held companies that own 10 percent or more of the stock of the party represented by me are:

Masimo Corporation has no parent corporation. BlackRock, Inc. owns at least 10% of Masimo Corporation's stock.

Cercacor Laboratories, Inc. has no parent corporation and no publicly held company owns at least 10% of Cercacor Laboratories, Inc's stock.

4. Other than those who have already made an appearance in this Appeal, the name of all law firms, partners, and associates that (a) appeared for the entities in the originating court or agency or (b) are expected to appear in this Court are:

Knobbe, Martens, Olson & Bear, LLP: Ted M. Cannon, Brian C. Claassen, Irfan A. Lateef, Alan G. Laquer, Kendall M. Loebbaka, Carol Pitzel Cruz, Douglas B. Wentzel, Daniel C. Kiang, William R. Zimmerman, Karl W. Kowallis, and Matthew S. Friedrichs.

5. The title and number of any case known to counsel to be pending in this or any other court or agency that will directly affect or be directly affected by this court's decision in the pending appeal are as follows:

*Apple Inc. v. Masimo Corp.*, 1:22-cv-01378 (D. Del).

6. Information required under Fed. R. App. P. 26.1(b) (organizational victims in criminal cases) and 26.1(c) (bankruptcy case debtors and trustees):

None.

KNOBBE, MARTENS, OLSON & BEAR, LLP

Dated: June 28, 2024

By: /s/ Joseph R. Re

Joseph R. Re

*Counsel for Intervenors  
Masimo Corporation and  
Cercacor Laboratories, Inc.*

## TABLE OF CONTENTS

	<b>Page No.</b>
PATENT CLAIMS AT ISSUE	
CERTIFICATE OF INTEREST .....	i
TABLE OF AUTHORITIES .....	vii
STATEMENT OF RELATED CASES .....	xi
I. INTRODUCTION .....	1
II. STATEMENT OF THE ISSUES .....	2
III. STATEMENT OF THE CASE .....	3
A. Masimo Becomes The Pulse Oximetry Industry Leader .....	3
B. Masimo Invests In, And Develops, Masimo Watch .....	4
C. Apple Struggles Implementing Pulse Oximetry In Apple Watch .....	7
D. The Two Patents On Appeal .....	9
E. Prior Proceedings .....	12
1. The ALJ Rejected Apple’s Misreading Of The Complaint .....	12
2. The Evidentiary Hearing .....	13
3. The Final ID .....	13
4. The PTAB Rejects Apple’s IPR Petitions .....	15
5. The Commission’s Review .....	16
IV. SUMMARY OF THE ARGUMENT .....	19
V. ARGUMENT .....	22
A. Standard Of Review .....	22



**TABLE OF CONTENTS**  
**(cont'd)**

	<b>Page No.</b>
B. Substantial Evidence Supports The Commission’s Findings That Masimo Made Patented Articles Before The Complaint .....	24
1. Apple Ignores Masimo’s Development Activities Years Before The Complaint .....	25
2. Apple Dismisses The Abundant Evidence Of Masimo’s Pre-Complaint Patent-Practicing Articles.....	25
3. Substantial Evidence Supports The Commission’s Finding That Masimo Satisfied The Technical Prong.....	27
4. Apple’s Challenge Of The Commission’s Domestic Industry Analysis Is Without Merit .....	28
a. Apple’s Argument That The Commission Relied On A “Hypothetical Article” Ignores The Evidence And The Commission’s Holding.....	29
b. The Commission Is Free To Rely On Circumstantial Evidence.....	32
c. Apple Cannot Dismiss The Evidence Supporting The Commission’s Technical Prong Findings.....	34
C. Substantial Evidence Supports The Commission’s Finding That Masimo Satisfied The Economic Prong .....	36
1. Apple Fails To Show Error In The Commission’s Holding That Masimo Employed Significant Labor On Masimo Watch .....	37
2. The Commission Properly Relied On Substantial Evidence Quantifying Masimo’s Domestic Employment .....	40

**TABLE OF CONTENTS**  
*(cont'd)*

	<b>Page No.</b>
3. Apple’s Policy Arguments Are Baseless .....	41
D. Substantial Evidence Supports The Commission Findings Underlying Its Rejection Of Apple’s Obviousness Defense.....	42
1. Apple Cannot Show Any Error In The Commission Examining Whether A POSITA Could Modify Lumidigm To Measure Blood Oxygen At The Wrist.....	43
2. Abundant Evidence Supports The Commission’s Finding That A POSITA Would Not Have Had A Reasonable Expectation Of Success In Modifying Lumidigm To Measure Blood Oxygen At All.....	46
3. Substantial Evidence Supports The Commission’s Finding That Lumidigm Does Not Teach Or Suggest The Claimed “Transmissive Windows” Or “Optically Transparent Material” .....	49
E. Substantial Evidence Supports The Commission’s Findings Rejecting Apple’s Written Description Defenses .....	53
1. The Poeze Patents’ Specification Expressly Links The Multiple LEDs, Four Photodiodes, Protrusions With “Openings” Or “Holes,” And Opaque Materials .....	54
2. The Specification Discloses Emitters Each With An Identical Set Of LEDs.....	57
F. The Commission Correctly Construed The Claims To Find Infringement Of Every Asserted Poeze Patent Claim.....	60
1. The Commission Correctly Construed “Over”/“Above” To Find Infringement Of Every Asserted Poeze Patent Claim .....	60

**TABLE OF CONTENTS**  
*(cont'd)*

	<b>Page No.</b>
2. The ID Correctly Construed “Through Holes” And “Openings” Through The Protrusion To Find Infringement Of Every Asserted Poeze Patent Claim .....	62
G. The Commission Did Not Abuse Its Discretion In Rejecting Apple’s Prosecution Laches Defense .....	63
1. Apple Waived Its Prosecution Laches Defense.....	63
2. Apple Cannot Show The Commission Abused Its Discretion In Rejecting Apple’s Prosecution Laches Defense .....	65
VI. CONCLUSION.....	69

**Rule 25.1(e)(1)(B) Statement:** The material omitted on page 5 are images of Cercacor’s confidential product development for wrist-worn technology. The material omitted on page 26 are images of Masimo’s confidential product development for the Masimo W1 Watch. The material omitted on pages 6-7, 21, 36, and 40-41 contains confidential, competitively sensitive economic information regarding the Masimo W1 watch. Masimo designated this information as Confidential Business Information under the Administrative Protective Order in effect in ITC Investigation No. 1276. The material omitted on pages 8, 48, and 61 contains information that Appellant Apple Inc. designated as Confidential Business Information under the Administrative Protective Order in effect in ITC Investigation No. 1276.

**TABLE OF AUTHORITIES**

**Page No(s).**

**CASES**

*Adidas AG v. Nike, Inc.*,  
963 F.3d 1355 (Fed. Cir. 2020) .....52

*Alloc, Inc. v. Int’l Trade Comm’n*,  
342 F.3d 1361 (Fed. Cir. 2003) .....22

*Broadcom Corp. v. Int’l Trade Comm’n*,  
542 F.3d 894 (Fed. Cir. 2008) .....24, 55

*Broadcom Corp. v. Int’l Trade Comm’n*,  
28 F.4th 240 (Fed. Cir. 2022) .....23

*Cancer Rsch. Tech. Ltd. v. Barr Lab’ys, Inc.*,  
625 F.3d 724 (Fed. Cir. 2010) ..... 65-66

*Centocor Ortho Biotech, Inc. v. Abbott Lab’ys*,  
636 F.3d 1341 (Fed. Cir. 2011) .....53

*Certain Active Matrix Organic Light-Emitting Diode Display Panels  
and Modules for Mobile Devices*, Inv. No. 337-TA-1351, EDIS  
Doc. ID. 821542, Comm’n Op. (May 15, 2024) .....31 n.6

*Certain Electronic Stud Finders*,  
Inv. No. 337-TA-1221, 2022 WL 834280 (ITC Mar. 14, 2022).....38

*Certain Raised Garden Beds*,  
Inv. No. 337-TA-1334, EDIS Doc. ID. 817237, Comm’n Op.  
(Apr. 1, 2024).....41

*Certain Solid State Storage Drives*,  
Inv. No. 337-TA-1097, EDIS Doc. ID. 649139, Comm’n Op.  
(June 29, 2018) .....41

*Finnigan Corp. v. Int’l Trade Comm’n*,  
180 F.3d 1354 (Fed. Cir. 1999) .....24, 65

*Flash-Control, LLC v. Intel Corp.*,  
2021 WL 2944592 (Fed. Cir. July 14, 2021)..... 56-57

**TABLE OF AUTHORITIES**  
*(cont'd)*

	<b>Page No(s).</b>
<i>Guangdong Alison Hi-Tech Co. v. Int’l Trade Comm’n</i> , 936 F.3d 1353 (Fed. Cir. 2019) .....	65
<i>Hyatt v. Hirshfeld</i> , 998 F.3d 1347 (Fed. Cir. 2021) .....	68
<i>Hybritech Inc. v. Monoclonal Antibodies, Inc.</i> , 802 F.2d 1367 (Fed. Cir. 1986) .....	59
<i>Hynix Semiconductor Inc. v. Rambus Inc.</i> , 2007 WL 4209386 (N.D. Cal. Nov. 26, 2007) .....	68-69
<i>In re Bogese</i> , 303 F.3d 1362 (Fed. Cir. 2002) .....	68
<i>In re Epstein</i> , 32 F.3d 1559 (Fed. Cir. 1994) .....	45
<i>In re Paulsen</i> , 30 F.3d 1475 (Fed. Cir. 1994) .....	45
<i>Koito Mfg. Co. v. Turn-Key-Tech, LLC</i> , 381 F.3d 1142 (Fed. Cir. 2004) .....	54
<i>KSR Int’l Co. v. Teleflex Inc.</i> , 550 U.S. 398 (2007).....	52
<i>Michalic v. Cleveland Tankers, Inc.</i> , 364 U.S. 325 (1960) .....	33
<i>Microsoft Corp. v. Int’l Trade Comm’n</i> , 731 F.3d 1354 (Fed. Cir. 2013) .....	37-38
<i>Moleculon Research Corp. v. CBS, Inc.</i> , 793 F.2d 1261 (Fed. Cir. 1986) .....	33
<i>Motiva, LLC v. Int’l Trade Comm’n</i> , 716 F.3d 596 (Fed. Cir. 2013) .....	23

**TABLE OF AUTHORITIES**  
*(cont'd)*

	<b>Page No(s).</b>
<i>Novozymes A/S v. Dupont Nutrition Biosciences APS</i> , 723 F.3d 1336 (Fed. Cir. 2013) .....	56
<i>Orion IP, LLC v. Hyundai Motor Am.</i> , 605 F.3d 967 (Fed. Cir. 2010) .....	42
<i>Personalized Media Commc'ns, LLC v. Apple Inc.</i> , 57 F.4th 1346 (Fed. Cir. 2023) .....	69
<i>Philip Morris Prods. S.A. v. Int'l Trade Comm'n</i> , 63 F.4th 1328 (Fed. Cir. 2023) .....	23, 64
<i>Purdue Pharma L.P. v. Faulding Inc.</i> , 230 F.3d 1320 (Fed. Cir. 2000) .....	58
<i>Raytheon Techs. Corp. v. Gen. Elec. Co.</i> , 993 F.3d 1374 (Fed. Cir. 2021) .....	23, 44, 45
<i>Sonos, Inv. v. Google LLC</i> , 2023 WL 6542320 (N.D. Cal. Oct. 6, 2023) .....	67
<i>Spansion, Inc. v. Int'l Trade Comm'n</i> , 629 F.3d 1331 (Fed. Cir. 2010) .....	22
<i>Symbol Techs., Inc. v. Lemelson Med., Educ. &amp; Rsch. Found.</i> , 422 F.3d 1378 (Fed. Cir. 2005) .....	68
<i>Transocean Offshore Deepwater Drilling, Inc. v. Maersk Drilling USA, Inc.</i> , 699 F.3d 1340 (Fed. Cir. 2012) .....	45
<i>WBIP, LLC v. Kohler Co.</i> , 829 F.3d 1317 (Fed. Cir. 2016) .....	54
<i>Winbond Elecs. Corp. v. Int'l Trade Comm'n</i> , 262 F.3d 1363 (Fed. Cir. 2001) .....	24
<i>Zircon Corp. v. Int'l Trade Comm'n</i> , 101 F.4th 817 (Fed. Cir. 2024) .....	38, 41

**TABLE OF AUTHORITIES**  
*(cont'd)*

**Page No(s).**

**STATUTES**

5 U.S.C. § 706.....	22
19 U.S.C. § 1337.....	<i>passim</i>
35 U.S.C. § 112.....	23

**OTHER AUTHORITIES**

19 C.F.R. § 210.12.....	31 n.7
19 C.F.R. § 210.38.....	30
19 C.F.R. § 210.43.....	24, 64
19 C.F.R. § 210.45.....	30
37 C.F.R. § 1.84.....	58

## STATEMENT OF RELATED CASES

No other appeal was ever filed in this or any other appellate court from Investigation No. 337-TA-1276 (the “Investigation”). This Court’s decision in this appeal may affect *Apple Inc. v. Masimo Corp.*, No. 1:22-cv-01378 (D. Del.).



## I. INTRODUCTION

Masimo is an American success story and the world leader in pulse oximetry. Masimo properly invoked the power of the International Trade Commission against an infringing importer—Apple. The Commission found Apple violated 19 U.S.C. § 1337 (“Section 337”) by importing foreign-made Apple Watches with a blood oxygen feature that infringes two Masimo patents. The Commission properly excluded those infringing Apple Watches, finding the public interest supports exclusion.

Apple argues that its scattershot appeal raises significant legal and policy issues. It does not. The investigation involved a routine and thorough application of Section 337 to exclude infringing articles. Five of the six issues Apple challenges merely address whether substantial evidence supports the Commission’s findings of fact. The one legal issue involves claim construction of ordinary words.

Apple attempts to create legal issues by distorting the record and many of the Commission’s findings to argue the Commission exceeded its statutory authority under Section 337. But the Commission did not open its doors to any complainant regardless of whether it can establish a domestic industry as Apple and amici argue. Rather, in detailed opinions of over 400 pages, the Commission found as a matter of fact that Masimo established a domestic industry. Abundant evidence supports that finding and the other findings that Apple challenges. Thus, this Court should affirm.

## **II. STATEMENT OF THE ISSUES**

1. Whether substantial evidence supports the Commission's findings that Masimo created articles protected by U.S. Patent Nos. 10,912,502 and 10,945,648 by the time Masimo filed its Complaint in concluding that Masimo satisfied the technical prong of the domestic industry requirement.

2. Whether substantial evidence supports the Commission's findings that Masimo employed significant domestic labor in research and development for its industry relating to its patent-practicing articles in concluding that Masimo satisfied the economic prong of the domestic industry requirement.

3. Whether substantial evidence supports the Commission's findings about a single prior art patent to Lumidigm in concluding that Apple failed to prove that the asserted claims are invalid for obviousness.

4. Whether substantial evidence supports the Commission's findings that Apple failed to prove the asserted claims lack written description support.

5. Whether the Commission erred in construing "over"/"above" and "openings"/"through holes," constructions under which Apple indisputably infringes.

6. Whether the Commission abused its discretion in rejecting Apple's prosecution laches defense.

### **III. STATEMENT OF THE CASE**

Much of Apple’s Introduction and Statement of the Case has no relevance to any issue on appeal. Apple presses its public-interest talking points, such as how the ban of a “flagship” product harms the public interest, Br. 4-5, and how removal of the blood oxygen feature has “jeopardized health studies that rely on that feature.” Br. 19; *see also* Br. 11-13, 16. But Apple has not appealed the Commission’s public-interest findings. Apple’s Introduction and Statement of the Case appear to be written for the press—not this Court. As for anything relevant, Apple repeatedly misrepresents the record and the Commission’s findings.

#### **A. Masimo Becomes The Pulse Oximetry Industry Leader**

Named inventor Joe Kiani founded Masimo in his California garage in 1989. Appx40172-40173(79:25-80:2). Masimo’s goal was to solve pulse-oximetry problems that the industry thought were unsolvable. Pulse oximetry noninvasively measures arterial oxygen saturation (blood oxygen) by shining two wavelengths of light through a person’s tissue and analyzing the detected light. Appx40173 (80:14-19). The pulse-oximetry industry could not solve the frequent false readings and false alarms caused when patients move or have weak circulation. Appx40178(85:7-13); *see* Appx40173-40178. Masimo solved those problems by the early 1990s, and in 1995, began introducing its technology for use in pulse

oximeters. Appx40177-40178(84:24-85:6). Studies have shown the clinical superiority of Masimo's technology. Appx40179-40181(86:9-88:2).

Masimo now manufactures and sells pulse oximeters used to monitor over 200 million patients a year. Appx40184-40185(91:23-92:1). Masimo has received numerous awards for its pulse oximetry products, Appx40185, and Masimo's pulse oximetry is the standard in nine of the top ten hospitals in the United States. Appx70760. Masimo started introducing various pulse oximeters for consumers in 2013, starting with a device for use with Apple's iPhone. Appx40195-40197 (102:2-104:4); Appx56014; Appx56071; Appx57410-412.

**B. Masimo Invests In, And Develops, Masimo Watch**

Masimo envisioned developing a wrist-worn pulse oximeter from the early 1990s. Appx40207(114:3-12). In 1998, Masimo created Masimo Laboratories, later renamed Cercacor, to research measuring various blood constituents in addition to blood oxygen, such as hemoglobin and glucose. Appx40186(93:12-20). Masimo and Cercacor, its co-complainant, collaborate and cross license their research. Appx40186-40187(93:21-94:17); Appx57615-57618.

After developing a low-power pulse oximeter, Cercacor began developing a wrist-worn pulse oximeter in 2014, and those efforts have been ongoing. Appx40341-40342(248:24-249:8); Appx40208(115:1-7); Appx40432(338:12-21);

CONFIDENTIAL MATERIAL REDACTED

*see* Appx40207-40210(114:1-117:25). By 2015, Masimo made prototypes of wrist-worn pulse oximeters. Appx40341-40343(248:24–250:2); Appx40422(328:8-16).

By 2016, Cercacor had developed prototype wireless wrist-sensors for use in a watch-style pulse oximeter. Appx40208-40210(115:1-116:9); Appx65034-65035; Appx57320. By 2017, Cercacor had developed additional prototypes of wrist-worn pulse oximeters. Appx40209-40210(116:13-117:11).

MASIMO CONFIDENTIAL BUSINESS INFO



Appx65036-65037.

In 2018, Cercacor accurately measured blood oxygen with a wrist-worn pulse oximeter. Appx40211-40212(118:17-119:3); Appx57403 (“Validate SpO2 through the wrist: Q2 2018–100%”).

CONFIDENTIAL MATERIAL REDACTED

In 2019, Masimo began its formal “Masimo Watch” project.<sup>1</sup> Appx40436(342:16-17). Masimo developed Masimo Watch and its foundational technology entirely in California, Appx40415-40416(321:23-322:5), spending over [REDACTED] on that development as of the July 2021 Complaint. Appx21426-21427 (summarizing [REDACTED] expenditures for Masimo Watch Project, plus [REDACTED] of foundational R&D for wrist-worn technology); Appx65104-65105; Appx40594-40596(500:23-502:1); Appx65321-65322; Appx40598(504:9-25); Appx40629-40631(535:24-537:21). By that time, Masimo had employed [REDACTED] people involved with Masimo Watch R&D. Appx53506(AppxS) (excerpted as Appx71241-71244); Appx40598(504:9-13); Appx40211-40212(118:24-119:12). Masimo spent over [REDACTED] specific to Masimo Watch. Appx53503(AppxM) (excerpted as Appx71236-71240); Appx40591(497:1-20); Appx40654-40655 (560:6-561:1); Appx40586-40587(492:16-493:7); Appx40587-40588(493:8-494:17); Appx53499(AppxB) (excerpted as Appx71228-71231 (over [REDACTED] for “R&D Internal Labor” through Complaint); Appx71223-71227 (source of R&D labor allocation for Masimo Watch project codename “STK”)); Appx53492(AppxC) (excerpted as Appx71232-71233) (over [REDACTED] for Masimo Watch executive labor through Complaint); Appx53497(AppxF) (excerpted as Appx71234-71235) (over

---

<sup>1</sup> Masimo refers to its watch project as “Masimo Watch” similar to Apple referring to its Apple Watch product line collectively as just “Watch.” Br. 2 n.2.

CONFIDENTIAL MATERIAL REDACTED

MASIMO CBI for Masimo Watch recruiting labor through Complaint). Masimo also paid MASIMO CBI to domestic third parties for design work specific to Masimo Watch. Appx53459-53461; Appx40589(495:3-10); Appx53497(AppxF) (excerpted as Appx71234-71235). Masimo also spent money in several other, smaller categories for the Masimo Watch Project. *E.g.*, Appx53499(AppxB) (excerpted as Appx71228-71231) (over MASIMO CBI for Masimo Watch R&D space value). Masimo documented its progress throughout the Masimo Watch project. Appx53107-53151; Appx53070-53095; Appx53236-53248; Appx53927-53941; Appx60184-60212.

Masimo developed various prototypes with its continuous hospital-grade pulse oximetry. Appx40436-40437(342:25-343:7); Appx40487-40488(393:12-394:3); Appx40412(318:15-22). This work culminated in the commercial product W1. Appx40496(402:3-7); Appx65067.

**C. Apple Struggles Implementing Pulse Oximetry In Apple Watch**

Apple began developing a watch-based pulse oximeter before the first Apple Watch. Appx52792-52795(14:21-15:1, 25:10-25:20); Appx52823(177:1-6). Between 2015-2019, Apple introduced six watches, but none of them had a blood oxygen feature. Appx154; *see* Appx4580 ¶ 38. Apple failed to introduce a watch with that feature until its Series 6 in September 2020. Appx70356-70357.

Apple represents that “[f]itting a blood oxygen feature into Watch while adhering to Apple’s meticulous design standards was a technological feat.” Br. 2.

CONFIDENTIAL MATERIAL REDACTED

But Apple ignores that its engineers found measuring oxygen at the wrist very challenging. Appx120-121 (citing Appx41108-41109(1012:12-1013:6) (in 2014, Apple Senior Scientist “did not know if it could be done”)); *see* Appx41094-41095(998:21-999:6) (the wrist is “just an incredibly different beast” than fingers or forehead); Appx53017-53018(166:4-167:5) (“The wrist is one of the most difficult places on the body to do almost every physiological measurement”). In 2015, Apple recognized that APPLE CONFIDENTIAL BUSINESS INFO” for it to measure oxygen at the wrist. Appx51912; Appx41079(983:10-12).

In September 2020, Apple knew its oxygen feature was not ready. Appx60425. Apple targeted a low standard of taking just two readings a day in 90% of users. *Id.* But Apple could not meet even that as the Watch obtained two readings in only 37% of users. *Id.* Nonetheless, Apple released the feature in September 2020 during the COVID-19 pandemic. Appx70356-70357. After that release, Apple received negative feedback about the unreliability of its blood oxygen feature. Appx60432-60434; Appx57596-57614; Appx57659-57664.

Relying on selective public-interest submissions, Apple claims its blood-oxygen feature has been praised. Br. 12-13. Apple ignores the many submissions explaining the poor performance and downright dangers of Apple’s blood oxygen



feature.<sup>2</sup> Apple also touts various health and wellness features of its Watch, such as fall detection, the ECG application, and irregular rhythm notification. Br. 11-12. But those features are unrelated to the blood-oxygen feature and any issue on appeal.

**D. The Two Patents On Appeal**

The two patents on appeal are U.S. Patent Nos. 10,912,502 and 10,945,648, part of the family known as the Poeze Patents.<sup>3</sup> The Poeze Patents derive from an ambitious research project seeking to noninvasively measure signals much harder to detect than oxygen, such as hemoglobin and glucose. Appx40191(98:9-17).

The inventors were surprised how pressure on the measurement site improved the strength of the signal, contrary to conventional wisdom that pressure diminishes the signal. Appx40191-40192(98:23-99:1, 99:8-16). This led them to try a sensor with a protrusion at the measurement site, but that caused other problems, one known as light piping. Appx40192(99:2-7). Light piping occurs when the sensor detects emitted light that has not first passed through tissue. Appx65065; Appx40193-40194(100:14-101:5). The industry did not understand the problems caused by light piping. Appx40194-40195(101:13-102:1).

---

<sup>2</sup> The Commission identified public-interest submissions “discouraging reliance” on Apple’s blood oxygen feature. Appx448 (citing Appx23751; Appx24192-24193; Appx24202-24203; Appx24204-24206; Appx24243-24248; Appx24260-24265; Appx24266-24271; Appx24272-24277; Appx24254-24259).

<sup>3</sup> U.S. Patent No. 10,912,501 is also part of the Poeze Patent family.

The patents use a protrusion to improve the signal and include other features to minimize the effects of light piping. Appx40191-40192(98:9-12, 99:2-7). In the patents, the protrusion is labeled as 305 in Figure 3C. Appx624; *see* Appx40192 (99:19-21).

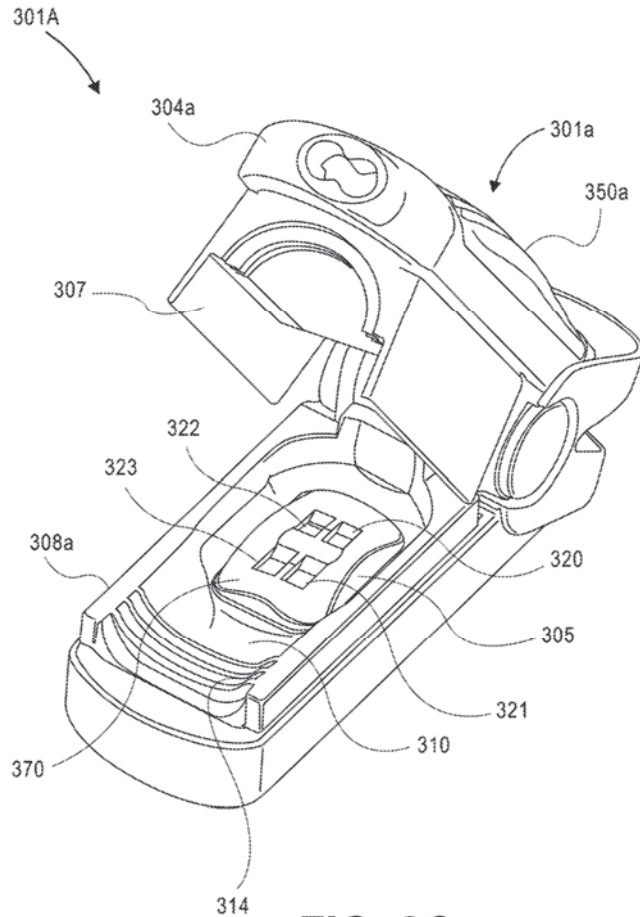

**FIG. 3C**

Four detectors are placed below windows (320, 321, 322, 323) that extend over openings. Appx40192(99:19-24). Each detector is recessed into a hole or well. Each well has walls that extend all the way up to the tissue. Appx40194(101:6-12).

Apple emphasizes that the embodiment in Figure 3C is for a fingertip sensor. Br. 9-10. But Apple ignores that the patents' specification describes using the devices on various measurement sites, including on a person's arm or hand. Appx687(11:45-55).

Apple argues that, six days after Apple launched its Series 6 watch, Masimo "brushed off" a twelve-year-old provisional application of the patents on appeal to obtain claims "manifestly written to ensnare" that watch. Br. 2; *see id.* at 9-10. The Commission rejected Apple's argument in view of Masimo's continuous and proper prosecution activity of the Poeze Patent family throughout the twelve-year period. Appx177-178. The Commission found no evidence supporting Apple's argument. Appx179 n.65.<sup>4</sup>

Apple relies on a footnote from the dissent to support its argument. Br. 2 (citing Appx424-425 n.43), 18 (citing same). But the dissent was from the Commission's rejection of one of Apple's written-description defenses. It did not concern Apple's prosecution laches defense or Apple's argument that Masimo wrote claims to cover Apple's Watch.

---

<sup>4</sup> Except when relevant, this brief refers to the ALJ as the Commission.

**E. Prior Proceedings**

**1. The ALJ Rejected Apple’s Misreading Of The Complaint**

Masimo filed its Complaint in July 2021. Appx6; Appx3739. Apple misreads Masimo’s Complaint and incorrectly argues that it limits the domestic industry issue. Br. 3-4, 13. Apple ignores that the ALJ rejected that misreading weeks before the evidentiary hearing. Appx14136-14138.

In December 2021, Apple filed a motion for terminating sanctions, accusing Masimo of falsely representing its Masimo Watch in the Complaint. Appx6701-6704; Appx6734-6735. The ALJ rejected Apple’s accusations and denied its motion. Appx14128-14141. The ALJ observed that Masimo provided extensive discovery regarding its patent-practicing Masimo Watch articles, including multiple inspections, demonstrations, depositions, and physical samples. *See* Appx14130-14131.

The ALJ ruled that “Apple fails to identify any statement in the Amended Complaint explicitly representing that the ‘Masimo Watch’ was a specified finished product.” Appx14136. The ALJ further held that “Apple has misinterpreted the Amended Complaint to represent that there was a singular ‘Masimo Watch.’” Appx14138. The ALJ also held: “With respect to the ‘Masimo Watch’ samples that were referenced in the Amended Complaint, there is no dispute that multiple

‘Masimo Watch’ physical items existed at the time of the Amended Complaint.” *Id.* Apple never sought Commission review of this Order.

**2. The Evidentiary Hearing**

Apple repeatedly refers to Masimo’s original allegations of infringement of 103 claims across all five patents presented, as if Apple prevailed on most of them. Br. 6, 8, 20, 44-45. Apple ignores that, as the parties prepared for the evidentiary hearing, they substantially narrowed the issues to be presented in view of the five-day time limit. Masimo agreed to present only nine claims from five patents to show infringement, with only five of those claims coming from the two patents on appeal. Appx12242-12244; Appx17262-17264. The Commission never adjudicated the other 90-plus claims. Similarly, Apple abandoned hundreds of prior art combinations and other invalidity and unenforceability defenses.

In June 2022, the ALJ conducted the five-day hearing where the parties presented twenty-two live witnesses, deposition transcripts from seventeen witnesses, and hundreds of exhibits.

**3. The Final ID**

On January 10, 2023, the ALJ issued the 337-page final initial determination (the “FID”), which determined that Apple violated Section 337 by importing infringing Apple Watches. The FID provided detailed findings on all issues except

public interest, which the Commission did not delegate. Below summarizes the FID's findings on appeal.

***Domestic Industry–Technical Prong:*** The ALJ found that several Masimo Watch articles existed at the time of the Complaint and practiced claim 28 of the '502 Patent and claims 12, 24, and 30 of the '648 Patent. Appx60-87. Thus, the ALJ found the technical prong of the domestic industry requirement satisfied for these patents. Appx87-92. The ALJ relied only on pre-Complaint evidence and did not rely on Masimo's W1 Watch. *Id.* The ALJ also found that "the Masimo Watch prototypes are merely 'iterations' of a product design that was continuously developed in the years leading up to the filing of the complaint." Appx308.

***Domestic Industry–Economic Prong:*** The ALJ found Masimo satisfied the economic prong of the domestic industry requirement. Appx306-341. In view of Masimo's significant employment of labor, the ALJ found that a domestic industry relating to articles protected by the patents exists and is also in the process of being established. Appx310-329; Appx341.

***Infringement:*** The ALJ found that the accused Apple Watches infringe claims 22 and 28 of the '502 Patent, and claims 12, 24, and 30 of the '648 Patent. Appx38-60; Appx341.

***Validity:*** The ALJ found that Apple failed to show that any asserted claim of the '502 or '648 Patents would have been obvious. Appx93-161; Appx341. The

ALJ also found that claim 28 of the '502 Patent and claim 12 of the '648 Patent were invalid for lacking written description of the claimed sets of LEDs. Appx167-170. The Commission reversed that finding, as explained below. The ALJ rejected Apple's remaining invalidity arguments. Appx161-175.

***Prosecution Laches:*** The ALJ found that Apple failed to show prosecution laches. Appx175-179; Appx341.

#### **4. The PTAB Rejects Apple's IPR Petitions**

Apple refers to ongoing litigation between the parties in California and an irrelevant jury note from that case. Br. 16. But that case was about trade secret misappropriation and did not involve the '502 or '648 Patents. Apple also fails to address that the PTAB rejected Apple's obviousness arguments in denying its IPR petitions.

In January 2023, shortly after the FID, the PTAB denied all six of Apple's IPR petitions on three Poeze Patents. As the Commission observed, Apple based three IPR petitions on the same Lumidigm reference that Apple presented to the Commission. Appx364-365 (citing Appx23904-23924; Appx23926-23946; Appx23876-23902). The PTAB explained several deficiencies in Apple's Lumidigm-based obviousness theories. *See, e.g.*, Appx23941 ("amalgamation of prior art teachings"); Appx23942 ("convoluted combination of modifications");

Appx23944 (“grounded in hindsight”). The PTAB also denied all six of Apple’s rehearing petitions. Appx27002-27003.

Before the IPR denials, Apple urged the Commission to take judicial notice of concurrent IPR proceedings concerning patents before the Commission, arguing that the Patent Office is the “lead agency in assessing patentability, or validity.” Appx23776 (citing Appx71038; Appx71045). The PTO also rejected Apple’s recent reexamination requests of the patents on appeal, which Apple filed after losing at the PTAB. Appx70957-71010; Appx71011-71035.

## **5. The Commission’s Review**

The parties each petitioned for review of specific issues in the FID. On May 15, 2023, the Commission determined to review portions of the FID and requested additional briefing. Appx24312-24318. That included: (a) the domestic industry finding on the Masimo patents on appeal; (b) the non-obviousness rulings with regard to those patents; and (c) the findings that claim 28 of the ’502 Patent and claim 12 of the ’648 Patent were invalid for lack of written description. Appx24313. The Commission determined not to review other parts of the FID. *Id.*

On October 26, 2023, the Commission issued its opinion, determining that Apple violated Section 337 by importing Apple Watches that infringe claims 22 and 28 of the ’502 Patent and claims 12, 24, and 30 of the ’648 Patent. Appx482-483. The Commission “affirm[ed] and adopt[ed] the ID’s findings, conclusions, and



supporting analysis that are not inconsistent with the Commission’s opinion.” Appx374. Below summarizes additional Commission findings and conclusions relevant to this appeal.

***Domestic Industry–Technical Prong:*** The Commission adopted the ALJ’s findings that Masimo satisfied the technical prong for claim 28 of the ’502 Patent based on the RevD and RevE Masimo Watch articles and for claims 12, 24, and 30 of the ’648 Patent based on the RevA, RevD, and RevE Masimo Watch articles, all of which first existed before the Complaint. *See, e.g.,* Appx425-426 (adopting Appx60-65; Appx73-90; Appx65-73). The Commission took no position whether post-Complaint evidence can be considered. Appx426.

***Domestic Industry–Economic Prong:*** Masimo relied on, *inter alia*, its employment of labor in researching and developing the Masimo Watch to satisfy the economic prong. *See, e.g.,* Appx306-311; Appx22539; Appx22554-22560. The Commission adopted the ALJ’s findings that Masimo satisfied the economic prong because Masimo’s employment of labor was significant. *See, e.g.,* Appx426-427; Appx306-311; Appx314-323. The Commission additionally found Masimo’s employment of labor on Masimo Watch research and development is quantitatively significant because it is almost 100% domestic. Appx426. The Commission took no position on the ALJ’s finding that Masimo had a domestic industry in the process of being established. *Id.*

***Infringement:*** Without further discussion, the Commission adopted the ALJ’s finding that the Apple Watches infringe the ’502 and ’648 Patent claims. Appx374; *see* Appx 31-60.

***Obviousness:*** The Commission affirmed the ALJ’s conclusion that Apple failed to show that the asserted claims would have been obvious. Appx375-412. The Commission rejected Apple’s argument that it would have been obvious to modify the Lumidigm embodiment relied on by Apple—a wristwatch—to measure oxygen saturation. Appx381-382. The Commission found that a POSITA would not have been able to modify Lumidigm’s wristwatch to measure oxygen saturation, and additionally that a POSITA would not have reasonably expected that modification to succeed. *See, e.g.*, Appx118-23.

The Commission affirmed the FID finding that Lumidigm and other prior art did not disclose the “optically transparent material within each of the openings” required by claim 22 of the ’502 Patent. Appx394-98. The Commission reversed the FID’s finding that the prior art disclosed similar limitations in claim 28 of the ’502 Patent and claims 12, 24, and 30 of the ’648 Patent. Appx400-402.

***Written Description:*** The Commission reversed the ALJ’s decision that claim 28 of the ’502 Patent and claim 12 of the ’648 Patent were invalid for lacking written description of the claimed sets of LEDs. Appx419-424.

***Prosecution Laches:*** The Commission did not mention the ALJ’s rejection of Apple’s prosecution laches defense and thus adopted the ALJ’s findings. Appx374. In denying Apple’s motion to stay, the Commission held that Apple had waived this defense by not properly petitioning for review of this defense. Appx27236-27237.

***Public Interest and Remedy:*** The Commission conducted a public-interest phase and received dozens of submissions from the public and the parties about whether to exclude the infringing articles. Appx365, Appx437-440. The Commission found a Section 337 violation, considered the public-interest factors, and issued a limited exclusion order and a cease-and-desist order with exemptions for service, repair, and replacement. Appx428; Appx435–477; Appx344-347; Appx348-355. Both the Commission and this Court have since denied Apple’s motions to stay the remedies pending this appeal. Appx27225-27229; Appx27230-27244; Dkt. 33.

#### **IV. SUMMARY OF THE ARGUMENT**

All of the Commission’s findings on appeal are supported by substantial evidence.

***Domestic Industry:*** In finding that Masimo had a domestic industry, the Commission did not exceed its statutory authority as Apple and amici argue. Nor did the Commission construe any statute. Rather, the Commission made extensive

factual findings supported by abundant evidence. The Commission found that Masimo invested millions of dollars employing dozens of engineers to research and develop Masimo Watch in California. Masimo designed, produced, and tested patent-practicing articles before the Complaint. The Commission credited the evidence that Masimo had tested such articles by measuring blood oxygen before filing the Complaint.

Apple ignores this abundant evidence to suggest that the Commission's domestic industry finding relied on a "fictitious product." Apple's challenge rests on its repeatedly rejected and false argument that Masimo's Complaint pointed only to CAD drawings as its patent-practicing articles and that the Commission was therefore limited to findings based on those drawings. Apple also ignores the extensive record regarding Masimo Watch development. Apple never mentions the Commission's finding that the Masimo Watch prototypes were all part of Masimo's "iterative design process."

Apple insists that domestic industry articles must precisely match the CAD drawings referenced in Masimo's Complaint. But Section 337 has no such requirement. Moreover, none of the alleged differences concern patented features, and the Commission may look at evidence beyond the Complaint.

Apple also attacks the Commission's finding that the domestic industry was the Masimo Watch project rather than individual prototypes. But that attack again

CONFIDENTIAL MATERIAL REDACTED

rests on the same incorrect narrative that Masimo “fails to identify an item that qualifies as an ‘article.’” Br. 4. And Apple ignores the Commission’s finding that Masimo employed **MASIMO CBI** employees, all in the U.S., to develop Masimo Watch. Apple also fails to recognize the deference given to the Commission in crediting testimony and other evidence explaining Masimo’s domestic industry.

***Non-obviousness:*** Abundant evidence supports the Commission’s findings that a POSITA would not have been able to make Lumidigm’s wristwatch measure blood oxygen. The Commission never required Lumidigm to disclose more detail than the patents on appeal because Apple failed to raise that comparison before the ALJ. Apple’s argument that the claims do not recite a wrist-worn device is irrelevant because Apple relied on the Lumidigm wristwatch. Thus, Apple needed to show that a POSITA would have been motivated to add pulse oximetry to that wristwatch.

Apple also presented no evidence supporting its finite-alternatives argument relating to the “separate windows” limitations. Regardless, Apple waived this theory by failing to petition the Commission for review.

***Written Description:*** Apple ignores the findings that its expert testimony was conclusory and insufficient to meet its burden on either of its theories. Further, Apple waived its mix-and-match argument by failing to adequately raise that argument in its petition for review.

***Infringement:*** Apple’s claim construction arguments ignore the intrinsic and extrinsic evidence and the findings based on that evidence. Apple now presents new arguments and evidence rather than showing any error in the ALJ’s detailed analysis.

***No Laches:*** The Commission found no evidence of any prosecution delay and Apple never cites the FID rejecting this defense. Regardless, Apple waived the defense by failing to adequately raise it in its petition for review.

## V. ARGUMENT

### A. Standard Of Review

This Court reviews Commission final determinations under the Administrative Procedure Act. 5 U.S.C. § 706; *Spansion, Inc. v. Int’l Trade Comm’n*, 629 F.3d 1331, 1349 (Fed. Cir. 2010). It reviews legal determinations *de novo* and factual findings for substantial evidence. *Spansion*, 629 F.3d at 1343. Under substantial evidence review, the Court “must affirm a Commission determination if it is reasonable and supported by the record as a whole, even if some evidence detracts from the Commission’s conclusion.” *Id.* at 1344. “This [C]ourt generally defers to an agency as fact-finder in assessing the credibility of witnesses.” *Alloc, Inc. v. Int’l Trade Comm’n*, 342 F.3d 1361, 1373 (Fed. Cir. 2003).

Apple’s “standard of review” section omits certain issues and includes some not at issue. Apple is correct that the Commission’s finding that Masimo established a domestic industry could present issues of both fact and law. Br. 22. But like the

case Apple cites, *Motiva, LLC v. Int'l Trade Comm'n*, 716 F.3d 596, 600 (Fed. Cir. 2013), “this appeal presents only factual issues,” which this Court reviews for substantial evidence. *Id.*; see *Broadcom Corp. v. Int'l Trade Comm'n*, 28 F.4th 240, 249-50 (Fed. Cir. 2022).

The Commission never had to interpret Section 337 to find a domestic industry as Apple argues. Br. 23, 27-28; see also Appx27235. Rather, the Commission applied the statute to Masimo’s pre-Complaint articles. Thus, Apple’s argument that this Court owes no deference to the Commission’s interpretation of a statute is irrelevant. Br. 23.

While obviousness rests on both legal and factual questions, Apple’s obviousness challenge is limited to factual findings concerning a single prior art reference, such as what it teaches and whether a POSITA would have been successful in modifying an embodiment shown in that reference. See *Philip Morris Prods. S.A. v. Int'l Trade Comm'n*, 63 F.4th 1328, 1348 (Fed. Cir. 2023). Whether a prior art reference is enabled presents a question of law based on underlying factual findings, *Raytheon Techs. Corp. v. Gen. Elec. Co.*, 993 F.3d 1374, 1380 (Fed. Cir. 2021), but only factual findings are at issue here.

The parties agree that whether the specification provides written description for a claim under 35 U.S.C. § 112 presents a question of fact. The parties also agree on the standard of review for claim construction. Br. 22.

Apple recognizes that this Court reviews rulings on prosecution laches for an abuse of discretion. Br. 23. Apple asserts that this Court “reviews the legal standard applied by the tribunal *de novo*.” *Id.* But that is irrelevant because Apple is not challenging the legal standard applied. Moreover, because Apple did not adequately raise its laches defense in its petition for review, Apple waived that defense under the Commission’s rules. *See* 19 C.F.R. § 210.43(b)(2). When denying Apple’s motion for a stay, the Commission held that Apple waived the defense. Appx27236. This Court reviews waiver findings for an abuse of discretion. *Winbond Elecs. Corp. v. Int’l Trade Comm’n*, 262 F.3d 1363, 1370 (Fed. Cir. 2001).

Finally, as addressed below, this Court need not review numerous arguments that Apple failed to properly raise before either the ALJ or the Commission because Apple has waived those arguments. *E.g.*, *Broadcom Corp. v. Int’l Trade Comm’n*, 542 F.3d 894, 901 (Fed. Cir. 2008) (not raised to ALJ); *Finnigan Corp. v. Int’l Trade Comm’n*, 180 F.3d 1354, 1362-63 (Fed. Cir. 1999) (not specifically raised in petition for review).

**B. Substantial Evidence Supports The Commission’s Findings That Masimo Made Patented Articles Before The Complaint**

Apple argues the Commission “exceeded its statutory authority” by interpreting the term “article” of Section 337 to include a “hypothetical article” depicted in CAD drawings to find a domestic industry. Br. 27. But the Commission never had to interpret the statute or find that CAD drawings were the articles



satisfying the statute. Instead, the Commission found that Masimo had numerous physical articles satisfying the technical prong. Appx64-90; Appx27235. Abundant evidence supported that finding, including physical exhibits, documents, and witness testimony.

1. **Apple Ignores Masimo's Development Activities Years Before The Complaint**

Extensive evidence showed Masimo's project to develop a wrist-worn device that measures oxygen saturation since at least 2014. *Supra* Section III.B. Apple never mentions this evidence.

2. **Apple Dismisses The Abundant Evidence Of Masimo's Pre-Complaint Patent-Practicing Articles**

Masimo made patent-practicing articles before the Complaint as part of the Masimo Watch project, including RevA, RevD, and RevE. The back surfaces of these devices are pictured below:

CONFIDENTIAL MATERIAL REDACTED

Rev A

(28089A)

Rev D

MASIMO CONFIDENTIAL BUSINESS INFO

Rev E

(28089E)

MASIMO CONFIDENTIAL BUSINESS INFO

Appx65025 (RevA); Appx65031 (RevD); Appx65015 (RevE); Appx65017 (RevE);  
Appx65033 (RevE).

The Commission found Masimo Watch was developed “as part of an iterative design process.” Appx373. Masimo presented extensive evidence to support this finding. See Appx40436-40437(342:25-343:7) (Masimo executive describing “many iterations of wrist sensors”); Appx40439(345:2-7) (describing “[m]any iterations on the watch through the design phases”); Appx40487(393:12-20) (“... we’ve designed, built, and tested many iterations of the Masimo Watch”); Appx40496(402:2-12) (describing “the progression of the different sensor

designs”); Appx40347(254:4-12); Appx40350-40351(257:21-258:4); Appx40354 (261:6-16) (discussing iterations of designs).

Masimo made patent-practicing RevA, RevD, and RevE watches before the July 12, 2021 Complaint. Appx40490(396:2-16) (design of RevA in 2020); Appx40491(397:7-24) (progression to RevD by April 2021); Appx40492(398:1-23) (three RevE built between May and September 2021); Appx40551(457:9-21) (software loaded on RevE watch (Appx65014-65015) on July 9, 2021); Appx70486 (identifying May 2021 release date for RevE sensor). Masimo tested these watches to confirm their blood-oxygen accuracy. Appx40368(275:13-20) (every sensor design is tested); Appx40369-40371(276:12-278:13) (testing of RevD watches to confirm clinical accuracy); Appx40410-40411(316:2-317:20) (describing June 2021 testing of RevE sensors (*e.g.*, Appx53256)). Masimo’s expert explained how these watches practiced the claims. Appx40805-40822(710:23-711:10); Appx40806-40812(711:14-717:21); Appx40815-40821(720:21-726:14).

**3. Substantial Evidence Supports The Commission’s Finding That Masimo Satisfied The Technical Prong**

The Commission spent over thirty pages analyzing the technical prong for the Poeze Patents. Appx60-92; Appx425-426; Appx374. The Commission confirmed “[t]here is no dispute that the RevA and RevD sensors were made before the filing of the Complaint—Mr. Scruggs explained that Masimo built the RevA sensor in November 2020, and the RevD sensor in April 2021.” Appx64 (citing

Appx40490-40491(396:2-13, 397:7-24)). For the RevE device, “[t]he evidence shows that at least one of the RevE devices produced (CPX-0019C [Appx65014-65015]) existed at the time of the complaint.” Appx89. The Commission relied on testimony describing Masimo’s testing of RevE devices in June 2021. Appx89-90 (citing Appx40410-40411(316:2-317:20)); *see also* Appx53256-53361 (June 2021 testing).

The Commission also conducted a “limitation-by-limitation analysis for the RevA, RevD, and RevE devices,” Appx65-87, and concluded that the RevD and RevE devices practiced claim 28 of the ’502 Patent and that the RevA, RevD, and RevE devices practiced claims 12, 24, and 30 of the ’648 Patent. Appx84-87. The Commission relied on technical documents and drawings of the devices, testimony from Masimo witnesses describing the functionality of these devices, observations from Masimo’s technical expert regarding demonstrations of these devices, descriptions of internal testing by Masimo’s witnesses, and evidence of Masimo’s testing results. *See, e.g.*, Appx60. The Commission also concluded that “the RevA, RevD, and RevE devices have been shown to be articles protected by claims of the Poeze patents existing at the time of the complaint.” Appx88; *see* Appx90.

**4. Apple’s Challenge Of The Commission’s Domestic Industry Analysis Is Without Merit**

Apple makes three erroneous arguments against the Commission’s domestic industry findings.

a. **Apple’s Argument That The Commission Relied On A “Hypothetical Article” Ignores The Evidence And The Commission’s Holding**

Apple repeatedly accuses the Commission of relying on a “purely hypothetical” or “fictitious product” identified in the Complaint “that theoretically might exist in the future.” Br. 4, 20, 27, 29. Apple ignores the Commission’s lengthy analysis of the extensive evidence that RevA, RevD, and RevE articles were made before the Complaint was filed, and the finding that Masimo Watch was an “iterative design process” and not merely isolated CAD drawings referenced in the Complaint. Appx373; Appx40367-40368(274:11-275:3); Appx40436-40437(342:25-343:7); Appx40439(345:2-7); Appx40487(393:12-20); Appx40488-40492; Appx40496(402:2-12); Appx40347(254:4-12); Appx40350-40351(257:21-258:4) Appx40354(261:6-16); Appx65066-65074; Appx65018-65019; Appx65022-65023; Appx65024-65025; Appx65030-65031; Appx65014-65015; Appx65016-65017; Appx65032-65033.

The domestic industry statute addresses the entire industry “relating to” the patented articles. 19 U.S.C. § 1337(a)(2). The Commission found Masimo’s prototypes leading to the patented prototypes were part of the Masimo Watch domestic industry. Appx308-309. Because the Masimo Watch project was iterative, RevA, RevD, RevE, and other Masimo Watch articles were interrelated. Appx309

(Circle and Wings prototypes “led to the development of the RevA, RevD, and RevE prototypes”); Appx67; Appx92.

Apple wrongly restricts its analysis to CAD drawings as if they were a supposed “article” that “theoretically *might* exist in the future.”<sup>5</sup> Br. 4 (emphasis in original). Nothing supports Apple’s argument that the Commission must confine its technical prong analysis to the representative CAD drawings in Masimo’s Complaint and ignore the extensive evidence presented during the five-day hearing. Br. 26. Apple’s argument also contradicts the Commission’s Rules, which provide that the Commission bases its decision on the full record. *See* 19 C.F.R. §§ 210.38 (defining the expansive breadth of the record), 210.45(c) (Commission free to “make any findings or conclusions that in its judgment are proper based on the record in the proceeding.”). The Commission properly considered the abundant evidence to confirm the existence of a domestic industry at the time of the Complaint.

Attempting to restrict the Commission to the CAD drawings in the Complaint, Apple argues as if future versions of Masimo Watch would be “speculative *future violations*.” Br. 25 (emphasis in original). Apple confuses the fundamental difference between Masimo’s domestic industry and Apple’s importation violations. *Id.*; *see id.* 28 (“a CAD drawing does not move in commerce and cannot be seized

---

<sup>5</sup> Emphasis is added unless otherwise noted.

or forfeited.”). The violation that gave rise to the Complaint was Apple’s importation and sale of foreign-made infringing Apple Watches, not Masimo’s domestic industry relating to Masimo Watch.<sup>6</sup>

Regardless, as explained above, and as the Commission found, Apple’s arguments rest on misreading the Complaint. Appx14136-14137 (“Apple has misread the Amended Complaint ...”). As the Commission repeatedly found, the Complaint never suggested Masimo had only one version of “the Masimo Watch.” Appx14136-14138; *see supra* Section III.E.1. Per Commission rule, the Complaint described the CAD drawings as “representative” of a Masimo Watch.<sup>7</sup> Appx3733 ¶ 89 (attaching Appx2740-2758 (Ex. 21)). Even Apple admitted that “Confidential Exhibits 20 and 21 purport to be visual *representations* of Masimo’s products.” Appx4591 ¶ 89. Moreover, Apple omits that the FID found that testimony regarding the Complaint’s CAD drawings “confirm[ed] the accuracy of the CAD drawings for the RevE sensor.” Appx70 (citing Appx40407-40408

---

<sup>6</sup> Apple’s reliance on Article III’s “jurisdictional requirements” is misplaced. *See Certain Active Matrix Organic Light-Emitting Diode Display Panels and Modules for Mobile Devices*, Inv. No. 337-TA-1351, EDIS Doc. ID. 821542, Comm’n Op. (May 15, 2024) at 2, 12, 13 (constitutional standing requirements do not apply to the Commission). Moreover, the ITC can also protect industries that are in the process of being established. 19 U.S.C. § 1337(a)(2).

<sup>7</sup> 19 C.F.R. § 210.12(a)(9)(ix) provides that a complaint should include a claim chart applying the asserted patents to “*a representative* involved domestic article.”

(313:14-314:7)); *see also* Appx60136-60153 (CAD drawing discussed at Appx40407-40408).

Apple also attempts to mandate that the physical article must precisely “match” the CAD drawings in the Complaint. Br. 3, 19, 27, 29. Apple identifies no support for such a requirement. The ALJ credited testimony from Masimo’s engineer “that ‘the essential meat and potatoes stuff, like the sensor, it’s very accurately reflected’ by the CAD drawings, because ‘that’s very important for the devices.’” Appx70 (quoting Appx40561(467:2-7); Appx40571-40572(477:9-478:8) and citing Appx40407-40408(313:14-314:7)). Apple did not identify any difference in the CAD drawings relating to patent-practicing features. *See, e.g.*, Appx70620-70621(91:18-92:24) (discussing “metal electrodes” (for ECG) and “wireless-charging coil”).

**b. The Commission Is Free To Rely On Circumstantial Evidence**

Apple argues that “Masimo failed to offer any *direct* evidence” that its domestic industry articles could practice the asserted claims at the time of the Complaint and criticizes the Commission’s reliance on circumstantial evidence. Br. 30. Apple focuses on the FID’s findings regarding prototype designs “consistent with” the asserted domestic industry products and argues that the Commission’s findings “rely[] on circumstantial evidence to speculate that [the RevA, RevD, and RevE devices] could measure blood oxygen as the claims require.” *Id.*



Apple cites no authority to support its view that the Commission cannot rely on circumstantial evidence. This Court has recognized that circumstantial evidence is appropriate. *See Moleculon Research Corp. v. CBS, Inc.*, 793 F.2d 1261, 1272 (Fed. Cir. 1986) (“Circumstantial evidence is not only sufficient, but may also be more certain, satisfying and persuasive than direct evidence.”) (quoting *Michalic v. Cleveland Tankers, Inc.*, 364 U.S. 325, 330 (1960)).

Apple also ignores the substantial direct evidence Masimo presented. Masimo’s witnesses testified that all software versions for Masimo Watch could determine oxygen saturation and pulse rate. Appx40440(346:6-19); Appx40570 (476:1-4). Masimo presented evidence of clinical studies using watches with its RevA (Appx40365-40368(272:16-275:12); Appx53107; Appx53137-53138; Appx53144-53148), RevD (Appx40369(276:12-277:12) (discussing Appx65030-65031)), and RevE (Appx40407-40411(313:14-317:20); Appx53256; Appx53258; Appx53260; Appx53262-53263; Appx53266; Appx53268-53269; Appx53272-53273) designs to prove its watches measured oxygen saturation before the Complaint. Masimo also introduced physical samples of its RevA, RevD, and RevE watches. *See supra* Section V.B.2.

In addition to the CAD drawings accurately depicting the relevant features of the RevA, RevD, and RevE watches (Appx55389-53390; Appx55391-55393; Appx55394-55399; Appx60136-60153; Appx55368-55376; Appx55359-55367),

the Commission also relied on internal documents, technical drawings, and circuit diagrams underlying the designs in its analysis. *See, e.g.*, Appx53107-53151; Appx53222-53225; Appx53226-53229; Appx53236-53248; Appx53249-53252; Appx53362-53365; Appx53813-53818; Appx53820-53826; Appx53827-53831; Appx53832-53838. Thus, the Commission relied on both circumstantial and direct evidence to support its domestic industry finding.

c. **Apple Cannot Dismiss The Evidence Supporting The Commission’s Technical Prong Findings**

Apple asserts “[t]here is no non-speculative evidence of record that (1) four of the five items the ALJ relied on existed when the complaint was filed or (2) *any* item practiced the asserted claims.” Br. 31 (emphasis in original).

Apple blames the Commission for considering devices created *before* the filing of the Complaint simply because those devices may have been altered later. Br. 32-33. Those “alterations” merely updated the firmware version and did not change the calculation of oxygen saturation. *See, e.g.*, Appx40487(393:12-20) (all iterations of Masimo Watch “supported the ability to measure oxygen saturation”); Appx40501-40502(407:22-408:4) (describing RevD functionality), Appx40504(410:1-4) (confirming the same operation for RevD and RevE), Appx40499-40500(405:8-406:11) (describing RevA functionality). Masimo’s witness explained that “the core functionality of the firmware, which is the calculation of oxygenation, has not changed.” Appx40440-40441(346:20-347:1); *see also* Appx40439-

40441(345:21-347:4); Appx40570(476:1-4); Appx40365-40371(272:16-278:3) (describing Appx53138, Appx53242, and testing of oxygen saturation with RevA and RevD); Appx40353-40361(260:11-268:21); Appx40410-40411(316:2-317:20) (describing Appx53256-53361 and RevE device testing in June 2021); Appx53107-53151; Appx53242; Appx40412(318:15-22). The Commission cited much of this evidence, finding Masimo “explicitly identified testing of blood oxygen functionality conducted in 2020 using prototype designs consistent with the RevA sensor, additional testing in the timeframe of the RevD devices in early 2021, and further testing of RevE devices in June 2021.” Appx66-67; Appx67 n.16.

Apple next argues that “there was no evidence” that RevA and RevD practiced the asserted claims because the physical exhibits were not “user-worn” without a strap. Br. 33-34. But the evidence showed those articles included a strap before the Complaint. Appx40499-40500(405:8-406:3) (RevA had a “mechanism for attaching a strap, which it had at one point in time.”); Appx40500-40501(406:23-407:18) (RevD). The Commission also found that Masimo’s witness testimony describing “testing relating to the Masimo’s RevA and RevD sensors in the fall of 2020 and early 2021 ... suggests that the devices were ‘user-worn.’” Appx68 (citing Appx40353-40371(260:11-265:14, 265:15-268:21, 270:17-22, 276:12-278:3); Appx40371(278:5-13)).

CONFIDENTIAL MATERIAL REDACTED

Apple also argues that substantial evidence does not support the Commission's finding that the domestic industry articles measure blood oxygen. Br. 36-37. But, as explained above, all iterations of Masimo Watch could measure oxygen saturation.

Apple argues “[t]he only meaningful evidence regarding the RevA item’s functionality came from Apple’s experts” based on a demonstration. Br. 34. Apple never addresses the abundant evidence cited above or why that evidence is supposedly not “meaningful.” That demonstration also confirmed the RevA, RevD, and RevE sensors measured oxygen saturation. The devices showed blood oxygen saturations from between 98-100, which, as explained in the FID, is a variation consistent with FDA guidance regarding the acceptable error in pulse oximetry. Appx67 n.18. Masimo is the world leader in pulse oximetry, and Apple’s argument that Masimo’s articles were unable to determine oxygen saturation is baseless.

**C. Substantial Evidence Supports The Commission’s Finding That Masimo Satisfied The Economic Prong**

The Commission found that Masimo showed “the existence of a domestic industry by way of significant employment of labor with respect to Masimo’s investments in research and development for the Masimo Watch.” Appx426. The Commission based that finding on Masimo’s **MASIMO CBI** employees “representing over **MASIM** percent of Masimo’s research and development engineers.” *Id.* The Commission observed that this “employment of labor is quantitatively significant

because the identified employment of labor is almost one hundred percent domestic.” *Id.* (citing Appx322; Appx40415-40416(321:23-322:5)); *see also* Appx5306(AppxS) (excerpted as Appx71241-71244); Appx40598(504:9-13); Appx40211-12(118:24-119:12). Apple does not dispute that Masimo’s employment was significant. Indeed, it never mentions Masimo’s headcount and thus ignores that basis for the Commission’s finding.

1. **Apple Fails To Show Error In The Commission’s Holding That Masimo Employed Significant Labor On Masimo Watch**

Apple argues that the Commission mistakenly allowed Masimo to show significant employment of labor for unpatented articles. Br. 37-38. Apple argues this Court “recognized as much” in *Microsoft Corp. v. Int’l Trade Comm’n*, 731 F.3d 1354, 1361 (Fed. Cir. 2013). Br. 38.

Apple distorts *Microsoft*. There, Microsoft did not allege that its operating system practiced the asserted patents. 731 F.3d at 1363. Instead, it argued that third-party devices practiced the patents when running portions of its operating system. *Id.* at 1361. But no evidence showed that anyone had ever loaded those portions of the operating system onto any device. *Id.* Thus, this Court affirmed that no patent-practicing article ever existed. *Id.*

Apple misleadingly argues that this Court held that “it was ‘not enough’ that Microsoft had made substantial investments in an item *related* and important to the patent-practicing article (*e.g.*, its operating system)[.]” Br. 38 (emphasis in original).

But because Microsoft failed to satisfy the technical prong, there was no domestic industry to analyze in the economic prong. *See* 731 F.3d at 1361.

Apple also quotes the Commission’s criticism of “aggregating investments in different domestic industry products that practice different patents.” Br. 38 (quoting *Certain Electronic Stud Finders*, Inv. No. 337-TA-1221, 2022 WL 834280, at \*28 (ITC Mar. 14, 2022), *aff’d sub nom*, *Zircon Corp. v. Int’l Trade Comm’n*, 101 F.4th 817 (Fed. Cir. 2024). But Masimo never aggregated its investments across all five asserted patents.<sup>8</sup>

Moreover, Apple ignores that the Commission properly rejected Apple’s reliance on *Electronic Stud Finders*. It adopted the FID’s finding that “unlike the different products at issue in *Electronic Stud Finders*, the evidence indicates that the Masimo Watch prototypes are merely ‘iterations’ of a product design that was continuously developed in the years leading up to the filing of the complaint.” Appx308 (citing Appx40436-40439(342:25-343:7, 345:2-7); Appx40487(393:12-20); Appx40496(402:2-12); Appx40368-40369(275:13-276:11)).

Apple misleadingly quotes the FID noting that “Complainants have not asserted that the Circle sensor or the Wings sensor practice claims of the Poeze

---

<sup>8</sup> Masimo relied on a different product line for Masimo’s U.S. Patent No. 7,761,127, and a different grouping of Masimo Watch articles for U.S. Patent No. 10,687,745. *See* Appx309 n.117; Appx329. Those patents are not on appeal.

patents.” Br. 39 (quoting Appx309). Apple omits the rest of the sentence: “*but* the record shows that the development of these prototypes led to the development of the RevA, RevD, and RevE prototypes that Complainants have asserted as domestic industry products for the Poeze patents.” Appx309. Work on prototypes leading to patent-practicing articles are obviously part of Masimo’s investment in the domestic industry “relating to” or “with respect to” these articles. Section 337(a)(2)-(3).

Masimo proposed its domestic industry investments should include foundational research and development on wrist-worn technology, even though that research was useful for both the Masimo Watch project and other projects. Appx21425. Apple sought to limit the domestic industry to each prototype. Appx21741-21742; Appx21748-21749. The Commission reached an intermediate position by finding the domestic industry was the Masimo Watch project. Appx308. The Commission found that “Masimo’s investments in the development of Masimo Watch prototypes can be aggregated for the economic prong analysis.” *Id.*

Apple next argues that the Commission allowed Masimo to aggregate its expenses “in light of testimony from Masimo’s CFO that ‘Masimo’s financial records did not track expenditures at’ a sufficient level of detail to separate out Circles/Wings from other purported articles.” Br. 39 (quoting Appx308). But the Commission recognized the nature of the iterative design process of the Masimo Watch, and that all the Masimo Watch-specific development work “resulted in the

CONFIDENTIAL MATERIAL REDACTED

W1 Watch.” Appx373. The Commission properly credited Masimo’s investments in these prototypes because they were part of same iterative process.

**2. The Commission Properly Relied On Substantial Evidence Quantifying Masimo’s Domestic Employment**

The Commission found Masimo’s employment for research and development of Masimo Watch significant because it represented over [REDACTED] % of Masimo’s research and development engineers, and because it was almost 100% domestic. Appx426. Apple criticizes the Commission’s finding that Masimo invested [REDACTED] in Masimo Watch R&D labor, arguing that Masimo provided no “contemporaneous documents” but only “post-hoc spreadsheets” that “appear to lack any basis in reality.” Br. 41.

Apple ignores that the Commission relied on “the time allocations for Masimo’s employees” which were “similar to evidence that has been relied upon in other investigations.” Appx316. The Commission further found that Masimo had “identified the names and salaries of each employee involved in the Masimo Watch project with monthly estimates of their time from 2019 to 2021.” *Id.* The Commission also found that Masimo “provide[d] a similar accounting for executive labor” and “identif[ied] expenditures for recruiting engineers to work on the Masimo Watch.” Appx316-317.

The Commission has recognized that “there is no Commission requirement that sworn witness testimony directed to the domestic industry requirement cannot



## CONFIDENTIAL MATERIAL REDACTED

be credited without further corroboration by underlying documentation.” *Certain Raised Garden Beds*, Inv. No. 337-TA-1334, EDIS Doc. ID. 817237, Comm’n Op. (Apr. 1, 2024) at 45 (citing *Certain Solid State Storage Drives*, Inv. No. 337-TA-1097, EDIS Doc. ID. 649139, Comm’n Op. at 20-22 (June 29, 2018)); see *Zircon Corp.*, 101 F.4th at 829 (written records are not required to credit testimony).

Apple criticizes that Masimo’s nine executives devoted the same percentages (e.g., [REDACTED] and [REDACTED]) across the months, unlike the dozens of employees whose allocations varied from month to month. Br. 41. But the Commission credited Masimo’s CFO who explained the allocations were conservative. Appx317 (quoting Appx40587-40588(493:14-494:6)). Apple also argues that Masimo’s allocations were “prepared by the same Masimo personnel using an unexplained methodology.” Br. 41. But the Commission found that these domestic expenditures “have been reliably quantified for consideration as part of the alleged domestic industry in this investigation.” Appx316.

### **3. Apple’s Policy Arguments Are Baseless**

Apple cannot genuinely argue the Commission “failed to police the domestic industry boundary line.” Br. 44. The Commission considered the evidence, made detailed findings, and found Masimo satisfied the domestic-industry requirement. Appx22-24; Appx60-92; Appx306-329; Appx341. It is Apple, not the Commission, who hopes to change the rules. See Br. 43-44; see also Appx71245-71250 (Tripp

Mickle, *Apple Keeps Losing Patent Cases. Its Solution: Rewrite the Rules*, NEW YORK TIMES (Mar. 19, 2024)).

**D. Substantial Evidence Supports The Commission Findings Underlying Its Rejection Of Apple’s Obviousness Defense**

Apple challenges only certain Commission findings concerning one prior art patent to Lumidigm. The Commission, supported by substantial evidence, rejected Apple’s obviousness defense twice-over. First, the Commission found Apple failed to show that “a user-worn device” configured to measure oxygen saturation would have been obvious. The Commission found Lumidigm was not enabling of a user-worn device configured to measure oxygen saturation. The Commission also found a POSITA would have had no reasonable expectation of success in modifying Lumidigm’s wristwatch to measure oxygen saturation. Second, the Commission found that Apple failed to show that the limitations requiring separate “windows” or “material” over separate openings would have been obvious.

Apple cannot fault the Commission’s focus on Lumidigm’s wristwatch. Apple’s obviousness theory required a POSITA to modify Lumidigm’s wristwatch to add pulse oximetry. Now, Apple can contest only the Commission’s factual findings concerning Lumidigm—not any legal issue. What Lumidigm teaches is a question of fact. *See Orion IP, LLC v. Hyundai Motor Am.*, 605 F.3d 967, 975 (Fed. Cir. 2010). Because abundant evidence supports the Commission’s findings, Apple cannot show error.

1. **Apple Cannot Show Any Error In The Commission Examining Whether A POSITA Could Modify Lumidigm To Measure Blood Oxygen At The Wrist**

Apple argues that, because the patents are not specific to measuring at the wrist, the Commission “committed legal error by requiring Lumidigm to render obvious *more* than the asserted patents disclose or the asserted claims require.” Br. 45-46 (emphasis in original). The Commission did no such thing. In denying Apple’s stay motion, the Commission rejected Apple’s argument:

Apple misconstrues the Final ID, and Apple’s argument (also presented in its petition for review of the Final ID) was already considered and rejected by the Commission. *See* [Appx23629-23634]. Neither the Final ID nor the Commission required Lumidigm to enable more than the asserted patent claims. *See* [Appx23792-23794].

Appx27238. The Commission properly analyzed whether a POSITA “would have been motivated to modify Lumidigm’s wristwatch to measure oxygen saturation to arrive at the alleged invalidating device with a reasonable expectation of success.” *Id.*

Apple also criticizes the Commission for requiring Lumidigm to measure oxygen saturation at the wrist when the claims do not recite measuring “at the wrist.” Br. 45. But Apple’s obviousness theory required a POSITA to measure oxygen saturation at the wrist by modifying Lumidigm’s *wristwatch*. Appx21562-21563; Appx21571-21572; Appx21580-21581; Appx21590-21592. In denying Apple’s stay motion, the Commission rejected Apple’s argument:

While measuring oxygen saturation at the wrist is not claimed, Apple chose to base its invalidity theory on measuring blood oxygen saturation at the wrist being taught or suggested by Lumidigm to a person of ordinary skill in the art at the time of the invention.

Appx27238.

The Commission explained that it “properly found that Lumidigm, alone or combined with knowledge in the art at the time of the invention, did not enable measuring oxygen saturation at the wrist” and that “a person of ordinary skill in the art would not have reasonably expected success at arriving at the device serving as the basis of Apple’s obviousness theory.” *Id.*

Accordingly, the Commission correctly examined whether a POSITA would have been able to make and use the modified Lumidigm wristwatch Apple relied on for obviousness. *See, e.g., Raytheon*, 993 F.3d at 1380-81 (evidence “must enable the portions of [the reference’s] disclosure being relied upon” for obviousness). The ALJ did not go “out of her way to emphasize the ‘significant difficulty of performing pulse oximetry at the wrist.’” Br. 48. The ALJ required Apple simply to prove its own obviousness theory.

Apple argues that the Commission should have compared Lumidigm’s disclosure to that of the asserted patents in evaluating whether Lumidigm enabled measuring oxygen saturation with its wristwatch. Br. 45-48. Apple admits it never made this comparison argument to the ALJ, Br. 46 n.16, and thus waived the issue. Apple shifted to this new argument only after the FID found Lumidigm was not

enabled for pulse oximetry and then argued the asserted patents are invalid for lack of enablement. Appx23630-23631. Before the FID's finding, Apple never argued that the asserted patents fail to enable pulse oximetry for the recited user-worn device, as it now argues. Br. 48.

Regardless, it would have been error for the Commission to do the comparison Apple belatedly advocates. First, Apple's enablement argument concerning the asserted claims was never before the ALJ. Second, enablement of the asserted patents requires looking at the disclosure relative to the asserted claims. *Transocean Offshore Deepwater Drilling, Inc. v. Maersk Drilling USA, Inc.*, 699 F.3d 1340, 1355 (Fed. Cir. 2012). On the other hand, enablement of a prior art reference requires looking to see whether a disclosed embodiment, as relied upon by the patent challenger, is enabled. *Raytheon*, 993 F.3d at 1380-81. The two patent prosecution cases Apple cites do not require the Commission to compare the asserted patents' disclosure with the prior art's disclosure before finding the prior art not enabling. Br. 47 (citing *In re Epstein*, 32 F.3d 1559, 1568 (Fed. Cir. 1994); *In re Paulsen*, 30 F.3d 1475, 1481 n.9 (Fed. Cir. 1994)).

And even if Apple had accurately represented the law, Apple's argument rests on the assumption that Lumidigm enables an embodiment that performs pulse oximetry. Br. 48. But as discussed below, the Commission concluded otherwise.

2. **Abundant Evidence Supports The Commission’s Finding That A POSITA Would Not Have Had A Reasonable Expectation Of Success In Modifying Lumidigm To Measure Blood Oxygen At All**

Apple’s arguments rest on the mistaken assumption that Lumidigm enables pulse oximetry somewhere on the body. Br. 48-49. Apple ignores the Commission’s findings that Lumidigm does not disclose measuring oxygen saturation at all. Appx138 (“[Lumidigm] does not include the communication of an oxygen saturation measurement ... because no such measurement is disclosed in Lumidigm.”); Appx120 n.40 (“There is little to no technical description of the blood oxygen functionality in Lumidigm, let alone in the wristwatch embodiment specifically.”).

Despite these findings, Apple argues that the ALJ “rightly found that the disclosed pulse oximetry functionality [of Lumidigm] was ‘clearly applicable to the user-worn wristwatch’ embodiment.” Br. 49 (citing Appx95). But on the cited page, the ALJ actually found that the Lumidigm wristwatch was “configured to measure a physiological parameter,” language of a patent claim not on appeal. Appx95 (citing Lumidigm’s disclosure of monitoring physiological parameters such as alcohol and bilirubin, not oxygen saturation).

Apple builds on its misrepresentation by arguing, “[g]iven this express disclosure of a wrist-worn device for taking an oxygen saturation measurement, Lumidigm is *presumed* to enable pulse oximetry at the wrist.” Br. 49. But Apple identifies no such “express disclosure” in Lumidigm because, as the Commission

found, there is none. Appx120 n.40; Appx138; *see* Appx41427-41428 (1330:20-1331:11) (Masimo’s expert explaining Lumidigm does not disclose measuring oxygen saturation).

Abundant evidence supports the Commission’s finding that Apple failed to present clear and convincing evidence that a POSITA “would have been enabled to measure oxygen saturation in the Lumidigm wristwatch” at the time of the Poeze Patents. Appx119; Appx97 n.29; Appx118-123; Appx129; Appx133; Appx137; Appx145-147.

Even if Lumidigm, as a U.S. patent, were presumed to enable measuring oxygen saturation, the Commission found Masimo rebutted that presumption with “persuasive evidence that [POSITAs] would not have expected to successfully measure blood oxygen in a wristwatch at the time of the Poeze patents.” Appx120. As a result, the Commission concluded that “[o]n the evidence of record, the presumption of enablement is overcome with respect to configuring Lumidigm’s wristwatch to measure blood oxygen at the time of the Poeze patents.” Appx122. Apple fails to address much of the evidence supporting this finding. And Apple mischaracterizes the evidence it does address.

Apple argues “unrebutted expert testimony confirmed a person of ordinary skill ‘would not have needed any additional information to make [pulse oximetry functionality] work’ on the wrist.” Br. 49 (citing Appx41313). But Masimo

CONFIDENTIAL MATERIAL REDACTED

thoroughly rebutted the conclusory testimony from Apple's expert. For example, the Commission found that Robert Rowe, the primary inventor on the Lumidigm patent, "acknowledged that he never made a device that calculated blood oxygen at Lumidigm, Inc." Appx120 (citing Appx52605-52606(118:4-119:8)).

The Commission also detailed the testimony of Apple engineers about the significant difficulty of measuring oxygen saturation at the wrist, even years after Lumidigm. Appx120-121 (citing Appx41108-41109(1012:12-1013:6); Appx41094-41095(998:21-999:6); Appx53017-53018(166:4-167:5); Appx52940(108:13-21)). The Commission found that a 2015 Apple presentation (Appx51900-51924) corroborated this testimony. Appx121 (citing Appx51912 ("APPLE CBI APPLE CBI," to measure oxygen saturation at the wrist); Appx41079(983:2-12)); *see* Appx154-156 (citing additional Apple engineer testimony such as Appx41034(938:21-24)). Accordingly, abundant evidence supports the Commission's findings that a POSITA would not have been able to modify Lumidigm's wristwatch to measure oxygen saturation, or reasonably expected that modification to succeed. Appx119-123.

Apple also ignores the Commission's findings explaining the inadequacy of Warren's testimony. It found that Warren "provided no testimony regarding the results of [any] measurements," and that Apple identified no "measurements of oxygen saturation at the wrist in the corroborating documents provided by



Dr. Warren.” Appx122 (finding that Warren’s poster (Appx70424) presents only “data from finger and head” and Warren’s paper (Appx70431; Appx70436) presents only “data from the thumb”). The Commission “agree[d] with Complainants that there is no prior art enablement of a wristwatch that measures blood oxygen.” Appx97 n.29; *see* Appx121-122.

Apple concludes by arguing “nothing in Lumidigm suggests that the wristwatch embodiment could not be worn elsewhere on the body (e.g. upper arm or ankle); if Lumidigm’s wristwatch could measure blood oxygen *anywhere* on the body (it could), it would disclose (and enable) the claimed subject matter.” Br. 49. Apple never made this argument to the ALJ and thus cites nothing to support it. *Id.*; Appx22703-22773; Appx22985-22999. Further, Apple’s untimely argument rests on its misrepresentation that the ALJ found that Lumidigm disclosed measuring blood oxygen on the wrist. But Apple ignores all the above-described findings that Lumidigm discloses no such measurement. Appx120 n.40; Appx97 n.29. Moreover, Lumidigm’s wristwatch is for the wrist, not other parts of the body.

**3. Substantial Evidence Supports The Commission’s Finding That Lumidigm Does Not Teach Or Suggest The Claimed “Transmissive Windows” Or “Optically Transparent Material”**

Apple challenges the Commission’s findings that Lumidigm does not teach or suggest separate “transmissive windows” or “optically transparent material” extending across or within openings. Br. 50-54; Appx394-402. Before the

Commission, Apple relied on the “Cramer” patent or the knowledge of a POSITA to modify Lumidigm to add the recited windows or optically transparent material. Appx23710-23711; Appx22395-22399; Appx21883-21885. Thus, the Commission correctly observed that “Apple acknowledges that Lumidigm does not teach the separate optically transparent materials (or windows).” Appx394.

Moreover, the Commission found “none of the prior art cited by Apple teaches or suggests separate optically transparent materials (or windows).” Appx394. The Commission also found that Apple failed to present clear and convincing evidence that a POSITA would have had a reason to modify Lumidigm to create the claimed inventions. Appx395; Appx402. The Commission explained that Apple’s expert “testified only about what a [POSITA] *could* do, not what such a person *would* do. Appx395 (emphases in original) (citing Appx23587; Appx23524-23525; Appx41290-41291(1193:24-1194:14); Appx41318-41319(1221:16-1222:25); Appx41332-41333(1235:24-1236:2)). The Commission correctly criticized Apple’s two alleged motivations to modify Lumidigm because neither provided a reason to use separate windows over each opening. Appx395.

The Commission added that Apple failed to show that the motivation needed to satisfy other limitations (adding a “convex surface” for “contact and comfort”) would remain if Lumidigm were modified to have multiple distinct openings and windows. Appx395-396. The Commission concluded Apple failed to present clear

and convincing evidence “that a POSITA *would have*” modified Lumidigm as Apple proposed. Appx396 (emphasis in original) (citing Appx126-129; Appx23710-23711; Appx24097-24099).

Apple also ignores the Commission’s explanation that its rejection of Apple’s Lumidigm-based obviousness theories was consistent with the Patent Office’s denial of Apple’s IPR petition that relied on Lumidigm “as the primary reference,” Appx396 (citing Appx23925-23946), and the “same modified version of Lumidigm,” Appx397. The Commission recognized that “[w]ithout the guidance provided by the claims of the ’502 patent, it is difficult to conclude that [Apple’s] postulation as to a particular structure that results from combining the teachings of Lumidigm [and the other prior art] is based on an objective assessment of what those teachings would have conveyed to a skilled artisan.” Appx397-398 (quoting Appx23941). The Commission recognized that Apple’s arguments were “grounded in hindsight rather than based on due consideration of the teachings of the pertinent prior art” and correctly rejected Apple’s feeble attempt to distinguish the Patent Office’s decision. Appx398 (quoting Appx23944). The Commission then applied that reasoning regarding Apple’s failure of proof to the various limitations reciting windows (or optically transparent material) extending across or within openings. Appx399-402.

The Commission’s decision does not violate *KSR Int’l Co. v. Teleflex Inc.*, 550 U.S. 398, 401 (2007), as Apple argues. Br. 52-53. Apple argues that its expert witness “testified—without contradiction—that Lumidigm’s face plate *could* be implemented as either (1) a single faceplate or (2) individual face plates over each opening.” Br. 52-53. But the Commission correctly explained the inadequacy of that testimony to the obviousness inquiry. Appx395; *see, e.g., Adidas AG v. Nike, Inc.*, 963 F.3d 1355, 1359 (Fed. Cir. 2020) (“The obviousness inquiry does not merely ask whether a skilled artisan *could* combine the references, but instead asks whether ‘they *would have been motivated to do so.*’”).

Moreover, Apple and its expert *never* presented the theory that “the evidence showed that *only* a small number of alternatives (two) were known in the art to solve the design problem of how to cover multiple openings.” Br. 53. While Apple’s expert identified two possible implementations of faceplates, he never said those were the *only* alternatives known in the art. Appx41318-41319(1221:16-1222:25). Thus, Masimo and its expert had no occasion to contradict or “dispute that only a limited number of possible variations existed.” Br. 53. Indeed, Apple admits it never referenced *KSR* and its finite-alternatives argument before the ALJ.

Br. 46 n.16; *see* Appx17066-17067; Appx21576-21577; Appx22992-22997. Thus, Apple has waived this argument.<sup>9</sup>

Finally, Apple challenges the Commission’s affirmance on claim 22 of the ’502 Patent, arguing that neither the ALJ nor the Commission “substantively addressed” Apple’s expert’s testimony that it was well-known to place optically transparent material in each of the openings. Br. 54. But the Commission addressed that evidence and Apple’s arguments about it. *See* Appx392 (summarizing Warren testimony including Appx41290-41291 and Appx41318-41319). The Commission considered Apple’s arguments about that testimony and found them “unpersuasive.” Appx394 (affirming and adopting FID findings and conclusions at Appx126-129). As explained above, the Commission emphasized that Apple’s expert testified only about what a POSITA *could* do, not what a POSITA *would* do when modifying Lumidigm. Appx395.

**E. Substantial Evidence Supports The Commission’s Findings Rejecting Apple’s Written Description Defenses**

Compliance with the written description requirement presents a question of fact, and to overcome the presumption of validity, a party must set forth clear and convincing evidence. Appx414 (citing *Centocor Ortho Biotech, Inc. v. Abbott*

---

<sup>9</sup> Apple’s footnote shows that the Commission’s counsel and Masimo were correct to argue in response to Apple’s stay motion that Apple had waived this *KSR* argument. *See* Br. 46 n.16.

*Lab'ys*, 636 F.3d 1341, 1347 (Fed. Cir. 2011)). Apple's written description evidence consisted of only one conclusory sentence from its expert on each of the two issues it now challenges. Appx41343-41344. Apple cannot carry its burden with such conclusory expert opinion testimony. *See, e.g., WBIP, LLC v. Kohler Co.*, 829 F.3d 1317, 1338-39 (Fed. Cir. 2016) (expert testimony that "[t]here was not sufficient written description" was generic, conclusory, and "d[id] not rise to the level of clear and convincing evidence"); *Koito Mfg. Co. v. Turn-Key-Tech, LLC*, 381 F.3d 1142, 1155 (Fed. Cir. 2004) (finding "conclusory [expert] testimony" that ignored the specification's disclosure "insufficient to show failure of written description"). Thus, the Commission properly found that Apple failed to present clear and convincing evidence that the asserted claims lack written description.

**1. The Poeze Patents' Specification Expressly Links The Multiple LEDs, Four Photodiodes, Protrusions With "Openings" Or "Holes," And Opaque Materials**

Apple argues the "ALJ's decision (which the Commission adopted without modification) contained a sweeping, legal error that affected all relevant claims" in finding written description support "only by linking together unrelated elements from different embodiments." Br. 55. But Apple ignores that it only briefly mentioned this issue on page 98 of its 100-page petition for review. Appx23712. There, Apple presented a single unsupported sentence of argument: "While the ID identified various limitations dispersed throughout the specification, it erroneously

found that they belong to the same embodiment by citing to generic language providing that one embodiment can mix-and-match between different sensors.” *Id.* Apple waived the issue by failing to adequately raise it in its petition for review. *See, e.g., Broadcom*, 542 F.3d at 901 (finding argument waived where party failed to “specifically assert” it). Thus, it is understandable why the Commission did not mention Apple’s mix-and-match written-description theory in its opinion.

Apple now devotes three pages to argue the Commission’s decision contains a “sweeping legal error” even though written description is a factual inquiry. Apple never explains why the Commission could not find as a matter of fact that a POSITA would have found that the inventors had possession of the inventions and thus the specification supported the claims. Appx161-165.

Before the ALJ, Apple conceded that the specification discloses each of the claimed features, and disputed only whether the specification describes those features in a single embodiment. Appx21639-21643. Apple asked its expert, Warren, one leading question on this theory—whether a single embodiment exists with all the claim limitations. Appx161-162 (citing Appx41343-41344 (1246:24-1247:7)). Warren responded: “I can’t find a single embodiment.” Appx41344(1247:6). Apple presented no further evidence. Masimo responded, through its expert, that the patent specification expressly links the various sensor embodiments together. Appx41444-414446; Appx65267.

The Commission observed how Masimo's expert explained the specification teaches that the features described in various sensor embodiments, including those of Figures 1-3, 7A-7B, 13, and 14F-14I, can be implemented together in a sensor. Appx162-164 (citing '501 Patent (Appx485-596) at Figs. 3C, 7B, 13, 27:13-41, 26:25-26, 19:38-48, 33:37-39). The Commission also found the specification expressly linked the sensor features and embodiments together. Appx161-165. The Commission explained that "[t]he specification of the Poeze patents expressly states that Figure 3C and Figure 7B are *not distinct embodiments*." Appx164 (citing and quoting Appx584(26:25-26)). The Commission detailed how these linked embodiments disclosed the limitations at issue. Appx164-165. The Commission weighed the evidence and found that Apple had failed to carry its burden on this written description defense. *Id.*

Apple incorrectly assumes that the Commission found adequate written description only "by linking together *unrelated* elements from different embodiments." Br. 55. But as explained above, the Commission found that the elements and embodiments are related. Appx162-165. Thus, Apple's citation to *Novozymes* is inapplicable. The Commission did not rely on an "amalgam of disclosures plucked selectively from the [original] application." *Novozymes A/S v. Dupont Nutrition Biosciences APS*, 723 F.3d 1336, 1349 (Fed. Cir. 2013). Apple's reliance on *Flash-Control* is similarly misplaced. *Flash-Control, LLC v. Intel Corp.*



recognized that a patent owner may be able to rely on multiple embodiments if those embodiments are “linked together in the specification.” 2021 WL 2944592, at \*3-4 (Fed. Cir. July 14, 2021).

**2. The Specification Discloses Emitters Each With An Identical Set Of LEDs**

Apple’s second written-description argument rests on the dissent by one Commissioner and applies only to claim 28 of the ’502 Patent and claim 12 of the ’648 Patent. Br. 58. Again, Apple presented inadequate evidence.

The Commission reversed the ALJ and found that “Apple did not meet its burden of proof because it relied on conclusory expert witness testimony and then on attorney argument alone to explain why [Masimo’s] citations to the specification did not provide written description support.” Appx420 (citing Appx22092). The Commission also found that the specification and Masimo’s expert testimony tended to show that the disputed limitations have written description support. *Id.*

To support its conclusion, the Commission quoted the testimony of Apple’s expert from Apple’s single leading question on the topic:

Q. Have you identified any discussion in the Poeze specification of the use of multiple sets of LEDs each with LEDs emitting at a first wavelength and a second wavelength?

A. I have not found one, no.

*Id.* (citing Appx41344(1247:14-17)). The Commission found that “Apple’s expert’s testimony is conclusory.” *Id.* Because of the conclusory nature of this testimony,

the Commission properly distinguished the ALJ's reliance on *Purdue Pharma L.P. v. Faulding Inc.*, 230 F.3d 1320, 1325 (Fed. Cir. 2000), "where the trial judge relied on extensive expert testimony and other prior art documents." Appx420-421.

The Commission then looked to the specification, particularly Figures 7A and 7B, which show "two emitters or two LEDs, each labeled 104." Appx421. The Commission explained that "[t]he fact that the LEDs and the emitters share the number (104) across the two figures[] suggests that they are the same (*i.e.*, both can include sets of LEDs)." *Id.* (citing '501 Patent, Appx578(13:16-21)). The Commission further reasoned that "within Figure 7A, the two LEDs share the same label 'LEDs 104,' and within Figure 7B, the two emitters share the same label 'Emitters 104,'" which "suggests that the two LEDs in Figure 7A are the same, and the two emitters in Figure 7B are the same." Appx421-422. This Commission's finding is consistent with 37 C.F.R. § 1.84(p)(4), which states that "the same reference character must never be used to designate different parts."

Continuing its analysis, the Commission explained a specification embodiment teaching that "the emitter 104 includes sets of optical sources that are capable of emitting visible and near-infrared optical radiation." Appx422 (citing '501 Patent, Appx576-578(12:9-12, 9:60-63, 13:16-21); Appx41446-41447 (1349:7-1350:3)). Based on these disclosures, the Commission concluded that "[i]f the two sets of LEDs or the two emitters have sets of optical sources are the same,

then they must emit the same visible and near-infrared optical radiation, *i.e.*, at the same two respective wavelengths.” Appx422; *see also* Appx423-424 (citing ’501 Patent, Appx577(12:38-40); Appx24377-24383). The Commission repeatedly determined this evidence confirms its finding that Apple had not shown by clear and convincing evidence that the relevant claims are invalid for lacking written description support. Appx422-424.

Apple argues that “nothing in the specification states that emitters 104 must be identical.” Br. 58. But Apple bore the burden to show that emitters 104 must be different. The Commission correctly found that even if the disclosure “*could be* interpreted” to encompass sets of LEDs with different wavelengths, that “does not mean that this is how a skilled artisan would understand the disclosure, especially when there is no testimony to this effect.” Appx422-423 (emphasis in original).

Finally, Apple ignores that in IPRs challenging Masimo’s patents, Apple admitted that “[e]ach set of LEDs includes multiple LEDs, as was *well known in the art*, with each set including LEDs with *the same* variety of wavelengths, *e.g.*, with *the same* three wavelengths ...” Appx25081; Appx24967-24968; *see, e.g., Hybritech Inc. v. Monoclonal Antibodies, Inc.*, 802 F.2d 1367, 1384 (Fed. Cir. 1986) (“a patent need not teach, and preferably omits, what is well known in the art.”).

**F. The Commission Correctly Construed The Claims To Find Infringement Of Every Asserted Poeze Patent Claim**

The ALJ correctly concluded that Apple literally infringes every asserted claim of the Poeze Patents. Appx31-60. The ALJ thoroughly explained the reasons for rejecting Apple’s flawed constructions of “over”/“above” (Appx31-35) and “openings”/“through holes” (Appx35-38).

**1. The Commission Correctly Construed “Over”/“Above” To Find Infringement Of Every Asserted Poeze Patent Claim**

Apple argues it cannot infringe because its Watches are “configured to” measure oxygen saturation only when “facing up,” “i.e., when the alleged protrusion (the back crystal) is under or below the photodiodes.” Br. 60-61.<sup>10</sup> Apple continues, advocating for a construction of “over” and “above” to mean that “the protrusion is spatially positioned on top of or higher than the photodiodes” with respect to Earth’s gravity. Br. 61. The ALJ correctly rejected Apple’s arguments, finding that “over” and “above” “do not require a vertical arrangement of features in a particular orientation.” Appx35; *see also* Appx41.<sup>11</sup>

Apple argues that “[t]he only evidence the ALJ relied on for her novel construction of ‘over,’” and “above” were “strained extrinsic analogies.” Br. 61-62.

---

<sup>10</sup> While Apple challenges infringement, it did not identify infringement as an issue for appeal in its stay motion before this Court. Dkt. 6.

<sup>11</sup> The ALJ conducted a *Markman* hearing, but none of the claim limitations at issue in this appeal were presented at that hearing. *See* Appx10077-10081.

## CONFIDENTIAL MATERIAL REDACTED

But Apple ignores most of the findings that support the ALJ’s construction. The ALJ properly considered intrinsic evidence in construing these terms. Appx32-35. For example, the ALJ found “an example in one embodiment of a material described as ‘over’ the glass layer when it is depicted as below that layer in Figure 7A.” Appx32 (citing ’501 Patent, Appx585(27:59-62); Appx522(Fig. 7A)). The ALJ also noted numerous examples that “describe[] a variety of measurement sites without reference to any specific orientation.” *Id.* (citing ’501 Patent, Appx575-577 (8:21-23, 10:15-27, 10:62-11:3, 11:45-55)).

The ALJ also considered extrinsic evidence in addition to the explanation from Masimo’s expert about a “bandage over a wound” and her own explanation of a “mask over one’s mouth.” Appx34. The ALJ identified multiple *Apple* patents and publications, among others, using the terms “over” and “above” in a manner consistent with their plain and ordinary meaning: Appx32-33 (citing Appx51682(32:17-23); Appx51684(35:38-55); Appx51400 ¶ 0065; Appx60454 (¶44); Appx70470 (9:51-56)). A named inventor admitted one such publication is “**APPLE CBI**” to Apple Watch. Appx52644(111:15-111:21) (discussing Appx51400 ¶ 0065).

Without addressing this evidence, Apple criticizes the bandage and mask examples and argues that “the relevant claims address the *absence of material*,” not “tangible objects.” Br. 61-62 (emphasis in original). But each claim recites tangible

objects—a device with various structures—as being over or above. For example, claims 24 and 30 of the '648 Patent recite “each through hole including a window and arranged over a different one of the at least four photodiodes.” Claim 28 of the '502 Patent recites “a protrusion arranged above the interior surface.” The ALJ thus correctly found that “‘over’ and ‘above’ have their plain and ordinary meaning and do not require a vertical arrangement of features in a particular orientation.” Appx35.

**2. The ID Correctly Construed “Through Holes” And “Openings” Through The Protrusion To Find Infringement Of Every Asserted Poeze Patent Claim**

Apple argues the Apple Watch cannot satisfy the “through holes” and “openings” limitations based on Apple’s construction that “through holes” and openings ... through” cannot contain any material. Br. 62. But Apple ignores the ALJ’s reliance on the Poeze Patents’ specification and claims to support the constructions. The ALJ found “[t]he specification explicitly provides that ‘[t]he openings can be made from glass to allow attenuated light from a measurement site, such as the finger, to pass through to one or more detectors.’” Appx37 (quoting '501 Patent, Appx575(8:26-30)); *see* Appx35-37 (citing '501 Patent, Appx581 (19:38-48); Appx585(27:13-32); Appx523(Fig. 7B)); '502 Patent, claims 19, 28; '648 Patent, claims 8, 20). Apple shows no error in that analysis.

Apple now relies on a dictionary definition of “through” and an example, neither of which Apple presented to the ALJ or Commission. Br. 62. But that dictionary and example do not show any error in the ALJ’s analysis. The ALJ explained the specification’s teaching that “openings can be made from glass to allow attenuated *light* from a measurement site, such as the finger, to pass through to one or more detectors.” Appx37 (quoting ’501 Patent, Appx575(8:26-30)). Within the meaning of Apple’s new “through” definition, *light* is the “something moving from one end of something to the other.” Apple also argues that “an opening through the roof ... would suggest that the interior of the house is open to the elements” seemingly referring to the passage of air or rain. Br. 62. But as the ALJ explained, the specification contradicts Apple’s “open to the elements” example by describing “conductive glass that ‘can be provided in the openings.’” Appx38 (quoting ’501 Patent, Appx585(27:20-22)). Apple therefore shows no error in the ALJ’s well-reasoned finding “that the claimed ‘openings’ and ‘through holes’ can contain transparent material.” Appx38.

**G. The Commission Did Not Abuse Its Discretion In Rejecting Apple’s Prosecution Laches Defense**

**1. Apple Waived Its Prosecution Laches Defense**

Apple waived its prosecution laches defense by failing to adequately present it in its petition for review. Apple’s petition contained only a single, broadly written paragraph alleging the ALJ erred with no explanation. Appx23713-23714. And

Apple devotes only a footnote (Br. 67 n.18) to address the Commission's holding that Apple waived the defense by not adequately raising it in its petition for review as required by Commission rule. Appx27235-27237 (denying Apple's stay motion, citing 19 C.F.R. § 210.43(b)(2)).

Under that rule, any "petition for review must set forth a concise statement of the facts material to the consideration of the stated issues, and must present a concise argument providing the reasons that review by the Commission is necessary or appropriate to resolve an important issue of fact, law, or policy." 19 C.F.R. § 210.43(b)(2). "Petitions for review may not incorporate statements, issues, or arguments by reference." *Id.* Finally, "[a]ny issue not raised in the petition for review will be deemed to have been abandoned by the petitioning party and may be disregarded by the Commission." *Id.*

Because Apple violated this rule, the Commission had no opportunity to address any Apple argument criticizing the ALJ's rejection of Apple's laches defense, and Masimo had nothing to respond to. And the Commission explained why Apple violated the rule and thus waived that defense. Appx27235-27237. Apple's petition merely incorporated its initial post-hearing brief by reference, which was "not sufficient to raise the issue before the Commission." Appx27236; *see* Appx23713-23714. Thus, Apple waived this defense. *Philip Morris*, 63 F.4th at 1336-1337 (affirming waiver where party failed to preserve issue in petition for



review and raised it later in a motion to stay); *see also Finnigan*, 180 F.3d at 1363; *Guangdong Alison Hi-Tech Co. v. Int’l Trade Comm’n*, 936 F.3d 1353, 1362 (Fed. Cir. 2019).

Apple’s footnote argues that this Court “cannot rely on” the Commission’s waiver finding because the Commission made that finding in its order denying Apple’s stay motion—rather than in its Opinion. Br. 67 n.18 (citing Appx27236-27237). But Apple ignores that its arguments would circumvent Rule 210.43(b)(2) and this Court’s caselaw.

Regardless of the Commission’s later waiver explanation, Apple failed to preserve prosecution laches for appeal. Apple argues that it preserved this defense because it “*did* raise the issue in its petition.” Br. 67 n.18 (emphasis in original). But Apple merely cites to the same two conclusory sentences that violate the Commission rule set forth above. Simply mentioning the defense is not preserving it for appeal.

**2. Apple Cannot Show The Commission Abused Its Discretion In Rejecting Apple’s Prosecution Laches Defense**

Even if Apple had preserved prosecution laches, Apple cannot show the Commission abused its discretion by rejecting the defense on the merits. Appx177-179. Apple bore the burden of establishing (1) “unreasonable and unexplained delay in prosecution” and (2) prejudice. *Cancer Rsch. Tech. Ltd. v.*

*Barr Lab 'ys, Inc.*, 625 F.3d 724, 728-29 (Fed. Cir. 2010). The Commission rejected the defense because Apple did not show any delay by Masimo. Appx177-179.

First, Apple points to a twelve-year period between Masimo's filing of the 2008 provisional applications and Masimo's September 2020 filings of the applications leading to the asserted patents. Br. 63. Apple argues that there is no reason for the twelve-year period "other than strategic gamesmanship." *Id.* The Commission rejected that theory. Appx177-178. The Commission relied on the unrebutted testimony from a former USPTO Commissioner for Patents, explaining Masimo's "continuous unbroken chain of patent prosecution" and "no delay." Appx41512(1415:2-10). Masimo's patent lawyer explained there was no delay because there were "over 30 applications or continuations filed and actively prosecuted" during the twelve-year period. Appx41132(1036:6-18); *see also* Appx178 n.64 (citing Appx58279-59360); Appx57665-58278; Appx59361-60003 (prosecution histories of parent applications showing activity from 2009 through 2019). Apple presented no testimony or evidence to show Masimo delayed any prosecution.

Apple's reliance on a five-year period from July 2010 to December 2015 incorrectly assumes that continuous prosecution must occur "in the chain" of applications. Br. 63. The Commission rejected this argument, citing testimony from Masimo's patent lawyer that there was "continuous prosecution activity in the family

of the Poeze patents during this time.” Appx177-178 (citing Appx41134(1038:7-19)); *see also* Appx41135(1039:7-19) (explaining there were “a dozen applications being actively prosecuted” in the patent family during five-year period).

Apple cites *Sonos* to dismiss any reliance on Masimo’s continued prosecution. Br. 66 (citing *Sonos, Inc. v. Google LLC*, 2023 WL 6542320 (N.D. Cal. Oct. 6, 2023), *appeal docketed*, No. 24-1097 (Fed. Cir. Oct. 30, 2023)). But Apple ignores the facts in *Sonos*. There, the court identified specific acts supporting unreasonable and unexplained delay, such as repeatedly delaying the issuance of allowed claims, *id.* at \*26 n.11, adding new matter while hiding that fact from the Patent Office and the district court, *id.* at \*18, \*24-25, and adding that new matter after seeing the defendant’s confidential product plans, *id.* at \*11. Apple presents no similar facts here.

Apple speculates that Masimo’s patent filings “track the launches of subsequent Apple releases” and that the “only apparent explanation is that Masimo intended to draft the claims only after reviewing Apple’s products.” Br. 64. But the Commission rejected this speculation, finding that “Apple has *not* provided evidence showing that newly asserted claim limitations were specifically drawn to the Accused Products.” Appx179 n.65.

Apple also criticizes Masimo for failing to explain “why the patent applications were not filed earlier.” Br. 64. The Commission explained that being

able to file earlier is not a sufficient basis to find prosecution laches and cited this Court's precedent that "[t]here are legitimate grounds for refiling a patent application which should not normally be grounds for a holding of laches, and ... [t]he doctrine should be applied only in egregious cases of misuse of the statutory patent system." Appx178 (citing *Symbol Techs., Inc. v. Lemelson Med., Educ. & Rsch. Found.*, 422 F.3d 1378, 1385 (Fed. Cir. 2005)). The Commission found Apple "failed to identify actions by Masimo that resemble the type of conduct recognized by the Federal Circuit as unjustifiable prosecution delay." Appx178-179.

Apple argues that Masimo's conduct is analogous to the activity in *Hyatt v. Hirshfeld*, 998 F.3d 1347, 1357 (Fed. Cir. 2021), and *Symbol Techs., Inc.*, 422 F.3d at 1386. Br. 65-66. But the Commission correctly distinguished those cases. Appx178-179. Each of those cases involved extraordinary facts delaying the issuance of numerous pre-GATT applications. Apple also relies on *In re Bogese*, 303 F.3d 1362, 1369 (Fed. Cir. 2002). Br. 65. But that case is distinguishable for the same reasons cited by the Commission. Appx178-179. Moreover, Masimo's patents were filed post-GATT and were prosecuted publicly since 2010. *See* Appx51811.

With regard to Apple's reliance on *Hynix*, Br. 65, in that case the district court did not find laches, but merely denied summary judgment of no prosecution laches.

*Hynix Semiconductor Inc. v. Rambus Inc.*, 2007 WL 4209386, at \*5 (N.D. Cal. Nov. 26, 2007).

Regarding prejudice, Apple misleadingly argues that the Commission “*did not deny*” that Apple suffered significant prejudice due to Masimo’s misconduct.” Br. 66. But the Commission never reached prejudice because no evidence suggested any delay. *See* Appx177-179. Thus, Apple’s reliance on *Personalized Media Commc’ns, LLC v. Apple Inc.*, 57 F.4th 1346, 1354 (Fed. Cir. 2023), is misplaced. Br. 66-67. Apple cannot properly urge this Court to make findings about any prejudice in the first instance.

## VI. CONCLUSION

For the above reasons, this Court should affirm the Commission’s decision in all respects.

KNOBBE, MARTENS, OLSON & BEAR, LLP

Dated: June 28, 2024

By: /s/ Joseph R. Re

Joseph R. Re  
Stephen C. Jensen  
Sheila N. Swaroop  
Jonathan E. Bachand  
Brian C. Claassen

*Counsel for Intervenors  
Masimo Corporation and  
Cercacor Laboratories, Inc.*

**CERTIFICATE OF COMPLIANCE**

1. This brief complies with the type-volume limitation of Federal Rule of Appellate Procedure 27(d)(2). This brief contains 13,712 words, excluding the parts of the brief exempt by Federal Rule of Appellate Procedure 32(b) and Federal Circuit Rule 32(b)(2).

2. This brief complies with the typeface requirements of Federal Rule of Appellate Procedure 32(a)(5) and the type style requirements of Federal Rule of Appellate Procedure 32(a)(6). This brief has been prepared in a proportionally spaced typeface using Microsoft Word in 14 point font Times New Roman.

KNOBBE, MARTENS, OLSON & BEAR, LLP

Dated: June 28, 2024

By: /s/ Joseph R. Re  
Joseph R. Re

*Counsel for Intervenors  
Masimo Corporation and  
Cercacor Laboratories, Inc.*

**CERTIFICATE OF CONFIDENTIAL MATERIAL**

1. This brief marks as confidential fourteen (14) unique words (including numbers), excluding confidential material pursuant to Fed. Cir. R. 25.1(d)(1)(C).
2. This number does not exceed the maximum number of fifteen (15) words permitted by Fed. Cir. R. 25.1(d)(1)(A).

KNOBBE, MARTENS, OLSON & BEAR, LLP

Dated: June 28, 2024

By: /s/ Joseph R. Re

Joseph R. Re

*Counsel for Intervenors  
Masimo Corporation and  
Cercacor Laboratories, Inc.*