

United States Court of Appeals for the Federal Circuit

LUV N' CARE, LTD.,
Plaintiff-Appellant

NOURI E. HAKIM,
Counter-Defendant-Appellant

v.

LINDSEY LAURAIN,
Defendant

EAZY-PZ, LLC,
Defendant/Counter-Claimant-Cross-Appellant

2022-1905, 2022-1970

Appeals from the United States District Court for the Western District of Louisiana in No. 3:16-cv-00777-TAD-JPM, Judge Terry A. Doughty.

Decided: April 12, 2024

CAROL WELBORN REISMAN, Liskow & Lewis, New Orleans, LA, argued for appellants. Also represented by GEORGE DENEGRÉ, JR., MELANIE DEREFINCO, CAREY MENASCO; HARTWELL POWELL MORSE, III, Luv n' Care, Ltd., Monroe, LA.

JENNIFER KROELL FISCHER, Fischer Law Firm, PC, Denver, CO, argued for defendant/counter-claimant-cross-appellant.

Before REYNA, HUGHES, and STARK, *Circuit Judges*.

STARK, *Circuit Judge*.

This appeal arises from a lawsuit between two manufacturers of dining mats for toddlers: Luv n' care, Ltd. and Nouri E. Hakim (collectively, "LNC"), on one side, and Lindsey Laurain ("Laurain") and Eazy-PZ, LLC (collectively, "EZPZ"), on the other. After years of litigation, a judge in the United States District Court for the Western District of Louisiana ("Western District") held a bench trial. The trial court then issued an opinion finding that LNC failed to prove EZPZ's U.S. Patent No. 9,462,903 (the "903 patent") is unenforceable due to inequitable conduct but, at the same time, LNC succeeded in proving that EZPZ was barred from obtaining relief due to its "unclean hands." Separately, the district court granted LNC's motion for partial summary judgment that the claims of the '903 patent are invalid as obvious. The court also denied LNC's motion to recover its attorney fees and costs.

Both LNC and EZPZ now appeal. As explained below, we (1) affirm the district court's judgment for LNC on unclean hands; (2) vacate the judgment for EZPZ of no inequitable conduct; (3) vacate the grant of partial summary judgment of invalidity; and (4) vacate the orders denying attorney fees and costs. We remand for further proceedings consistent with this opinion.

I

A

Many parents have experienced the "inconvenience of having to clean up after their children's mealtimes," especially when those meals involve their children "dislodging

and upturning their plates and bowls to spill foodstuffs and beverages everywhere.” ’903 patent at 1:54-58. The ’903 patent provides a solution to this problem by introducing a surface contact self-sealing dining mat integrated with tableware, thereby preventing the separation of tableware from the dining mat, while also preventing the lateral displacement and overturning of the dining mat. *See id.* at 1:59-64. An exemplary dining mat is depicted in Figure 1 of the ’903 patent, reproduced below.

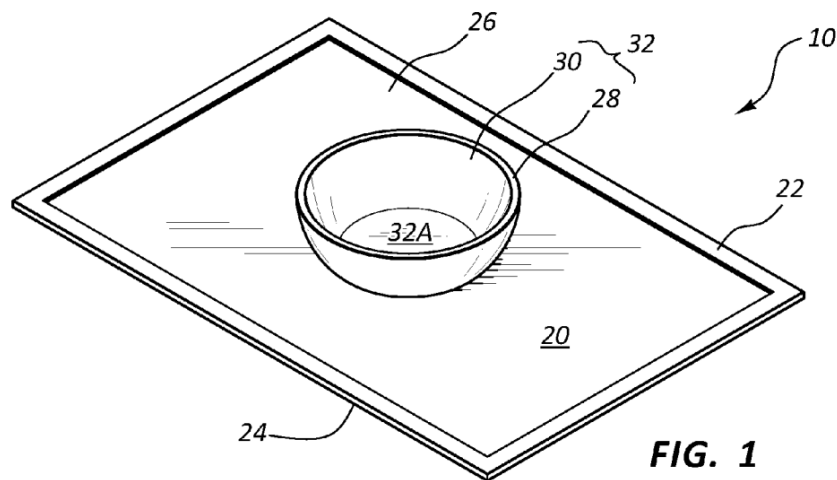

FIG. 1

The dining mat features “a planar portion . . . for sealable contact upon an underlying surface, wherein lateral displacement . . . is preventable.” *Id.* at 1:66-2:2. “[A] partial vacuum” is created “between the planar portion and [the] underlying surface when attempts to lift the planar portion away from [the] underlying surface are effected.” *Id.* at 2:2-5. This “partial vacuum” “prevents separation of the planar portion from the underlying surface except when [the] planar portion is first peeled away . . . at an outer edge of [the] planar portion.” *Id.* at 2:5-8. The upper surface of the mat “includes a raised perimeter . . . defining

a concavity [which] is contemplated to include at least one receptacle wherein foodstuffs are storable, as desired, for ingestion therefrom.” *Id.* at 2:41-45.

The '903 patent contains nine claims. Claims 1, 5, and 9 are independent claims. Claim 1 recites:

1. A surface contact self-sealing integrated tableware and dining mat comprising a rubberlike planar portion having a raised perimeter delimiting at least one concavity surrounding at least one receptacle above an upper surface and an entirely suffuse undersurface disposed for sealable contact with an underlying surface upon which said mat is disposed, said sealable contact preventative of lateral displacement of the planar portion across the underlying surface, wherein said sealable contact creates a partial vacuum when attempts to separate the undersurface from the underlying surface are made except at an outer edge of the planar portion, whereby removal of the planar portion from the underlying surface is effective only by peeling the undersurface from the underlying surface starting first at the outer edge.

Id. at 5:17-30.

Claim 5 recites:

5. A surface contact self-sealing integrated tableware and dining mat comprising:
a nontoxic polymeric planar portion;
an outer edge parametrically bounding said planar portion;
an undersurface entirely suffuse upon the planar portion, said undersurface disposed to

sealably contact an underlying surface upon which the planar portion is disposed;

an upper surface; and

a raised perimeter disposed within the upper surface, said raised perimeter defining a concavity wrought above the upper surface of the planar portion to delimit at least one receptacle upon the planar portion;

wherein the undersurface sealably contacts an underlying surface upon which the planar portion is disposed, said undersurface thereby preventing lateral displacement of the planar portion upon said underlying surface by frictional engagement therewith and, further, creation of a partial vacuum between the undersurface and the underlying surface when attempt is made to remove said planar portion away from said underlying surface, whereby foodstuffs are positional interior to the at least one receptacle, said receptacle thence maintained in desired position by action of the planar portion contacting said underlying surface, and removal of said planar portion from said underlying surface is effective only when said planar portion is lifted from said underlying surface first at the outer edge of the planar portion.

Id. at 5:42-6:14.

Claim 9 is identical to claim 5 except in two respects. First, instead of a “nontoxic polymeric planar portion,” claim 9 specifically recites a “silicone planar portion.” *Id.* at 6:29. Second, the final “wherein” clause of claim 9, as shown below, has several limitations that are different from that of claim 5:

wherein the undersurface sealably contacts an underlying surface upon which the planar portion is disposed, said undersurface thereby preventing lateral displacement of the planar portion upon said underlying surface by frictional engagement therewith and, further, creation of a partial vacuum between the undersurface and the underlying surface when attempt is made to separate said planar portion from said underlying surface, whereby foodstuffs are *selectively* positional interior to the at least one receptacle, said receptacle thence maintained in desired position *upon the underlying surface* by action of the planar portion contacting said underlying surface, and removal of said planar portion from said underlying surface is effective only when said planar portion is *separated* from said underlying surface first at the outer edge of the planar portion.

Id. at 6:41-56 (emphasis added).

B

In June 2016, LNC filed a complaint in the Western District against EZPZ, seeking injunctive and monetary relief due to EZPZ's alleged "acts of unfair competition." J.A. 481. LNC's claims were brought pursuant to the Lanham Act, 15 U.S.C. § 1125(a), and the Louisiana Unfair Trade Practices and Consumer Protection Law ("LUTPA"), La. Rev. Stat. § 51:1401 *et seq.* LNC also sought a declaratory judgment that EZPZ's U.S. Design Patent No. D745,327 (the "327 design patent") is invalid, unenforceable, and not infringed.

On October 11, 2016, the United States Patent and Trademark Office ("PTO") issued the '903 patent to Ms. Laurain, who assigned her rights to EZPZ. LNC filed an amended complaint, adding to its declaratory judgment

claim a request that the '903 patent be declared invalid, unenforceable, and not infringed. In November 2016 and January 2017, EZPZ filed counterclaims against LNC, including for infringement of the '327 design patent and the '903 patent, as well as copyright, trademark, and trade dress infringement, violation of LUTPA, and unjust enrichment.

Following discovery, LNC moved for partial summary judgment on the basis that the claims of the '903 patent are invalid. The district court granted LNC's motion in May 2020, finding that all claims of the '903 patent are obvious over U.S. Patent Publication No. 2003/0152736 ("Bass") in view of U.S. Patent Publication No. 2008/0245947 ("Webb Publication") and U.S. Patent No. 8,251,340 ("Webb Patent"). We will refer to the Webb Publication and Webb Patent together as the "Webb Prior Art."

Bass discloses "a plate mat for use in restaurants and homes," having "an adhesive backing so it can be securely affixed to a table top or tray." J.A. 1085. Bass also teaches an "enclosed space" integrated with "[t]he upper surface of the mat." *Id.* The Webb Publication discloses a mat "arranged to grip a support surface on which the mat portion is laid, in use, by formation of at least a partial vacuum between the mat portion and the support surface upon deformation of the mat portion." J.A. 1088. The district court did not separately discuss the Webb Patent, observing that "[t]he Webb Publication and Webb Patent . . . generally share the same specification." J.A. 8.

The district court acknowledged that "Bass does not disclose or specify a material for its integrated tableware and dining mat," but found it would have been "common sense to a person of ordinary skill in the art" to make "the integrated tableware and dining mat disclosed in Bass out of the rubberlike, nontoxic material disclosed in the Webb Publication." J.A. 16, 19 (internal quotation marks omitted). The court further found that "the showing of

obviousness in this case is compelling and is not called into doubt by the evidence of secondary considerations.” J.A. 27.

In June 2020, EZPZ moved for reconsideration of the district court’s summary judgment ruling. The district court denied the motion in October 2020, indicating that “[a] [r]uling providing further reasoning will follow in due course.” J.A. 2637. Before any such ruling was issued, EZPZ requested *ex parte* reexamination of its ’903 patent by the PTO. On August 5, 2021, EZPZ notified the district court that it had been advised by the PTO that the agency would soon issue an *ex parte* reexamination certificate confirming the patentability of the ’903 patent’s claims. The PTO issued such a certificate on August 23, 2021, but EZPZ did not provide it to the district court before or during the bench trial that began on August 25, 2021.

Hence, during the bench trial, the district judge knew that a reexamination certificate – reiterating the PTO’s view that the claims of the ’903 patent were nonobvious – would be forthcoming, but he did not have the certificate in his record. The trial, which ultimately ran to eight days, concerned only the issues of (i) whether inequitable conduct (which LNC had asserted as both a declaratory judgment claim and an affirmative defense) had been committed in connection with prosecution of the ’903 patent, and (ii) whether EZPZ’s conduct during the litigation had amounted to unclean hands (which LNC had asserted as an affirmative defense).

On December 21, 2021, the district court issued its post-trial opinion. In it, the court held that LNC did not meet its burden of proving that the ’903 patent is unenforceable due to inequitable conduct. Specifically, the district court found that although Ms. Laurain and her patent agent, Benjamin Williams (“Williams”), made misrepresentations to the PTO – namely, that the prior art Platinum Pets mat did not exhibit self-sealing functionality – that

misrepresentation was not but-for material to the patentability of the '903 patent, given that the Platinum Pets mat itself had been disclosed to the PTO. The district court further found that several other prior art references Ms. Laurain and Mr. Williams withheld from the PTO were also not material because they were cumulative of the Platinum Pets mat. Additionally, the court found that Ms. Laurain's and Mr. Williams' misrepresentation of the Platinum Pets mat, as well as their submission of declarations containing false or misleading information, did not demonstrate a specific intent to deceive the PTO.

Turning to LNC's unclean hands defense, the district court determined that unclean hands barred EZPZ from obtaining relief on its then-remaining counterclaims. In particular, the court found that EZPZ engaged in litigation misconduct, including by failing to disclose certain patent applications during discovery, attempting repeatedly to block LNC from obtaining Ms. Laurain's prior art searches, stringing LNC along during settlement negotiations, and providing evasive and misleading testimony. The court concluded that EZPZ "by deceit and reprehensible conduct attempted to gain an unfair advantage" and, thus, "is not entitled to the relief it seeks." J.A. 189-90.

On the same day it issued its bench trial opinion, the district court provided the parties with its follow-up reasoning for having denied EZPZ's motion for reconsideration of its grant of summary judgment of obviousness. In doing so, the court observed: "[g]iven that the issues presented at the bench trial required a full understanding of the prior art and related evidence, the [c]ourt was provided with the opportunity to gain a better understanding of this evidence as it relates to EZPZ's motion for reconsideration." The district court held that the challenged claims were invalid as obvious over the combination of Bass and the Webb Prior Art – the same grounds on which it had relied in the original summary judgment opinion – and were also obvious over a new combination consisting of Bass and the Tommee

Tippee mat, the latter of which was described by the court as “a commercial embodiment of the Webb Prior Art.” J.A. 35 n.4.

After the district court entered judgment, EZPZ moved for amendment of the court’s findings of fact, conclusions of law, and judgment relating to LNC’s unclean hands defense. EZPZ argued that the court erred in considering certain facts relating to EZPZ’s litigation misconduct and that it also lacked the requisite analysis of how EZPZ’s actions had a necessary and immediate connection to the relief EZPZ was seeking from the court. EZPZ also again sought reconsideration of the grant of summary judgment of obviousness, this time based on the PTO’s issuance of the *ex parte* reexamination certificate, which EZPZ provided to the district court only after the entry of judgment.

The district court ruled on the motion relating to unclean hands on June 9, 2022, granting it in part and denying it in part and then issuing an amended bench trial opinion. The court explained that it would, as EZPZ requested, exclude from consideration certain facts – including those relating to EZPZ’s deposition and trial testimony and its conduct during settlement negotiations – in connection with its evaluation of LNC’s unclean hands defense. In its amended opinion, the court also, for the first time, expressly addressed the issue of the necessary and immediate connection between EZPZ’s unclean hands and the relief EZPZ was seeking from the court. Based on its revised analysis, the court continued to find that unclean hands barred EZPZ from obtaining relief on its counterclaims.

On the same day, the district court granted in part and denied in part EZPZ’s motion directed to its summary judgment ruling on obviousness. The court acknowledged that the reexamination certificate was “evidence that it did not have before it prior to the [o]bviousness [r]uling or in briefing on reconsideration.” J.A. 197. Still, after reviewing the

prosecution history, including the reexamination, the court was “not persuaded that it requires or compels altering or amending the [c]ourt ruling that the ’903 Patent is invalid.” *Id.* The district court also denied LNC’s motion for attorney fees and its request for costs.

The timely appeal and cross-appeal followed. We have jurisdiction under 28 U.S.C. § 1295(a)(1).

II

LNC’s appeal and EZPZ’s cross-appeal together raise a multitude of issues. We will address them in the following order: (1) EZPZ’s appeal of the determination that the doctrine of unclean hands bars EZPZ from obtaining relief on its claims; (2) LNC’s appeal of the court’s conclusion that it failed to prove the ’903 patent is unenforceable due to inequitable conduct; (3) EZPZ’s appeal of the grant of summary judgment that the claims of the ’903 patent are invalid as obvious; and (4) LNC’s appeal of the district court’s denial of an award of attorney fees and costs.

A

We begin with EZPZ’s contention that the district court erred in finding that the doctrine of unclean hands bars EZPZ from obtaining its requested relief. We disagree with EZPZ and affirm the district court.

A court may find unclean hands when the misconduct of a party seeking relief “has immediate and necessary relation to the equity that he seeks in respect of the matter in litigation . . . for such violations of conscience as in some measure affect the equitable relations between the parties in respect of something brought before the court for adjudication.” *Keystone Driller Co. v. Gen. Excavator Co.*, 290 U.S. 240, 245 (1933). “We review the district court’s ruling [of unclean hands] for abuse of discretion, which means that we review factual findings only for clear error.” *Gilead Scis., Inc. v. Merck & Co.*, 888 F.3d 1231, 1240 (Fed. Cir. 2018). We review “the totality of the evidence-supported

misconduct [and] not individual elements alone.” *Id.* We may affirm on any grounds that are adequately supported by the evidence in the record and are not limited to those bases for unclean hands expressly relied on by the district court. *See Jaffke v. Dunham*, 352 U.S. 280, 281 (1957) (“A successful party in the District Court may sustain its judgment on any ground that finds support in the record.”); *Rexnord Indus., LLC v. Kappos*, 705 F.3d 1347, 1356 (Fed. Cir. 2013) (“On judicial review, the correctness of the decision appealed from can be defended by the *appellee* on any ground that is supported by the record.”).

In finding unclean hands, the district court thoroughly analyzed EZPZ’s misconduct. For example, the district court found that EZPZ failed to disclose to LNC patent applications related to the ’903 patent until well after the close of fact discovery and dispositive motion practice, and in some cases, only when required by court order, all without any good faith justification for its delay. In particular, EZPZ failed to disclose U.S. Patent Application No. 15/700,403 (the “403 application”), the prosecution of which involved claim construction relevant to a disputed claim term also found in the ’903 patent.

The district court additionally found that EZPZ tried to block LNC’s efforts to discover Ms. Laurain’s prior art searches by falsely claiming she had conducted no such searches and that all responsive documents had been produced. It further found that EZPZ witnesses – including Ms. Laurain and Jordan Bolton, EZPZ’s former outside counsel – repeatedly gave purposefully evasive testimony during depositions and at trial. In particular, according to the district court, Ms. Laurain repeatedly provided false testimony that was directly contradicted by other contemporaneous evidence.

EZPZ argues on appeal that the record does not support the district court’s finding that the misconduct rose to the level of “unconscionable acts” or had the requisite

nexus to the '903 patent infringement claims the district court dismissed based on unclean hands. We are unpersuaded. Instead, we find no clear error in the district court's findings, which fully support its conclusion that EZPZ comes to the court with unclean hands.

The evidence in the record, including what we summarized just above, supports the district court's finding that EZPZ "by deceit and reprehensible conduct attempted to gain an unfair advantage" in seeking the relief it requested in the litigation. J.A. 324. The district court did not clearly err in finding this conduct to be "offensive to the integrity of the [c]ourt," resulting in the district court's "loss of confidence in [EZPZ's] candor." J.A. at 323-24.

Nor do we find clear error in the district court's determination that EZPZ's misconduct bears an immediate and necessary connection to EZPZ's claims for infringement of its '903 patent. The undisclosed patent applications and their prosecution are directly relevant to the development of LNC's litigation strategy. Because EZPZ only provided the '403 application to LNC after the claim construction phase of the litigation, EZPZ deprived both LNC and the district court of the opportunity to understand the PTO's construction of a claim term that was also of importance to this litigation.¹

¹ The claim term is "planar portion," which appears in all claims of the '903 patent. The district court construed it to mean "a part of an area relating to a plane," which largely tracked EZPZ's proposed construction ("a part that includes an area that relates to a plane"). J.A. 655, 659. The court rejected LNC's proposed construction of "plain and ordinary meaning of a flat surface. A flat surface is one that is not curved." J.A. 655. During the prosecution of the '403 application, the examiner rejected certain pending claims as indefinite. These claims included a limitation

EZPZ's failure to disclose the prior art searches undermined LNC's ability to press its invalidity and unenforceability challenges. There is no clear error in the district court's finding that Ms. Laurain's prior art searches may have supported LNC's contention that she had located the Webb Prior Art and other key references during her initial searches, well in advance of filing the application that led to the '903 patent. Likewise, what the district court found to be EZPZ witnesses' evasive and false testimony during depositions and at trial further deprived LNC of material information for consideration by its experts, for use in connection with dispositive motion practice, and as part of both its declaratory judgment claim and its defense against EZPZ's counterclaims. *See generally Gilead*, 888 F.3d at 1244 (holding that "intentional testimonial falsehoods" can qualify as misconduct supporting determination of unclean hands). In at least all of these ways, the record supports a finding of an "immediate and necessary" connection between EZPZ's misconduct and its '903 patent infringement claim, leaving the district court's finding on this point untainted by clear error.

"wherein the planar portion is cambered," and the examiner found a contradiction between "planar portion" and "cambered." J.A. 5792 (examiner explaining that "[b]y definition, [c]ambered means arched slightly or curved upward in the middle, and *planar means lying in a plane, or flat*") (emphasis added). Similarly, in rejecting other pending claims for indefiniteness, the examiner stated that "*the undersurface of the planar portion appears to be completely flat.*" J.A. 5792-93 (emphasis added). It was not clear error for the district court to conclude that LNC's claim construction argument may have been strengthened had it been provided, as it should have been, with this prosecution history of a related application.

EZPZ additionally contends that the district court failed to find any misconduct bearing a necessary and immediate connection to its design patent and trade dress claims. Hence, in its view, at least these two claims should not have been dismissed due to unclean hands. On this point, the district court explained:

[T]here is an “immediate and necessary relation” between the unclean hands findings and the dismissed claims. EZPZ’s design patent and trade dress infringement claims were pled at the outset, the subject of LNC’s written discovery, addressed at depositions and the subject of motion practice. After five years of litigation, EZPZ’s conduct with respect to its pursuit of the ’903 Patent infringement claim cannot be cordoned off from its conduct with respect to its pursuit of its other claims. For example, the Court’s finding that EZPZ knowingly deprived it of important information during claims construction cuts across all claims. The Court’s loss of confidence in a party’s candor cannot be overcome with respect to other theories of recovery.

J.A. 323 (internal citations omitted). We find no clear error in this analysis.

In sum, the district court did not clearly err in its assessment that the totality of the evidence demonstrated that EZPZ engaged in misconduct rising to the level of unconscionable acts, enhancing EZPZ’s litigation positions and undermining those of LNC, creating immediate and necessary connections between EZPZ’s misconduct and the relief it was seeking from the court. Thus, the district court did not abuse its discretion in finding that unclean hands barred EZPZ from seeking relief for alleged infringement of its ’903 patent, its ’327 design patent, or its trade dress.

We affirm the district court's judgment with respect to unclean hands.

B

We turn next to LNC's appeal from the district court's finding that it failed to prove the '903 patent is unenforceable due to inequitable conduct.

Inequitable conduct renders a patent unenforceable and is, therefore, an affirmative defense to an allegation of patent infringement. To prove inequitable conduct, a party must show that the patentee withheld material information from the PTO, and did so with the specific intent to deceive the PTO. *See Therasense, Inc. v. Becton, Dickinson & Co.*, 649 F.3d 1276, 1290 (Fed. Cir. 2011) (en banc). Both requirements must be proven by clear and convincing evidence. *See id.* at 1287. Moreover, deceptive intent must be the single most reasonable inference based on the evidence. *See id.* at 1290.

We review the district court's fact findings as to materiality and deceptive intent for clear error, *see Regeneron Pharms., Inc. v. Merus N.V.*, 864 F.3d 1343, 1351 (Fed. Cir. 2017), and its ultimate determination of inequitable conduct based on those findings of fact for an abuse of discretion, *see Energy Heating, LLC v. Heat On-The-Fly, LLC*, 889 F.3d 1291, 1299 (Fed. Cir. 2018).

The district court held that LNC failed to prove inequitable conduct by the requisite burden of proof. We vacate this portion of the district court's holding and remand for further proceedings.

1

We first address LNC's arguments on materiality. LNC contends that Ms. Laurain and Mr. Williams misrepresented the self-sealing functionality of the Platinum Pets mat to the PTO and that these misrepresentations are per se material. As we have previously explained, "in cases of

affirmative egregious misconduct,” materiality is established per se, without need to prove its impact on the PTO’s patentability determination. *Therasense*, 649 F.3d at 1292; see also *Aventis Pharma S.A. v. Hospira, Inc.*, 675 F.3d 1324, 1334 (Fed. Cir. 2012) (“[B]ut-for materiality is the standard for evaluating the materiality prong of the [inequitable conduct] analysis unless there is affirmative egregious misconduct.”). We are unable to discern from the district court’s trial opinion whether it made findings as to affirmative egregious misconduct and per se materiality. The district court’s analysis of those issues seems to have been embedded with its assessment of deceptive intent. Intent and materiality, however, are separate requirements, both of which must be proven to establish inequitable conduct. See *Therasense*, 649 F.3d at 1290. On remand, the district court should determine whether Ms. Laurain’s and Mr. Williams’ misrepresentation of the self-sealing functionality of the Platinum Pets mat amounted to affirmative egregious misconduct and is, therefore, per se material.

If the court finds there is no affirmative egregious misconduct, it must then reassess its prior determination that LNC failed to prove the misrepresentations to the Board were but-for material. An undisclosed prior art reference is but-for material “if the PTO would not have allowed a claim had it been aware of” the reference. *Id.* at 1291. The district court appears to have concluded that the Platinum Pets mat could not be found but-for material because it “was disclosed to” the PTO, and the PTO “had the opportunity to consider” it before granting the ’903 patent. J.A. 268. LNC points out, however, that the district court found Ms. Laurain and Mr. Williams “misrepresented the characteristics of the Platinum Pets [m]at” by describing it falsely to the PTO (i.e., as a prior art device that does not practice self-sealing) and by withholding a video showing that the mat “does in fact self-seal to an underlying surface.” J.A. 264-67. On remand, in connection with its evaluation of the totality of evidence before it, the district court

must evaluate whether the PTO's patentability decision may have differed if Ms. Laurain and Mr. Williams had described the Platinum Pets mat accurately and had disclosed the withheld video to the PTO. *See TransWeb, LLC v. 3M Innovative Proprs. Co.*, 812 F.3d 1295, 1304 (Fed. Cir. 2016) (holding that even disclosed reference may be but-for material where patentee mischaracterized it as non-prior art).

LNC argues that the district court also erred in finding several other prior art references Ms. Laurain and Mr. Williams failed to disclose to the PTO – the Hot Iron holster, the CIBO “Stick Anywhere” placemat, the Momo baby skid-proof silicone placemat, and the Brinware silicone placemat – were not material because they are cumulative of the Platinum Pets mat. A prior art reference that is otherwise material “is not but-for material if it is merely cumulative.” *Cal. Inst. of Tech. v. Broadcom Ltd.*, 25 F.4th 976, 991 (Fed. Cir. 2022). “A reference is cumulative when it teaches no more than what a reasonable examiner would consider to be taught by the prior art already before the PTO.” *Regen-eron*, 864 F.3d at 1350 (internal quotation marks omitted).

The district court found that each of the prior art references listed by LNC discloses “the surface contact self-sealing characteristic.” J.A. 278-79. It also found Ms. Laurain and Mr. Williams misrepresented the Platinum Pets mat to the PTO as *not* possessing the self-sealing functionality. *See* J.A. 264-68. Because the district court may find, on remand, that these undisclosed prior art references would have taught more than what a reasonable examiner would have considered to have been taught by the misrepresented Platinum Pets mat, we vacate the district court's finding that the Hot Iron holster, the CIBO “Stick Anywhere” placemat, the Momo baby skid-proof silicone placemat, and the Brinware silicone placemat are not material.

LNC next contends that the district court erred in its handling of the deceptive intent requirement. LNC first argues that the district court failed to consider Ms. Laurain's and Mr. Williams' "overall conduct," which in LNC's view "unequivocally established a pattern of deceit." Appellant's Br. at 34.

Acts which are not "per se unreasonable when considered in isolation" may still demonstrate "repeated attempts to avoid playing fair and square with the patent system" and, collectively, support a finding of deceptive intent. *Nilssen v. Osram Sylvania, Inc.*, 504 F.3d 1223, 1235 (Fed. Cir. 2007). When a person having a duty of candor and good faith has engaged in serial misconduct during the prosecution of the same or related patents, it is not enough for a court to consider each individual act of misconduct without also considering the collective whole. *See Ohio Willow Wood Co. v. Alps S., LLC*, 735 F.3d 1333, 1351 (Fed. Cir. 2013) (concluding "collective weight" of evidence of "several misrepresentations . . . made to the PTO" supported finding of deceptive intent); *Paragon Podiatry Lab'y, Inc. v. KLM Lab'ys, Inc.*, 984 F.2d 1182, 1190 (Fed. Cir. 1993) (deceptive intent "must generally be inferred from the facts and circumstances surrounding the applicant's overall conduct"). Because an intent to deceive the PTO can be inferred from a person's "pattern of lack of candor," a district court must consider the person's multiple acts of misconduct "[i]n the aggregate." *Apotex Inc. v. UCB, Inc.*, 763 F.3d 1354, 1362 (Fed. Cir. 2014).

Here, the district court did not apply this legal standard and, thereby, abused its discretion. The district court considered each of Ms. Laurain's and Mr. Williams' individual acts of misconduct in isolation and failed to address the collective weight of the evidence regarding each person's misconduct as a whole. Hence, we vacate the district court's findings on deceptive intent. On remand, the district court must reevaluate Ms. Laurain's deceptive intent

based on her misconduct in the aggregate, and must do the same with respect to Mr. Williams.

We further agree with LNC that the district court wrongly found Ms. Laurain's and Mr. Williams' misrepresentations about the self-sealing functionality of the Platinum Pets mat amounted only to gross negligence, which is insufficient to support a finding of deceptive intent. Instead, the district court's findings that Ms. Laurain and Mr. Williams made a conscious choice to misrepresent the Platinum Pets mat as lacking the self-sealing functionality – despite them having “observed [it] self-sealing to the underlying surface to some extent,” J.A. 267 – should not have been discounted by the district court as merely gross negligence. Such purposeful omission or misrepresentation of key teachings of prior art references may, instead, be indicative of a specific intent to deceive the PTO. *See, e.g., Am. Calcar, Inc. v. Am. Honda Motor Co.*, 768 F.3d 1185, 1190 (Fed. Cir. 2014) (“Partial disclosure of material information about the prior art to the PTO cannot absolve a patentee of intent if the disclosure is intentionally selective.”); *Apotex*, 763 F.3d at 1362 (finding deceptive intent where inventor's misrepresentations about disclosed prior art “were factual in nature and contrary to the true information [the inventor] had in his possession”); *Semiconductor Energy Lab'y Co. v. Samsung Elecs. Co.*, 204 F.3d 1368, 1376 (Fed. Cir. 2000) (finding deceptive intent where patentee made “selective and misleading disclosure” about prior art reference by providing PTO with partial translation of reference that omitted material disclosure). On remand, the district court should analyze whether Ms. Laurain's and Mr. Williams' misrepresentations relating to the Platinum Pets mat, considered in aggregate with their other acts of misconduct, demonstrate that these individuals intended to deceive the PTO.

LNC further alleges that Ms. Laurain and Mr. Williams acted with deceptive intent in submitting declarations to the PTO purportedly containing false statements

regarding “advertising,” “marketing,” “branding,” and “promotional activity,” as well as the impact these actions had on product sales. LNC also faults these declarations for failing to disclose the financial interests of the declarants. The district court analyzed the intent of the declarants themselves but did not expressly address Ms. Laurain’s and Mr. Williams’ intent, other than broadly concluding that the two “did not commit inequitable conduct by submitting these declarations to the USPTO.” J.A. 305. On remand, the district court must make findings as to Ms. Laurain’s and Mr. Williams’ intent with respect to submitting these declarations, as part of the evaluation of the evidence regarding each person’s misconduct as a whole. *See generally Ferring B.V. v. Barr Lab’s, Inc.*, 437 F.3d 1181, 1191 (Fed. Cir. 2006) (“[T]he question of intent is directed to the applicant’s intent, not to the intent of the declarants. Thus, that the declarants may have had no intent to deceive is entirely irrelevant.”).

Accordingly, we vacate the district court’s finding that LNC failed to prove inequitable conduct and we remand for further proceedings, including to allow the district court to revisit its findings on materiality and deceptive intent, consistent with this opinion.

C

We turn next to EZPZ’s appeal from the district court’s grant of summary judgment that the claims of the ’903 patent are invalid due to obviousness. Because genuine disputes of material fact are evident from the record, we vacate the district court’s judgment and remand for further proceedings.

We review a grant of summary judgment in accordance with the law of the regional circuit, here the Fifth Circuit. *See Ineos USA LLC v. Berry Plastics Corp.*, 783 F.3d 865, 868 (Fed. Cir. 2015). The Fifth Circuit reviews grants of summary judgment de novo. *See Keelan v. Majesco Software, Inc.*, 407 F.3d 332, 338 (5th Cir. 2005). Summary

judgment is appropriate where there is no genuine dispute of material fact and the moving party is entitled to judgment as a matter of law. *See Johnson v. World All. Fin. Corp.*, 830 F.3d 192, 195 (5th Cir. 2016). A dispute is genuine where a reasonable fact finder could find for the non-moving party. *See id.* In assessing whether a dispute is genuine the court must “view the evidence and all factual inferences from that evidence in the light most favorable to the party opposing the motion” and must resolve “all reasonable doubts about the facts . . . in favor of the nonmoving litigant.” *Bryan v. McKinsey & Co.*, 375 F.3d 358, 360 (5th Cir. 2004).

Obviousness is a question of law based on underlying facts. *See KSR Int'l Co. v. Teleflex Inc.*, 550 U.S. 398, 427 (2007). The underlying facts to be found include: (1) the scope and content of the prior art; (2) differences between the prior art and the claims at issue; (3) the level of ordinary skill in the pertinent art; and (4) secondary considerations such as commercial success, long felt but unsolved needs, and failure of others. *See Graham v. John Deere Co.*, 383 U.S. 1, 17-18 (1966). A determination of obviousness “requires consideration of all four *Graham* factors, and it is error to reach a conclusion of obviousness until all those factors are considered.” *Apple Inc. v. Samsung Elecs. Co.*, 839 F.3d 1034, 1048 (Fed. Cir. 2016) (en banc). “Objective indicia of nonobviousness must be considered in every case where present.” *Id.*

1

We agree with EZPZ that the district court impermissibly made findings of fact regarding the disclosures of the Webb Prior Art. Taking the evidence in the light most favorable to EZPZ as the nonmoving party, a reasonable factfinder could find – but alternatively, and crucially, could also *not* find – that the Webb Prior Art discloses the self-sealing functionality claimed in the '903 patent. Because the record contains sufficient evidence from which a

reasonable factfinder could find that this disputed claim element is not disclosed by the Webb Prior Art, there is a genuine dispute of material fact. It was, thus, error for the district court to determine that the challenged claims would have been obvious to a person of ordinary skill in the art based on the combination of the Webb Prior Art and Bass.

The Webb Prior Art discloses embodiments in which an elastomeric deformity of the mat pulls the underside of the mat away from the support surface and creates a vacuum to maintain the mat in position. This mechanism of operation, according to EZPZ, is “mutually exclusive” from the self-sealing functionality claimed in the '903 patent. Appellee's Br. at 54. EZPZ's contention is supported by the testimony of two experts, Michael Henley and John Kennedy, both of whom opine that the Webb Prior Art does not teach self-sealing. *See, e.g.*, J.A. 1731 (Henley: “[T]he Webb patent and Tommee Tippee product also fail to disclose the surface contact self-sealing attribute [of] the '903 Patent and invention. . . . [I]t is my opinion that the Webb patent and the commercialized Tommee Tippee product examples both fail to anticipate or render obvious the '903 Patent Claims.”); J.A. 1837 (Kennedy: “Webb does not teach at least the recited operations of ‘causing surface contact self-sealing upon an underlying surface by placing [the mat upon the underlying surface]’ and ‘causing creation of a partial vacuum’”) (brackets in original). In evaluating whether LNC is entitled to summary judgment, EZPZ's evidence on this material point must be credited. *See Anderson v. Liberty Lobby, Inc.*, 477 U.S. 242, 255 (1986) (“The evidence of the non-movant is to be believed, and all justifiable inferences are to be drawn in his favor.”). Doing so, it is evident that one of ordinary skill could find that the Webb Prior Art does not disclose the self-sealing limitation of the claims of the '903 patent and, hence, could conclude that those claims have not been proven obvious.

The district court similarly erred by finding as a fact that the Webb Prior Art's disclosure of "sticky" materials means that a person of ordinary skill in the art would necessarily read those prior art references as teaching self-sealing. On this point, too, the record contains sufficient evidence, taken in the light most favorable to EZPZ as the non-moving party, to support a finding that the Webb Prior Art nonetheless does not teach self-sealing. *See, e.g.*, J.A. 1837 (EZPZ's expert, Kennedy, opining that Webb Prior Art "sticks to the surface only because the plate was originally pushed downward onto the suction cup . . . , and the suction area . . . was engaged with the table, . . . [which] is a fundamentally different method of operation" from that of '903 patent). Whether prior art discloses a claim limitation is a question of fact, *see Fleming v. Cirrus Design Corp.*, 28 F.4th 1214, 1221-22 (Fed. Cir. 2022), and the district court should not have resolved this dispute in favor of the moving party, LNC, on summary judgment.

A reasonable factfinder might also choose to place weight on the fact that during the *ex parte* reexamination of the '903 patent, the PTO considered the Webb Prior Art and found it does not teach self-sealing. *See* J.A. 15975 (examiner explaining reasons for patentability as including that Webb Prior Art mat "does not self-seal"). The decision whether to admit evidence of reexamination at trial is left to the discretion of a district court. *See generally Callaway Golf Co. v. Acushnet Co.*, 576 F.3d 1331, 1343 (Fed. Cir. 2009) (finding district court did not abuse its discretion in excluding evidence regarding non-final reexamination determinations from jury). Nevertheless, where, as here, reexamination evidence is offered by a patentee in connection with opposing summary judgment of invalidity (or reconsideration thereof), and is neither excluded nor deemed inadmissible by the district court, it is error to find a lack of a genuine dispute of material fact by ignoring,

dismissing, or discounting the probative value of the reexamination evidence in the record.²

LNC's arguments for affirmance are unpersuasive. Relying on *Union Carbide Corp. v. Am. Can Co.*, 724 F.2d 1567, 1573 (Fed. Cir. 1984), LNC argues that where prior art references are "readily understandable," the district court may construe them without expert testimony and may then determine there is no genuine issue of material fact as to what they show. Even accepting that this is sometimes possible, here the testimony of EZPZ's experts is, as we have explained, in direct conflict with the district court's understanding of the Webb Prior Art. This creates a genuine dispute of material fact.

LNC's focus on a single sentence in the specification of the Webb Prior Art, purportedly mandating that Webb be understood as disclosing a self-sealing embodiment, also

² LNC's reliance on *Exmark Manufacturing Co. v. Briggs & Stratton Power Products Group, LLC*, 879 F.3d 1332 (Fed. Cir. 2018), does nothing to alter our conclusion. In *Exmark*, we vacated a grant of summary judgment of *no invalidity* that had been based solely on a reexamination certificate confirming patentability. *See id.* at 1340-44. This is consistent with our holding today that, in evaluating LNC's motion for summary judgment of *invalidity*, EZPZ's reexamination certificate might have been considered as evidence of validity – although it is not dispositive of whether LNC can prove invalidity by clear and convincing evidence. *See generally Fromson v. Advance Offset Plate, Inc.*, 755 F.2d 1549, 1555 (Fed. Cir. 1985) (stating that district courts are not bound by PTO reexamination decisions although they "must consider" such decisions as evidence "in determining whether the party asserting invalidity has met its statutory burden by clear and convincing evidence").

lacks merit.³ LNC's contention requires us to draw an inference against EZPZ from the disclosure of the Webb Prior Art, which is improper on summary judgment, especially in light of contrary evidence in the record. *See, e.g.*, J.A. 1837.

Finally, LNC points to what it contends is a contradiction between the bench trial testimony and the report of EZPZ's expert, Mr. Henley, on the matter of whether the Webb Prior Art discloses self-sealing. *Compare* J.A. 51, 14575-78 (district court finding Mr. Henley testified that Webb "discloses every element recited in independent claim 1 [of the '903 patent] except an integrated tableware with a receptacle") *with* J.A. 1730-31 (Mr. Henley opining Webb also "fail[s] to disclose the surface contact self-sealing attribute [of] the '903 Patent and invention"). The seeming inconsistency in the views expressed by EZPZ's expert does no more for LNC than show a genuine dispute of material fact, making summary judgment unwarranted. Moreover, EZPZ's second expert, Mr. Kennedy, opined that the Webb Prior Art does not disclose self-sealing, *see* J.A.

³ The sentence reads as follows:

By creating the small volume 38 which is a vacuum or at least a partial vacuum, this serves *further* to hold the mat 10 against the surface 12, thereby increasing the efficiency of the holding action of the mat 10 upon the surface 12 and in particular, enhancing the suction effect of the concavity 31.

J.A. 1099 (emphasis added). The district court concluded that "further" requires the disclosed embodiment to self-seal, as the word "would not be necessary if the mat had not already adhered or self-sealed to the underlying surface before the small volume 38 was created." J.A. 59-60.

1837, and LNC identifies no purportedly contradictory position espoused by him.

In sum, there is a genuine dispute of material fact as to whether the Webb Prior Art discloses the seal-sealing functionality claimed in the '903 patent. Such disputes must be submitted to the trier of fact, not resolved as a matter of law by the trial court on a motion for summary judgment.

2

We agree with EZPZ that the district court also improperly resolved genuine disputes of material fact concerning the Tommee Tippee mat. There is evidence from which a reasonable factfinder could find that the Tommee Tippee mat is not an embodiment of the Webb Prior Art. *See, e.g.*, J.A. 18709 (LNC's expert opining: "In contrast to some of the figures in both the Webb Pub. and Webb patent, there is no small concavity or dimple whatsoever on the undersurface of the Tommee Tippee planar portion."); J.A. 14579 (EZPZ's expert stating there is "a difference between what was disclosed in the Webb patent and the Tommee Tippee embodiment"). The record also contains evidence of multiple versions of the Tommee Tippee mat, and the parties genuinely dispute whether each version operates in the same manner. *See* J.A. 42-44 (district court referencing both *blue* Tommee Tippee mat, which was "included in the market research summary document compiled by Mrs. Laurain," and *pink* Tommee Tippee mat, which was introduced by LNC during bench trial). EZPZ's expert, Mr. Henley, testified that the two mats were different, with the "pink Tommee Tippee mat" being "better" than the "aqua or blue Tommee Tippee mat." J.A. 14569-70. Further proceedings will be required to enable a factfinder to make the material factual determinations as to the relationship between the Tommee Tippee mat and the Webb Prior Art.

3

On remand, more analysis may also be necessary on the issue of motivation to combine. Whether a skilled artisan would have been motivated to modify or combine disclosures in the prior art is a question of fact. *See Univ. of Strathclyde v. Clear-Vu Lighting LLC*, 17 F.4th 155, 160 (Fed. Cir. 2021). On this genuinely disputed point, the district court found only that “it would have been common sense to the hypothetical person of ordinary skill in the art to make the integrated tableware and dining mat disclosed in Bass out of the rubberlike, nontoxic material disclosed in the Webb Publication and the Tommee Tippee Mat.” J.A. 58-59. “[O]n summary judgment, to invoke ‘common sense’ or any other basis for extrapolating from prior art to a conclusion of obviousness, a district court must articulate its reasoning with sufficient clarity for review.” *Perfect Web Techs., Inc. v. InfoUSA, Inc.*, 587 F.3d 1324, 1330 (Fed. Cir. 2009); *see also Plantronics, Inc. v. Aliph, Inc.*, 724 F.3d 1343, 1354 (Fed. Cir. 2013) (stating that obviousness findings “grounded in ‘common sense’ must contain explicit and clear reasoning providing some rational underpinning why common sense compels a finding of obviousness”). The district court has not yet met this obligation, which – depending on how it resolves other issues – it may need to confront on remand.

4

Factual issues concerning the objective indicia of non-obviousness further preclude the grant of summary judgment.⁴ *See Medtronic, Inc. v. Teleflex Innovations S.a.r.l.*,

⁴ We do not agree with EZPZ that the district court is required address the objective indicia of non-obviousness *before* analyzing *prima facie* obviousness. *See Adapt Pharma Operations Ltd. v. Teva Pharms. USA, Inc.*, 25 F.4th 1354, 1372 (Fed. Cir. 2022) (“Although the district court’s analysis of the objective indicia in the opinion

70 F.4th 1331, 1339 (Fed. Cir. 2023) (“It is well established that copying by a competitor . . . may be evidence that the patented invention is nonobvious.”); *Merck & Co. v. Teva Pharms. USA, Inc.*, 395 F.3d 1364, 1376 (Fed. Cir. 2005) (“Commercial success is relevant [to nonobviousness] because the law presumes an idea would successfully have been brought to market sooner, in response to market forces, had the idea been obvious to persons skilled in the art.”). The district court was required to consider objective indicia evidence in the record and to do so in the light most favorable to EZPZ, drawing all reasonable inferences in favor of EZPZ, as the non-moving party. Instead, the district court improperly resolved genuine disputes of material fact, including whether a nexus exists between the commercial success of EZPZ’s product and its patented features. *See, e.g., Pro-Mold & Tool Co. v. Great Lakes Plastics, Inc.*, 75 F.3d 1568, 1573-74 (Fed. Cir. 1996) (vacating summary judgment of obviousness because genuine issue of material fact existed as to commercial success nexus).

The record here is one that requires review by a factfinder, to determine which (if any) objective indicia are established, and then to weigh those findings against the affirmative evidence of obviousness introduced by LNC. For instance, the record contains evidence from which a reasonable factfinder might find that: (i) LNC copied EZPZ’s technology, *see, e.g., J.A. 15966; see also J.A. 15975* (PTO finding “[i]t is clear that the invention has been copied by many other entities”); and (ii) EZPZ’s product, embodying its patent claims, enjoyed commercial success, *see,*

follows its discussion of the prima facie case of obviousness, there is nothing inherently wrong with that.”). Our disagreement with EZPZ on this point does not, however, affect our conclusion that summary judgment of obviousness should not have been granted.

e.g., J.A. 2365-66, J.A. 15975 (PTO finding “the invention itself has le[d] to it[s] commercial success”). *See also generally* J.A. 15975 (PTO concluding during *ex parte* reexamination of ’903 patent that “secondary considerations, when looked at as a whole, provide sufficient evidence to support non-obviousness”). In short, the evidence presented by EZPZ creates a genuine dispute of material fact as to whether the objective indicia of non-obviousness overcome LNC’s prima facie case (assuming it has made out one) of obviousness.

We recognize that in certain circumstances, for example, where inventions represent “no more than the predictable use of prior art elements according to their established functions, the secondary considerations” will prove to be “inadequate to establish nonobviousness as a matter of law.” *Wyers v. Master Lock Co.*, 616 F.3d 1231, 1246 (Fed. Cir. 2010) (internal quotations marks omitted). Here, however, given the numerous genuine issues of material fact – including whether the prior art references disclose essential claim elements – it cannot be said on the present record that LNC has made out such a strong prima facie case that obviousness can be determined as a matter of law, notwithstanding the evidence of objective indicia of nonobviousness. *See, e.g., Plantronics*, 724 F.3d at 1357 (reversing summary judgment of obviousness because evidence pertaining to objective considerations raised genuine issues of material fact); *Mintz v. Dietz & Watson, Inc.*, 679 F.3d 1372, 1379-80 (Fed. Cir. 2012) (vacating summary judgment of obviousness where, among other things, district court failed to properly consider evidence of secondary considerations); *Transocean Offshore Deepwater Drilling, Inc. v. Maersk Contractors USA, Inc.*, 617 F.3d 1296, 1305 (Fed. Cir. 2010) (reversing summary judgment of obviousness because district court failed to consider objective evidence of nonobviousness); *Cont’l Can Co. USA, Inc. v. Monsanto Co.*, 948 F.2d 1264, 1274 (Fed. Cir. 1991) (vacating summary

judgment of obviousness because disputed fact issues existed regarding secondary considerations).

Accordingly, we vacate the district court's grant of summary judgment that the claims of the '903 patent are invalid as obvious and remand this issue for further proceedings.⁵

D

Finally, we address LNC's appeal from the district court's denial of its motion for attorney fees under 35 U.S.C. § 285 and the related denial of its request for costs.

Pursuant to § 285, a court “in exceptional cases may award reasonable attorney fees to the prevailing party.” This inquiry “requires a two-step analysis. The district court must determine whether the case is ‘exceptional;’ if it is, then it is within the court’s discretion to award attorneys’ fees to the prevailing party.” *J.P. Stevens Co. v. Lex Tex Ltd., Inc.*, 822 F.2d 1047, 1050 (Fed. Cir. 1987). An “exceptional” case is “simply one that stands out from others with respect to the substantive strength of a party’s litigating position (considering both the governing law and the facts of the case) or the unreasonable manner in which the case was litigated.” *Octane Fitness, LLC v. ICON Health & Fitness, Inc.*, 572 U.S. 545, 554 (2014). The determination of whether a case is “exceptional” requires the

⁵ During argument, EZPZ suggested that a jury trial on invalidity would not be necessary if the district court, on remand, determines that inequitable conduct renders the '903 patent unenforceable. *See* Oral Argument 24:50-25:17 (EZPZ conceding that finding of inequitable conduct would be dispositive of entire case). We leave it to the district court to decide which issues it wishes to proceed on first and what impact the resolution of any remanded issue should have on the remainder of the case.

consideration of “the totality of the circumstances” on a case-by-case basis. *Id.*

“We review a district court’s determination of whether a litigant is a prevailing party under § 285 de novo, applying Federal Circuit law.” *Dragon Intell. Prop., LLC v. Dish Network LLC*, 956 F.3d 1358, 1361 (Fed. Cir. 2020). “We review a district court’s exceptional-case determination and award of fees under § 285 for abuse of discretion.” *In re PersonalWeb Techs. LLC*, 85 F.4th 1148, 1153 (Fed. Cir. 2023). “An abuse of discretion occurs when a district court’s decision commits legal error or is based on a clearly erroneous assessment of the evidence.” *Raniere v. Microsoft Corp.*, 887 F.3d 1298, 1303 (Fed. Cir. 2018).

LNC argues that the district court committed legal error by failing to declare LNC is the prevailing party. We agree.

For purposes of awarding attorney fees under § 285, “there can be only one winner.” *Shum v. Intel Corp.*, 629 F.3d 1360, 1367 (Fed. Cir. 2010). “[I]n identifying a prevailing party, we must consider whether the district court’s decision effects or rebuffs a plaintiff’s attempt to effect a material alteration in the legal relationship between the parties.” *B.E. Tech., L.L.C. v. Facebook, Inc.*, 940 F.3d 675, 679 (Fed. Cir. 2019) (internal quotation marks omitted).

We agree with LNC that it is the prevailing party. LNC brought this case against EZPZ, requesting, among other things, a declaratory judgment of non-infringement, invalidity, and unenforceability of LNC’s ’903 patent. By proving unclean hands – a decision we are affirming today – LNC obtained the dismissal with prejudice of EZPZ’s then-remaining counterclaims, including its claim for infringement of the ’903 patent. *See Highway Equip. Co. v. FEEO, Ltd.*, 469 F.3d 1027, 1035 (Fed. Cir. 2006) (“[T]he dismissal with prejudice . . . has the necessary judicial imprimatur to constitute a judicially sanctioned change in the legal relationship of the parties . . .”). Consequently, LNC

successfully achieved a material alteration in its legal relationship to EZPZ, which no longer has the ability to enforce the '903 patent against LNC's accused products. See *United Cannabis Corp. v. Pure Hemp Collective Inc.*, 66 F.4th 1362, 1368 (Fed. Cir. 2023) (finding party prevailed where opposing party “can never again assert the same patents against . . . [the] same accused products”).

It is true that LNC did not prevail on its LUTPA claims and the district court dismissed its Lanham Act claims without prejudice. It is further true that we are remanding inequitable conduct and obviousness, so it may turn out that LNC ultimately fails to prove the '903 patent is unenforceable and obvious. But a party is not required “to prevail on all claims in order to qualify as a prevailing party.” *Shum*, 629 F.3d at 1367-68. Furthermore, nothing remaining in this case could alter the reality that LNC has already obtained the material alteration of its relationship with EZPZ because, henceforth, EZPZ is barred by its unclean hands from obtaining relief from LNC based on its remaining counterclaims, including for infringement of the '903 patent, the '327 design patent, and trade dress.

LNC next contends that the district court abused its discretion by not deeming this case exceptional. Evaluating whether a case is exceptional requires consideration of the “totality of the circumstances,” including “the substantive strength of a party’s litigating position” and the “manner in which the case was litigated.” *Octane Fitness*, 572 U.S. at 554. While the district court is not required to articulate its assessment of every consideration, “it must actually assess the totality of the circumstances.” *AdjustaCam, LLC v. Newegg, Inc.*, 861 F.3d 1353, 1360 (Fed. Cir. 2017).

Because this case is far from over – as explained above, we are remanding for further proceedings to determine if the claims of the '903 patent are invalid for obviousness and unenforceable due to Ms. Laurain and Mr. Williams

committing inequitable conduct – and it is, accordingly, not yet possible to assess the “totality” of circumstances, we remand for the district court to evaluate whether this case is exceptional at its conclusion; and, further, for the district court to decide whether to exercise its discretion to award attorney fees if it ultimately deems this case exceptional.⁶

We reach the same conclusion with respect to LNC’s appeal of the district court’s decision to deny its request to recover its costs pursuant to Federal Rule of Civil Procedure 54(d). The Fifth Circuit, whose law governs this issue in this case, applies “a strong presumption that the prevailing party will be awarded costs.” *Pacheco v. Mineta*, 448 F.3d 783, 793 (5th Cir. 2006). A district court that denies or reduces a cost award to a prevailing party must articulate justifications for so doing. *See id.* at 794.

Here, the district court denied LNC’s request for costs due to (at least in part) the “close and difficult legal issues presented in this case.” J.A. 333. While, as we have said, LNC is the prevailing party – and will remain so no matter how the remand turns out – the district court should have an opportunity to reevaluate the closeness of the case, and any other factors it deems pertinent to whether the “strong presumption” in favor of awarding costs has been overcome, after it resolves the issues we are remanding to it.

Accordingly, we vacate the district court’s order denying LNC’s motion for attorney fees and refusing to award

⁶ In saying this we do not mean to suggest that district courts lack discretion to decide for themselves whether to resolve § 285 motions before or after liability issues are appealed. Moreover, because we are vacating the finding of no exceptionality, we need not address LNC’s contention that the district court failed to apply the correct legal standard in assessing whether this is an exceptional case.

LUV N' CARE, LTD. v. LAURAIN

35

costs, and remand these matters for further consideration consistent with this opinion.

III

We have considered LNC's and EZPZ's remaining arguments and find them unpersuasive. For the foregoing reasons, we affirm the district court's judgment on the doctrine of unclean hands; vacate its judgment on inequitable conduct, invalidity, attorney fees and costs; and remand for further proceedings consistent with this opinion.

AFFIRMED-IN-PART, VACATED-IN-PART, AND REMANDED

COSTS

No costs.