

2023-2346

In the United States Court of Appeals
for the Federal Circuit



LYNK LABS, INC.,

Appellant,

-v-

SAMSUNG ELECTRONICS CO., LTD.,

Appellee.

On Appeal from the USPTO Patent Trial and Appeal Board
No. IPR2022-00149 for U.S. Patent No. 10,687,400

Opening Brief of Appellant Lynk Labs, Inc.

James T. Carmichael*
Stephen T. Schreiner
Stephen P. McBride
Mitch Yang*
CARMICHAEL IP, PLLC
8607 Westwood Center Drive, Suite 270
Tysons Corner, VA 22182
(703) 646-9255
jim@carmichaelip.com
schreiner@carmichaelip.com
stevemcbride@carmichaelip.com
mitch@carmichaelip.com
**Not admitted in Virginia*

Counsel for Appellant Lynk Labs, Inc.

January 10, 2024

PATENT CLAIMS AT ISSUE*

U.S. Patent No. 10,687,400, Claim 7:

7. A lighting system comprising: [a]

an LED circuit array comprising an LED circuit comprising a plurality of LEDs connected in series; [b]

a capacitor; [d]

a bridge rectifier configured to receive an input AC voltage from a mains power source; [d]

a driver connected to the bridge rectifier and configured to provide a rectified output AC voltage to the LED circuit array; [e]

wherein a forward voltage of the LEDs of the LED circuit array matches the rectified input AC voltage output of the driver; [f] and

wherein the LED circuit array, the capacitor, the bridge rectifier, and the driver are all mounted on a single substrate. [g]

* The letter annotations ([a], [b], etc.) identifying claim limitations correspond to those identified by the parties in the IPR papers.

CERTIFICATE OF INTEREST

I certify the following information is accurate and complete to the best of my knowledge.

Respectfully submitted,

/s/ Stephen T. Schreiner
Stephen T. Schreiner
Counsel for Appellant Lynk Labs, Inc.

1. Represented Entity

Lynk Labs, Inc.

2. Real Party in Interest

N/A

3. Parent Corporation and Stockholders

N/A

4. Legal Representatives

Other than counsel who have entered an appearance in this court, the following counsel have made previous appearances in lower court proceedings:

Erik J. Halverson, Katherine L. Allor, and Dennis J. Majewski of the firm K&L Gates, LLP

5. Related Cases

A Notice of Related Case Information was filed on August 6, 2023, ECF No. 4.

6. Organizational Victims and Bankruptcy cases

N/A

TABLE OF CONTENTS

	<u>Page</u>
PATENT CLAIMS AT ISSUE.....	i
CERTIFICATE OF INTEREST.....	ii
TABLE OF AUTHORITIES.....	vii
STATEMENT OF RELATED CASES.....	1
JURISDICTIONAL STATEMENT.....	2
STATEMENT OF THE ISSUES.....	3
STATEMENT OF THE CASE.....	4
I. THE '400 PATENT.....	4
A. The Invention Disclosed in the '400 Patent.....	4
B. The Claims of the '400 Patent.....	5
II. THE REFERENCES.....	6
A. Nerone (U.S. Pat. No. 6,411,045) (Ex. 1032).....	6
B. Martin (U.S. Pat. Pub. 2004/0206070) (Ex. 1015).....	7
III. PROCEDURAL HISTORY.....	8
SUMMARY OF THE ARGUMENT.....	11
ARGUMENT.....	13
I. STANDARDS OF REVIEW.....	13
II. THE BOARD’S CONSTRUCTION OF LIMITATION 7(b) FOR “AN LED CIRCUIT COMPRISING A PLURALITY OF LEDs CONNECTED IN SERIES” IS LEGALLY ERRONEOUS.....	14
A. Introduction.....	14

TABLE OF CONTENTS (Cont.)

B. The Claim Language Demonstrates that the Board’s Construction of “an LED Circuit Comprising a Plurality of LEDs Connected in Series” is Erroneous19

1. The plain language of limitation 7(b) contradicts the Board’s construction.....20

2. The language used in other claims in the ’400 Patent demonstrates the Board’s construction is erroneous.....22

C. The Specification of the ’400 Patent Confirms that the Board’s Construction is Erroneous24

III. INDEPENDENT CLAIM 7 AND DEPENDENT CLAIMS 8-13 ARE PATENTABLE WHEN THE PROPER CLAIM CONSTRUCTION IS APPLIED FOR LIMITATION 7(b)’s “AN LED CIRCUIT COMPRISING A PLURALITY OF LEDs CONNECTED IN SERIES”34

A. The Board’s Determination Was Based on Nerone’s Disclosure that Each Group 410 of LEDs Is In Series With the Other Groups 410.....34

B. The Board Made No Finding That Any Single LED in Nerone Is Connected In Series With Another LED, And There Is No Evidence of Record To Support Such a Finding35

IV. THE BOARD’S CONSTRUCTION OF “FORWARD VOLTAGE OF THE LEDs OF THE LED CIRCUIT ARRAY MATCHES THE RECTIFIED [] AC VOLTAGE OUTPUT OF THE DRIVER” IN LIMITATION 7(f) IS LEGALLY ERRONEOUS38

A. Introduction38

B. The Claim Language Demonstrates that the Board’s Construction Is Erroneous.....40

TABLE OF CONTENTS (Cont.)

C. The Specification of the '400 Patent Confirms that the Board's Construction is Erroneous40

V. INDEPENDENT CLAIM 7 AND DEPENDENT CLAIMS 8-13 ARE PATENTABLE WHEN THE PROPER CLAIM CONSTRUCTION IS APPLIED FOR LIMITATION 7(f)'s "FORWARD VOLTAGE OF THE LEDs OF THE LED CIRCUIT MATCHES THE RECTIFIED [] AC VOLTAGE OUTPUT OF THE DRIVER"45

A. The Board's Determination Must Be Reversed Because It is Based on the Application of the Board's Erroneous Construction of "Matches"45

B. The Undisputed Record Evidence Demonstrates Claim 7 Is Patentable When The Correct Claim Construction Is Applied Because Martin Teaches That The Voltage Output Is Less Than The Forward Voltage Of The LEDs.....46

C. Besides Its Erroneous Construction of "Matches," The Board Applied An Incorrect Construction of Limitation 7(f) That Reads Out The Requirement That A "Rectified AC Voltage Output" Matches the Forward Voltage of the LEDs48

D. The Board's Determination That the Petitioner Can Meet the "Matches" Limitation Without Determining Any Numerical Value is an Error of Law53

VI. THE BOARD'S DECISION MUST BE REVERSED AS TO CLAIMS 7-13 AND 17 BECAUSE THE MARTIN REFERENCE OF GROUNDS 1-6 IS NOT "PRINTED PUBLICATION" PRIOR ART WITHIN THE MEANING OF 35 U.S.C. § 311(b).....57

A. Martin Is Not a Prior Art "Printed Publication" Because It Was Not Publicly Accessible Until After the '400 Patent's Priority Date58

B. The Board Misconstrued the Statute.....59

TABLE OF CONTENTS (Cont.)

CONCLUSION 67
CERTIFICATE OF FILING AND SERVICE 68
CERTIFICATE OF COMPLIANCE 69
ADDENDUM 70

TABLE OF AUTHORITIES

Page

CASES

AC Technologies S.A. v. Amazon.com, Inc.,
 912 F.3d 1358 (Fed. Cir. 2019)13

Acceleration Bay, LLC v. Activision Blizzard Inc.,
 908 F.3d 765 (Fed. Cir. 2018) 58, 59, 63

Azar v. Allina Health Servs.,
 139 S. Ct. 1804 (2019).....63

B/E Aerospace, Inc. v. C & D Zodiac, Inc.,
 709 F. App’x 687 (Fed. Cir. 2017)58

Becton, Dickinson & Co. v. Baxter Corp. Englewood,
 998 F.3d 1337 (Fed. Cir. 2021)65

Belden Inc. v. Berk-Tek LLC,
 805 F.3d 1064 (Fed. Cir. 2015)13

Belkin Intern., Inc. v. Kappos,
 696 F.3d 1379 (Fed. Cir. 2012)14

Brown v. Guild,
 90 U.S. 181 (1874).....60

Carrum Technologies, LLC v. Unified Patents, LLC,
 2021 WL 3574209 (Fed. Cir. Aug. 13, 2021)49

Cordis Corp. v. Boston Sci. Corp.,
 561 F.3d 1319 (Fed. Cir. 2009)59

Genentech, Inc. v. Immunex Rhode Island Corp.,
 964 F.3d 1109 (Fed. Cir. 2020)14

GPNE Corp. v. Apple Inc.,
 830 F.3d 1365 (Fed. Cir. 2016) 33, 44

In re Cronyn,
 890 F.2d 1158 (Fed. Cir. 1989) 58, 63

TABLE OF AUTHORITIES (Cont.)

	<u>Page</u>
<i>In re Hall</i> , 781 F.2d 897 (Fed. Cir. 1986)	63
<i>In re Klopfenstein</i> , 380 F.3d 1345 (Fed. Cir. 2004)	58, 63
<i>In re Lister</i> , 583 F.3d 1307 (Fed. Cir. 2009)	58
<i>In re Stepan Co.</i> , 868 F.3d 1342 (Fed. Cir. 2017)	13, 56
<i>In re Wertheim</i> , 646 F.2d 527 (CCPA 1981)	60
<i>In re Wyer</i> , 655 F.2d 221 (CCPA 1981)	63
<i>Interurban Ry. & Terminal Co. v. Westinghouse Elec. & Mfg. Co.</i> , 186 F. ___ 166 (6th Cir. 1911)	61
<i>Irdeto Access, Inc. v. Echostar Satellite Corp.</i> , 383 F.3d 1295 (Fed. Cir. 2004)	33, 44
<i>Jazz Pharms., Inc. v. Amneal Pharms., LLC</i> , 895 F.3d 1347 (Fed. Cir. 2018)	63
<i>Kinetic Concepts, Inc. v. Smith & Nephew, Inc.</i> , 688 F.3d 1342 (Fed. Cir. 2012)	56
<i>Knowles Elecs. LLC v. Iancu</i> , 886 F.3d 1369 (Fed. Cir. 2018)	20
<i>Lyman Ventilating & Refrigerator Co. v. Lalor</i> , 15 F. Cas. 1163 (C.C.S.D.N.Y. 1874)	61
<i>Maxwell v. J. Baker, Inc.</i> , 86 F.3d 1098 (Fed. Cir. 1996)	22
<i>Merck Sharp & Dohme Corp. v. Microspherix LLC</i> , 814 F. App'x. 575 (Fed. Cir. 2020)	65

TABLE OF AUTHORITIES (Cont.)

	<u>Page</u>
<i>Motionless Keyboard Co. v. Microsoft Corp.</i> , 486 F.3d 1376 (Fed. Cir. 2007)	13
<i>Outdry Technologies Corporation v. Geox S.P.A.</i> , 859 F.3d 1364 (Fed. Cir. 2017)	13
<i>Pacing Technologies, LLC v. Garmin Intern., Inc.</i> , 778 F.3d 1021 (Fed. Cir. 2015)	41
<i>Personalized Media Communications, LLC v. Apple Inc.</i> , 952 F.3d 1336 (Fed. Cir. 2020)	34
<i>Phillips v. AWH Corp.</i> , 415 F.3d 1303 (Fed. Cir. 2005)	20, 22, 24, 33, 44, 49
<i>Polaris Indus., Inc. v. Arctic Cat, Inc.</i> , 882 F.3d 1056 (Fed. Cir. 2018)	19
<i>PPC Broadband, Inc. v. Corning Optical Communications RF, LLC</i> , 815 F.3d 734 (Fed. Cir. 2016)	13
<i>Purdue Pharma L.P. v. Iancu</i> , 767 F. App'x 918 (Fed. Cir. 2019)	64, 65
<i>Qualcomm Inc. v. Apple Inc.</i> , 24 F.4th 1367 (Fed. Cir. 2022)	53, 57, 60, 65, 66
<i>Qualcomm Inc. v. Intel Corp.</i> , 6 F.4th 1256 (Fed. Cir. 2021)	13, 22, 33, 43
<i>Res-Care, Inc. v. United States</i> , 735 F.3d 1384 (Fed. Cir. 2013)	60
<i>Samsung Electronics Co. v. Infobridge Pte. Ltd.</i> , 929 F.3d 1363 (Fed. Cir. 2019)	62, 63
<i>SAS Inst., Inc. v. Iancu</i> , 138 S. Ct. 1348 (2018)	62
<i>Thorner v. Sony Computer Entm't Am LLC</i> , 669 F.3d 1362 (Fed. Cir. 2012)	41

TABLE OF AUTHORITIES (Cont.)

	<u>Page</u>
<i>TQ Delta, LLC v. CISCO Systems, Inc.</i> , 942 F.3d 1352 (Fed. Cir. 2019)	56
<i>Ultratec, Inc. v. CaptionCall, LLC</i> , 872 F.3d 1267 (Fed. Cir. 2017)	22
<i>Unique Concepts, Inc. v. Brown</i> , 939 F.2d 1558 (Fed. Cir. 1991)	22
<i>Univ. of Strathclyde v. Clear-Vu Lighting LLC</i> , 17 F.4th 155 (Fed. Cir. 2021)	13
<i>Valve Corp. v. Ironburg Inventions Ltd.</i> , 8 F.4th 1364 (Fed. Cir. 2021)	63
<i>Ventana Medical Sys., Inc. v. Biogenex Laboratories, Inc.</i> , 473 F.3d 1173 (Fed. Cir. 2006)	49
<i>VirnetX, Inc. v. Cisco Sys., Inc.</i> , 767 F.3d 1308 (Fed. Cir. 2014)	33, 44
<i>Vitronics Corp. v. Conceptronic, Inc.</i> , 90 F.3d 1576 (Fed. Cir. 1996)	20
<i>Voter Verified, Inc. v. Premier Election Sols., Inc.</i> , 698 F.3d 1374 (Fed. Cir. 2012)	63
<i>Williamson v. Citrix Online, LLC</i> , 792 F.3d 1339 (Fed. Cir. 2015)	13, 22

STATUTES

28 U.S.C. § 1295	2
35 U.S.C. § 102	60, 65
35 U.S.C. § 122	59
35 U.S.C. § 141	2
35 U.S.C. § 311	3, 12

TABLE OF AUTHORITIES (Cont.)

	<u>Page</u>
35 U.S.C. § 319.....	2
PATENT PROCEDURES	
Post-AIA § 102.....	61, 63
Pre-AIA § 102	3, 59, 60, 61, 62, 63

STATEMENT OF RELATED CASES

This is an appeal from the final written decision (“FWD”) in *Samsung Electronics Co., Ltd. v. Lynk Labs, Inc.*, IPR2022-00149, Paper 33 (PTAB June 26, 2023) by the United States Patent and Trademark Office Patent Trial and Appeal Board (“PTAB” or “Board”) for U.S. Pat. No. 10,687,400 (“the ’400 Patent”). Appx0001-0070 [FWD]. No appeal in or from the same proceeding in this PTAB was previously before this Court or any other appellate court.

There is one pending district litigation involving the ’400 Patent. Samsung Electronics Co., Ltd. (“Samsung” or “Petitioner”) filed a declaratory judgment action on May 17, 2021, against Lynk Labs Inc. (“Lynk” or “Patent Owner”) involving the ’400 Patent in *Samsung Electronics Co., Ltd. and Samsung Electronics America, Inc. v. Lynk Labs, Inc.*, Case No. 1:21-cv-02665 (N.D. Ill.). That suit was stayed on March 21, 2023.

JURISDICTIONAL STATEMENT

The PTAB had jurisdiction under 35 U.S.C. § 6 over IPR2022-00149 that is the subject of this appeal. The PTAB issued its Final Written Decision in IPR2022-00149 on June 26, 2023. Appx0001-0070 [FWD]. Lynk timely filed its notice of appeal on August 25, 2023. Appx6566-6571 [NoA, 1-6]. This Court has jurisdiction under 35 U.S.C. §§ 141(c) , 319 and 28 U.S.C. § 1295(a)(4)(A).

STATEMENT OF THE ISSUES

1. Whether the Board erred in finding that for the limitation “an LED circuit array comprising an LED circuit comprising a plurality of LEDs connected in series” is properly construed to encompass a plurality of LED circuits/groups of LEDs being connected in series even when there are no LEDs are connected in series.

2. Whether the Board erred by determining that “an LED circuit comprising a plurality of LEDs connected in series” was met in view of the cited references.

3. Whether the Board erred in construing the limitation “wherein a forward voltage of the LEDs ... matches the rectified [] AC voltage output of the driver” encompasses the rectified AC output voltage being “less than” the forward voltage of the LEDs.

4. Whether the Board erred by determining that the limitation for the “forward voltage of the LEDs ... matches the rectified [] AC voltage output of the driver” in Claim 7 was met in view of the cited references.

5. Whether the Board erred in determining that the Martin reference, a published and later abandoned U.S. patent application that could only be prior art under pre-AIA 35 § 102(e)(1), can be applied in an IPR as a “printed publication” under 35 U.S.C. § 311(b).

STATEMENT OF THE CASE

This case is an appeal from the Board’s decision that concluded Claims 7-13 and 15-17 of the ’400 Patent are unpatentable over certain references stated in Petitioner’s grounds. The decision is *Samsung Electronics, Co., Ltd. v. Lynk Labs Inc.*, IPR2022-00149, Paper 33 (PTAB June 26, 2023). Appx0001-0070 [FWD].

I. THE ’400 PATENT

A. The Invention Disclosed in the ’400 Patent

Patent Owner Lynk Labs, Inc. (“Lynk”) is a practicing entity that manufactures and sells its patented products to LED lighting manufacturers for various applications.

The ’400 Patent discloses a variety of LED lighting systems with LED circuits, LED drivers, and other circuit components. The ’400 Patent discloses multiple embodiments of LED circuits with full wave bridge rectifiers and drivers that deliver power to LED circuits.

Figure 24 illustrates a lighting system including an AC power source, a driver 186, a bridge rectifier 30, capacitors, and multiple LED circuits 324 with LEDs connected in series. Appx0087, Appx0134 [’400 Patent, Fig. 24, 18:4-11]. Figure 24 depicts a first string of LEDs 324 having five LEDs connected in series and a second string of LEDs 324 having five LEDs connected in series:

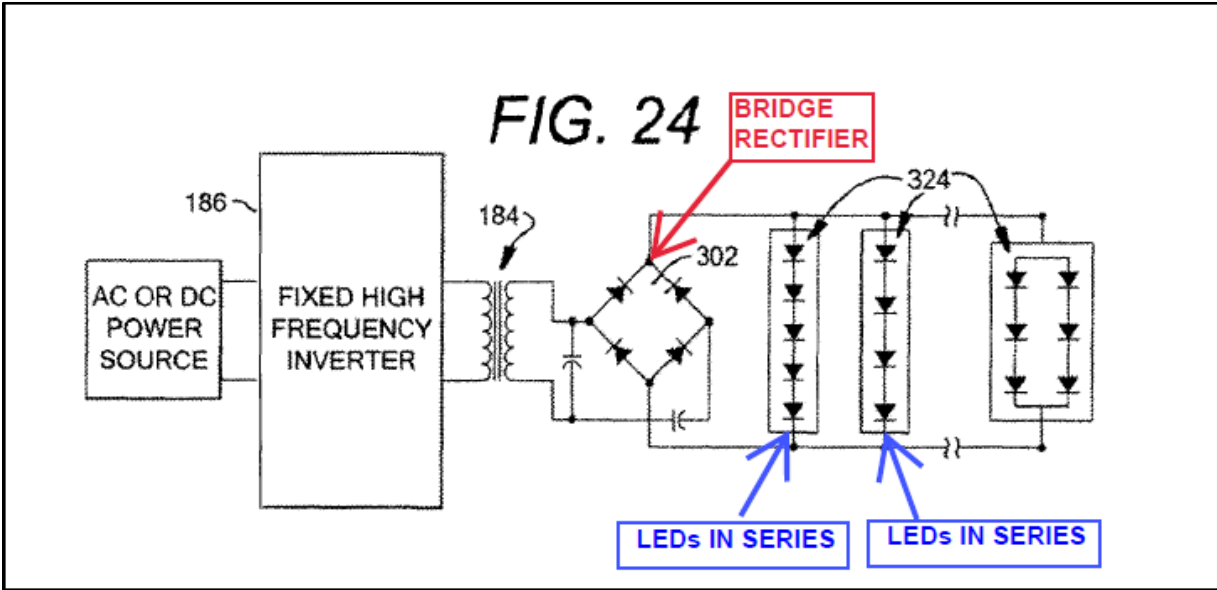

Appx0087 ['400 Patent, Fig. 24] (annotated in red, blue).

See Appx6304 [POR, 4].

B. The Claims of the '400 Patent

Claim 7 of the '400 Patent recites a lighting system including an LED circuit array comprising an LED circuit comprising a plurality of LEDs connected in series, a capacitor, a bridge rectifier with an AC mains voltage input, and a driver connected to the bridge rectifier providing a rectified AC voltage output to the LED circuit array. Claim 7 recites that a forward voltage of the LEDs of the LED circuit array matches the rectified AC voltage output of the driver. Appx0139 ['400 Patent, 27:48-62].

Dependent Claims 8-13 recite other limitations related to the lighting system of Claim 7.

Each of independent Claim 7 and dependent Claims 8-13 defines a lighting system that is novel and nonobvious over the prior art.

II. THE REFERENCES

A. Nerone (U.S. Pat. No. 6,411,045) (Ex. 1032)

Nerone, entitled “Light Emitting Diode Power Supply,” discloses a power supply circuit for an LED array. In Figures 1-3 of Nerone, the power supply circuit delivers AC voltage to the LED array. In Figure 4, the power supply circuit delivers DC voltage to the LED array. Appx2254-2257 [Ex. 1032 (Nerone), Figs. 1-4].

Figure 4 of Nerone depicts a power supply circuit 400 that is identical to the power supply circuit 100 of Figure 1 except for the resonant load circuit 404. The resonant load circuit 404 in Figure 4 is different in that it has a second full-wave bridge rectifier 420 that reconverts the AC current from the switches 120/125 back to DC current/DC voltage delivered by an inductor 430 to the LED load. Appx2260 [Nerone, 5:51-64].

The LED load comprises the four groups 410 of LEDs (group1-group4). Each group 410 has multiple LEDs 415 connected in parallel within the group and no LEDs connected in series within the group. No LEDs are connected in series between groups (e.g., no LED in group1 is connected in series with an LED in group2). Each of the groups 410 is connected in series with the other groups 410:

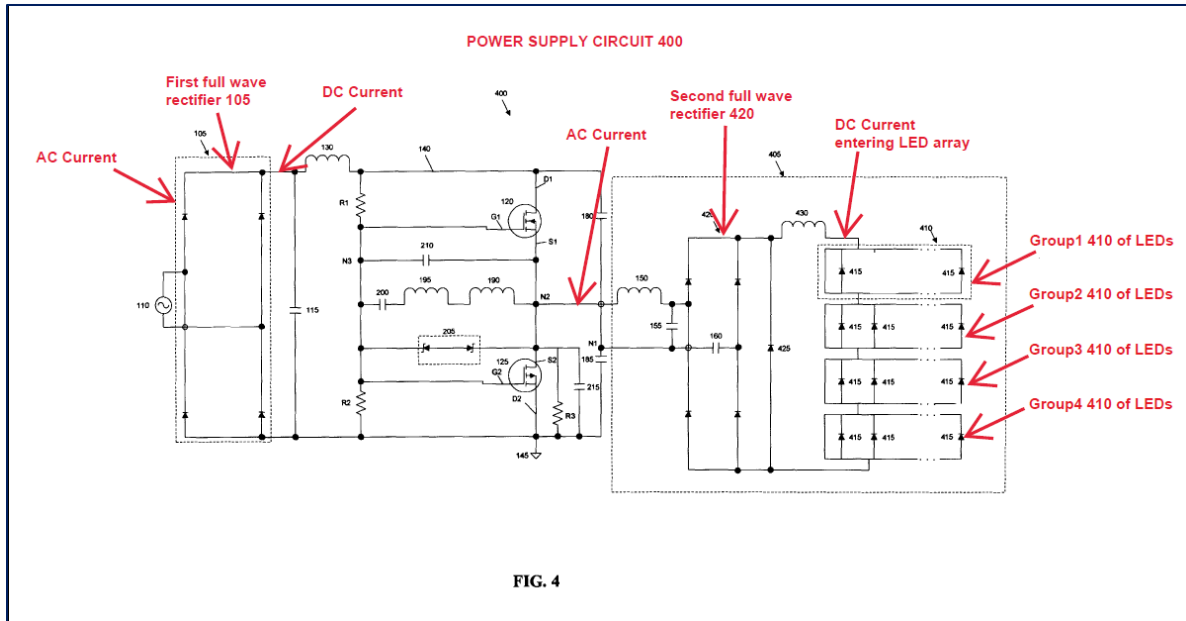

**Appx2257 [Nerone, Fig. 4] (annotated in red).
Appx5273 [Ex. 2001 (Ducharme Decl.), ¶ 60].**

See Appx6310-6311 [POR, 10-11].

Nerone discloses “[t]he groups 410 of the LEDs 415 are connected in series.” Appx2260 [Nerone, 5:59-60]. Thus, the LEDs within each group are connected in parallel only, and only the groups are connected in series. There are no individual LEDs connected in series.

B. Martin (U.S. Pat. Pub. 2004/0206070) (Ex. 1015)

Martin, entitled “Alternating Current Light Emitting Device,” describes a plurality of LEDs connected in series on a single substrate, where the LEDs may be connected directly to an AC voltage source. Appx1867, Appx1876 [Martin, Abstract, ¶ [0005]].

Martin describes that the number of LEDs connected in series should be chosen so that the peak voltage drop from an AC voltage source is less than the total maximum forward voltage of LEDs connected in series. Appx1877 [Martin, ¶ [0022]]. “The number of LEDs is chosen such that the maximum voltage across each individual LED during the peak in the alternating current cycle is low enough so as not to damage the LEDs,” in other words, the peak voltage is less than the “maximum forward voltage of 4.5V” for the LEDs. Appx1877 [Martin, ¶ [0022]]. For LEDs having an individual maximum forward voltage of 4.5 V and an AC source having a 169.7 V peak voltage,¹ Martin teaches the selection of thirty-eight (38) LEDs connected in series. *Id.* The selection of thirty-eight LEDs ensures that the peak value of the AC voltage output is less than the total maximum forward voltage across the LEDs to avoid damage to the LEDs.

III. PROCEDURAL HISTORY

The Petitioner filed the petition (“Petition”) for IPR2022-00149 on November 12, 2021, challenging Claims 7-20. Appx6034-6129 [Pet., 1-96]. The Patent Owner Preliminary Response (“POPR”) was filed on April 11, 2022. Appx6187-6216 [POPR, 1-30]. The Board instituted the IPR with its decision dated July 5, 2022.

¹ Martin has a typo indicating that the AC peak voltage is 180 V. Appx1877 [Martin, ¶ [0022]]. The parties agree that the correct value in Martin for the AC peak voltage is 169.7 V. Appx6314 [POR, 13]; Appx6402 [Reply, 15 n.10] (“It is undisputed that the peak voltage of 120V rms is 169.7V”).

Appx6233-6273 [Instn. Dec., 1-41]. The Patent Owner Response (“POR”) was filed on September 23, 2022. Appx6293-6371 [POR, 1-79]. The POR submitted a statutory disclaimer disclaiming Claims 14 and 18-20. Appx6360 [POR, 65]. The Petitioner filed a reply on December 16, 2022. Appx6386-6423 [Reply, 1-38]. The Patent Owner filed its sur-reply on January 27, 2023. Appx6436-6480 [Sur-reply, 1-35]. The oral hearing was conducted on March 28, 2023. The Board issued its Final Written Decision on June 26, 2023. The Patent Owner timely filed its appeal on August 25, 2023. Appx6566-6571 [NoA, 1-6].

The Petition asserted that Claims 7-20 of the ’400 Patent are unpatentable under thirteen different grounds (Grounds 1-13). Appx6047-6048 [Pet., 4-5]. The Patent Owner’s statutory disclaimer of Claims 14 and 18-20 removed Grounds 8 and 11-13 from the proceeding.

Ground 1 asserted that the combination of Nerone and Martin renders independent Claim 7 and dependent Claims 9 and 11 obvious. Appx6047 [Pet., 4]. The Board determined that Claims 7, 9, and 11 were obvious under this ground. Appx0039-0042 [FWD].

Ground 6 asserted that the combination of Zhang and Martin renders independent Claim 7 and dependent Claims 9-11 and 17 obvious. The Board determined that dependent Claim 17 was obvious. The Board determined that

independent Claim 7 and dependent Claims 9-11 were not obvious under this ground. Appx0053-0057 [FWD].

Ground 7 asserted that the combination of Zhang, Martin, and Morgan renders dependent Claim 8 obvious. The Board determined that Claim 8 was not obvious under this ground. Appx0058 [FWD].

This appeal addresses the Board's finding of unpatentability of independent Claim 7 and dependent Claims 9 and 11 based on Nerone and Martin (Ground 1). See Appx6047 [Pet., 4]. A reversal of the Board's determination in Ground 1 renders Claim 7-13 patentable.

This appeal also addresses the Board's consideration of the Martin reference in Grounds 1-6. The Martin reference is a U.S. patent application published after the priority date of the '400 Patent. A reversal of the Board's decision to apply Martin in Grounds 1-6 renders Claim 7-13 and 17 patentable.

SUMMARY OF THE ARGUMENT

The Board committed three errors in this IPR, each independently requiring reversal. These errors led the Board to hold Claims 7-13 of the '400 Patent unpatentable.

First, the Board erroneously construed “an LED circuit comprising a plurality of LEDs connected in series” in limitation 7(b) to encompass LED circuits or groups of LEDs being connected in series even if no individual LEDs are connected in series with other LEDs. The proper construction requires that a plurality of LEDs, not LED circuits or groups of LEDs, are connected in series.

In arriving at its incorrect construction, the Board failed to apply the ordinary meaning of the claim language and failed to consider other claims providing clear guidance on the meaning of “a plurality of LEDs connected in series” in Claim 7. The Board failed to consider the repeated descriptions in the specification of LEDs connected in series as referring to individual LEDs connected in series one to the other.

Upon *de novo* review, this Court should reverse the Board’s construction of an “LED circuit comprising a plurality of LEDs connected in series.” The proper construction is that a plurality of LEDs are connected in series, with the plurality of LEDs being connected one to another to form a single path for current.

Second, the Board’s construction of “a forward voltage of the LEDs ... matches the [] AC voltage output of the driver” in limitation 7(f) should be reversed. The Board’s construction incorrectly encompasses the driver providing a voltage output that is “less than” the forward voltage of the LEDs. There is no basis in the claim language or the specification for this construction that “matches” means “less than.” In applying *de novo* review, this Court should reverse the Board and hold that “matches” means “is equivalent within manufacturing tolerances to.”

Once either (or both) of those erroneous constructions is corrected, there is no remaining basis for holding Claim 7 obvious. The Court should reverse without remand and hold Claim 7 (and dependent Claims 8-13) patentable over the asserted grounds.

Third, the Board legally erred by holding a secret abandoned U.S. patent application, that published only *after* the challenged patent’s priority date, can be applied as prior art in an IPR. Section 311(b) of the Patent Statute provides that an IPR petition can challenge a patent “only on the basis of prior art consisting of patents or printed publications.”

Because the Martin application published only after the priority date of the challenged ’400 Patent, and never matured into a patent, it is neither a patent nor a prior art printed publication. Grounds 1-5 rely on Martin and therefore are legally

unavailable in this IPR. The Board’s holding otherwise should be reversed without remand.

ARGUMENT

I. STANDARDS OF REVIEW

Obviousness is a legal question based on underlying findings of fact. *Univ. of Strathclyde v. Clear-Vu Lighting LLC*, 17 F.4th 155, 160 (Fed. Cir. 2021). “We review the Board’s legal determination of obviousness de novo and its factual findings for substantial evidence.” *Outdry Technologies Corporation v. Geox S.P.A.*, 859 F.3d 1364, 1367 (Fed. Cir. 2017) (citing *Belden Inc. v. Berk-Tek LLC*, 805 F.3d 1064, 1073 (Fed. Cir. 2015)).

The Federal Circuit reviews legal conclusions *de novo*. *AC Technologies S.A. v. Amazon.com, Inc.*, 912 F.3d 1358, 1364 (Fed. Cir. 2019) (“We consider de novo the Board’s legal conclusions.”); *In re Stepan Co.*, 868 F.3d 1342, 1345 (Fed. Cir. 2017). De novo review is conducted anew, without deference to the Board. *See Motionless Keyboard Co. v. Microsoft Corp.*, 486 F.3d 1376, 1379 (Fed. Cir. 2007).

This Court “review[s] questions of claim construction de novo.” *Qualcomm Inc. v. Intel Corp.*, 6 F.4th 1256, 1266 (Fed. Cir. 2021) (citing *Williamson v. Citrix Online, LLC*, 792 F.3d 1339, 1346 (Fed. Cir. 2015)); *see, e.g., PPC Broadband, Inc. v. Corning Optical Communications RF, LLC*, 815 F.3d 734, 739 (Fed. Cir. 2016).

This Court reviews questions of statutory interpretation *de novo*. *Genentech, Inc. v. Immunex Rhode Island Corp.*, 964 F.3d 1109, 1111 (Fed. Cir. 2020). *Belkin Intern., Inc. v. Kappos*, 696 F.3d 1379, 1381 (Fed. Cir. 2012) (“Statutory interpretation is a question of law that we likewise review *de novo*.”)

II. THE BOARD’S CONSTRUCTION OF LIMITATION 7(b) FOR “AN LED CIRCUIT COMPRISING A PLURALITY OF LEDs CONNECTED IN SERIES” IS LEGALLY ERRONEOUS.

A. Introduction

Limitation 7(b) recites “an LED circuit array comprising an LED circuit comprising a plurality of LEDs connected in series.” Appx0139 [’400 Patent, Cl. 7]. The parties dispute the plain and ordinary meaning of limitation 7(b). Appx6442 [Sur-reply, 1].

The Patent Owner’s construction requires that “at least two LEDs are connected in series.” Appx6443 [Sur-reply, 2]. The Patent Owner explained that “limitation 7(b) refers to **individual LEDs** connected in series, not **individual groups or circuits of LEDs** being [connected] in series” when there are no individual LEDs that are connected in series. Appx6324 [POR, 24] (emph. added). The Patent Owner also explained that “connected in series” means that the LEDs are connected end-to-end to form a single path for current such that the LEDs will always carry the same current. Appx6327 [POR, 27]; Appx6443 [Sur-Reply, 2].

There is no dispute as to the ordinary meaning of components being “connected in series.” The Patent Owner explained that components (e.g., LEDs) connected in series “have the same current path, and thus always carry the same current end to end through the series circuit.” Appx6443 [Sur-reply, 2] (citing Appx5508 [Ex. 2007 (MCGRAW-HILL DICTIONARY OF ELECTRONICS AND COMPUTER TECHNOLOGY), 4]); Appx5287 [Ex. 2001 (Ducharme Decl.), ¶ 83]. *McGraw-Hill* defines components connected in series (*series*: “An arrangement of circuit components end to end to form a single path for current”; *series circuit*: “A circuit in which all parts are connected end to end to form a single path for current”). Appx5287 [Ex. 2007 (McGraw-Hill), 4]. See Appx6327 [POR, 27]. The Board does not dispute this meaning of “connected in series” provided by the Patent Owner. See Appx0019 [FWD]. Nor does the Petitioner or its expert. See Appx6388-6399 [Reply, 1-12]; Appx5058-5100 [Ex. 1107 (Baker Reply Decl.)]; Appx6444 [Sur-Reply, 3].

The Petitioner’s own expert agreed with this common understanding of LEDs being connected in series. Appx5430 [Ex. 2006 (Dep. Trans. Baker), 84:16-18] (“The only way that the two diodes [LEDs] will be in series is if they have the same current flowing, and they’re physically in series.”). See Appx6534 [Hearing Trans., 3/28/2023, 36:20-37:1] (citing same).

Patent Owner provided an example explaining what it means for LEDs to be connected in series pursuant to the undisputed ordinary meaning set forth in *McGraw-Hill*:

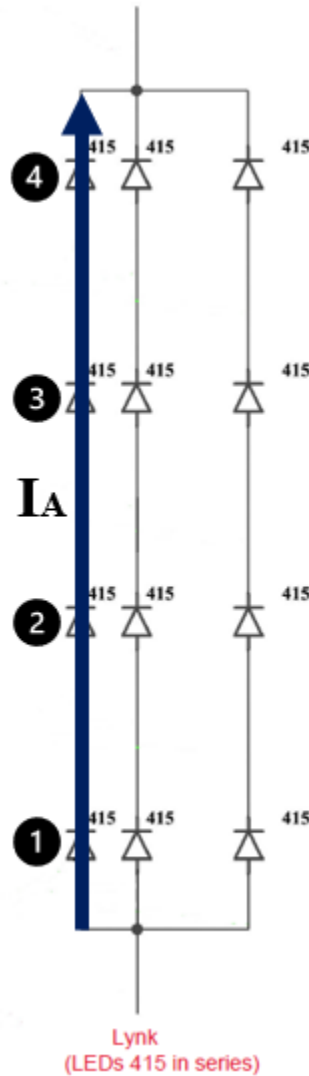

Appx6305 [POR, 25] (excerpted and modified Figure 4 of Nerone, further annotated in black).

In the above figure, the four LEDs (LED1, LED2, LED3, and LED4) are connected in series because they are connected one to the other to form a single path for current labeled I_A . See Appx6327 [POR, 27]; Appx6443 [Sur-Reply, 2].

The Patent Owner also provided a diagram illustrating **groups** of LEDs being connected in series with other groups of LEDs, but where no individual LEDs are connected in series with other LEDs. See Appx6325 [POR, 25]. This example is illustrated on the left below (diagram A):

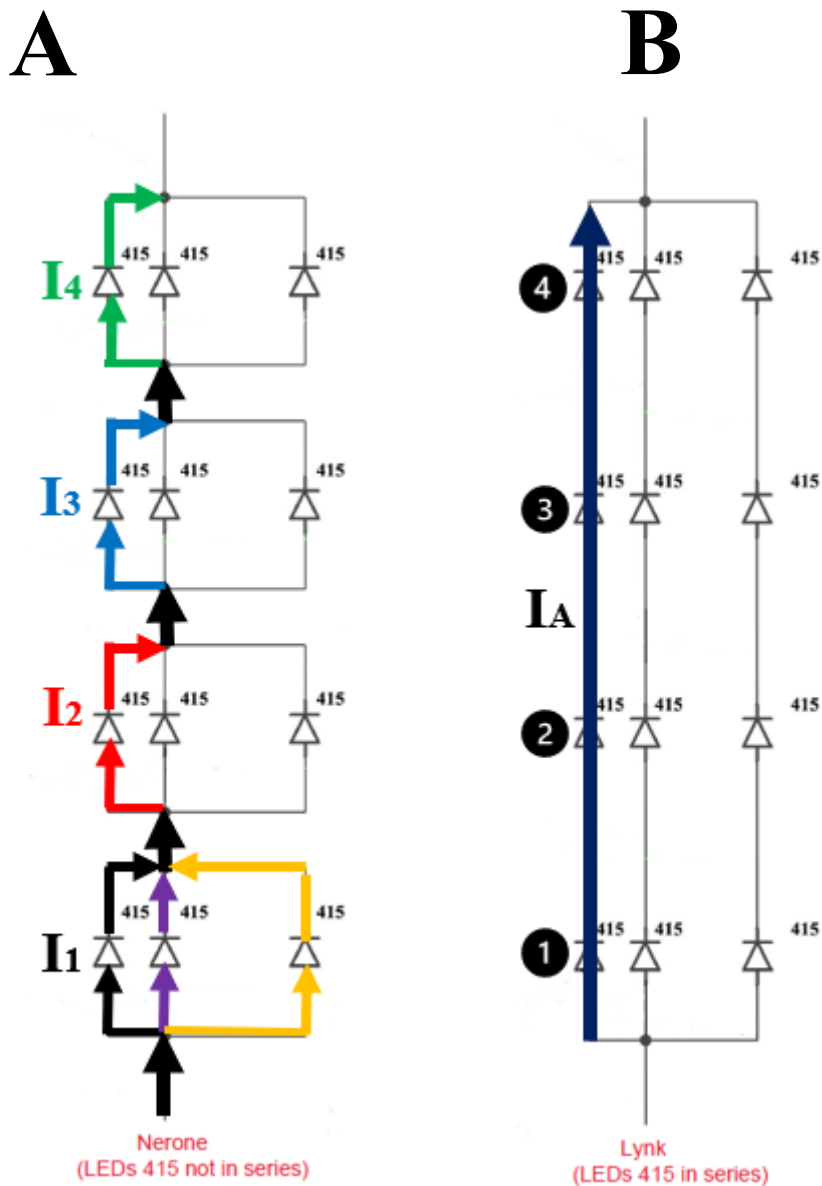

See Appx6325 [POR, 25] (Fig. 4 of Nerone, excerpted and further annotated).

Referring to diagram A, the current entering each group of LEDs² is split among the three LEDs in each group. For example, the current entering the bottom group is divided into three different current paths: a current path in **black**, a current path in **purple**, and a current path in **yellow**. The current path for LED1 is labeled **I₁**. After recombining at the top of the first group of LEDs, the current splits again as it enters the second group of LEDs, with the current path for LED2 being labeled **I₂**. The current path for LED3 is **I₃**, and the current path for LED4 is **I₄**. The Petitioner's own expert agreed that current entering a group of LEDs splits and then it recombines at the output of the group. Appx5368 [Ex. 2006 (Dep. Trans. Baker), 22:3-7].

Diagram A illustrates that the individual LEDs 1-4 are not connected in series because they do not have a single, common current path—they have different current paths (**I₁-I₄**). On the other hand, diagram B illustrates that LEDs 1-4 are connected in series because they are connected end-to-end to have a single, common current path (**I_A**). Diagram A illustrates that while **groups of LEDs** in Nerone may be connected in series with other **groups of LEDs**, there are no **LEDs** that are connected in series with **other LEDs**. Appx6326 [POR, 26].

² In diagram A, there are four groups of LEDs. Each group of LEDs has three LEDs connected in parallel, not in series. See e.g., Appx2257 [Ex. 1032 (Nerone), Fig. 4]; Appx5410 [Ex. 2006 (Dep. Trans. Baker), 64:20-24].

The Board erroneously construed limitation 7(b) as not requiring any LEDs to be connected in series. Appx0022-0024 [FWD]. The Board held that the limitation of “an LED circuit comprising a plurality of LEDs connected in series” encompasses a circuit/group of LEDs connected in series with another circuit/group of LEDs, even when no individual LED is connected in series to another LED to form a single current path. Indeed, the Board explicitly conceded that no individual LEDs in Nerone are connected in series: “We find that any two adjacent groups 410, which are part of the LED circuit in Nerone, correspond, to ‘a plurality of LEDs connected in series,’” notwithstanding “the fact that individual LEDs in any group 415 [*sic*: group 410]³ are **not connected in series.**” Appx0024 [FWD] (emph. added).

B. The Claim Language Demonstrates that the Board’s Construction of “an LED Circuit Comprising a Plurality of LEDs Connected in Series” is Erroneous

The claim construction inquiry starts with the ordinary and customary meaning of the term and focuses on the intrinsic evidence, consisting of (1) the claim language; (2) the specification; and (3) the prosecution history. *Polaris Indus., Inc. v. Arctic Cat, Inc.*, 882 F.3d 1056, 1065 (Fed. Cir. 2018); *Knowles Elecs. LLC v.*

³ The Board inadvertently referred to “group 415” instead of “group 410.” The designator 415 refers to the individual LEDs, and 410 refers to a group of LEDs. Appx2260 [Nerone, 5:57-60] (“The resonant circuit further includes at least one group 410 of LEDs 415 connected in parallel ... The groups 410 of the LEDs 415 are connected in series.”)

Iancu, 886 F.3d 1369, 1373-74 (Fed. Cir. 2018). Extrinsic evidence such as technical dictionaries can be helpful in ascertaining the meaning of a claim term to those skilled in the art, provided the extrinsic evidence does not contradict the intrinsic evidence. *Phillips v. AWH Corp.*, 415 F.3d 1303, 1317-1318 (Fed. Cir. 2005) (“We have especially noted the help that technical dictionaries may provide ... the way in which one of skill in the art might use the claim terms.”).

1. The plain language of limitation 7(b) contradicts the Board’s construction.

The point of departure for the claim construction inquiry is the claim language itself. *Phillips*, 415 F.2d at 1314. See *Vitronics Corp. v. Conceptronic, Inc.*, 90 F.3d 1576, 1582 (Fed. Cir. 1996) (“First, we look to the words of the claims themselves, both asserted and nonasserted, to define the scope of the patented invention.”).

Limitation 7(b) has a structure with three layers: an LED circuit array, an LED circuit, and a plurality of LEDs. Appx0139 [’400 Patent, Cl. 7 (27:49-50)]. The limitation defines relationships between the three layers: (1) there is an LED circuit array that comprises an LED circuit; (2) the LED circuit comprises a plurality of LEDs; and (3) the plurality of LEDs are connected in series. A POSITA would readily understand that it is the “plurality of LEDs” that are connected in series. Appx5284-5285 [Ex. 2001 (Ducharme Decl.), ¶ 78].

Additionally, the phrase “connected in series” modifies “plurality of LEDs,” not “LED circuit” or “LED array” which are recited as different claim elements.

Appx0139 [’400 Patent, 27:49-50]. It thus defines a relationship between the plurality of LEDs—they are “connected in series.” It does not define a relationship between LED circuits. Indeed, the claim could not be understood as defining a relationship between LED circuits because it only recites a single LED circuit (“an LED circuit”).

The Board’s construction disregards the claim language providing for “an LED circuit comprising a plurality of LEDs connected in series,” improperly rewriting it as “an LED circuit comprising a plurality of **LED circuits** connected in series” or “an LED circuit comprising a plurality of **groups of LEDs** connected in series.” However, the claim distinguishes between the “LED circuit” and the “plurality of LEDs.” Appx0139 [’400 Patent, Cl. 7, 27:49-50]. The claim provides that the “plurality of LEDs” are connected in series, not the “LED circuit” or “LED circuits.” Appx6443 [Sur-reply, 2]. The Board never addressed this point in the FWD. The applicant could have drafted the claim to recite that LED circuits are connected in series, such as: “a plurality of LED circuits connected in series.” Appx6324 [POR, 24]. The applicant could have drafted the claim to recite: “an LED circuit array comprising a plurality of LED circuits connected in series, each LED circuit comprising a plurality of LEDs.” Or the claim could have recited: “a plurality of groups of LEDs connected in series.” But the claim does not say any of these things. The claim was drafted to provide that the “LEDs”—not “LED circuits” or “groups

of LEDs”— are connected in series. The Board’s construction is erroneous as a matter of law on *de novo* review. *Qualcomm Inc. v. Intel Corp.*, 6 F.4th 1256, 1266 (Fed. Cir. 2021) (citing *Williamson v. Citrix Online, LLC*, 792 F.3d 1339, 1346 (Fed. Cir. 2015)). The Board’s construction is directly contrary to the claim language and is thus reversible error. *Ultratec, Inc. v. CaptionCall, LLC*, 872 F.3d 1267, 1273, 1275 (Fed. Cir. 2017).

The Board’s construction also improperly reads “plurality of LEDs connected in series” out of the claim because its construction does not require a single LED to be connected in series with another LED. See Appx0024 [FWD]. The Board’s construction thus rewrites the limitation to broaden its scope so that it encompasses “LED circuits connected in series” and “groups of LEDs connected in series” even in the absence of LEDs connected in series. See *Maxwell v. J. Baker, Inc.*, 86 F.3d 1098, 1105 (Fed. Cir. 1996) (improperly broadening scope of claims); *Unique Concepts, Inc. v. Brown*, 939 F.2d 1558, 1563 (Fed. Cir. 1991) (claim not to be construed to remove limitation).

2. The language used in other claims in the ’400 Patent demonstrates the Board’s construction is erroneous.

It is well established that the meaning of a claim can be discerned by reference to other claims in the patent. *Phillips*, 415 F.3d at 1314. The claims of the ’400 Patent recite various relationships in circuits. For example, an element may be “connected

in series” with another element, or an element may be “connected in parallel” with another element. See Appx0139 [’400, Cl. 7 (27:49-50)] (“connected in series”), Claim 14 (28:15) (“connected in parallel”). The element at issue could be a single LED or it could be an LED circuit. For example, Claim 14 of the ’400 Patent recites a relationship between LED circuits: “a plurality of LED circuits connected in parallel ... wherein each LED circuit comprises at least two LEDs.” Appx0139 [’400 Patent, Cl. 14, 28:15-16]. See Appx0428 [Ex. 1004 (Prosecution History), 40] (original Claim 14). Claim 14 thus defines a relationship between a plurality of **LED circuits**.⁴ Claim 7, on the other hand, defines a relationship between a plurality of **LEDs**, not LED circuits. Claim 14 confirms the meaning of the applicant’s choice of language: Claim 7 provides that the **LEDs** are “connected in series,” not that the LED circuits or the groups of LEDs are connected in series.⁵

The Board misapprehended the significance of the choice of language in Claim 7 versus Claim 14, asserting without explanation that the comparative language “sheds little, if any light” on claim construction. Appx0023 [FWD]. The Patent

⁴ The LED circuits are groups of LEDs because each LED circuit “comprises at least two LEDs.”

⁵ The Board asserts that the Patent Owner is rewriting the claim as “plurality of individual LEDs connected in series.” Appx0023 [FWD]. That is not the case. The Patent Owner refers to “individual” simply to illustrate the point that the claim recites that “LEDs”—not “LED circuits” or “groups of LEDs”—are “connected in series.”

Owner respectfully submits that the comparative language confirms the plain meaning of Claim 7, which is that LEDs are connected in series with other LEDs.⁶

C. The Specification of the '400 Patent Confirms that the Board's Construction is Erroneous

Phillips held that the patent specification is the primary source for ascertaining the meaning of the claims, always highly relevant, the single best guide to claim construction analysis, and is usually dispositive. *Phillips*, 415 at 1315. The specification of the '400 Patent is dispositive of the proper construction of limitation 7(b).

The Board did not (because it could not) cite to anything in the '400 Patent specification supporting its construction that “an LED circuit comprising a plurality of LEDs connected in series” encompasses a plurality of LED circuits being connected in series, or a plurality of groups of LEDs connected in series, without there being a single LED connected in series with another LED. Appx0015-0025 [FWD].

The '400 Patent discloses that individual **LEDs** can be connected in series, parallel, or opposing parallel. The '400 Patent also discloses that **LED circuits**

⁶ For avoidance of doubt, the proper construction is that there must be a plurality of LEDs connected in series. The claim is open format. The limitation does not exclude LED circuits or groups of LEDs being connected in series, provided that the requirement is satisfied that there are a plurality of LEDs connected in series.

(groups of LEDs) can be connected in series, parallel, or opposing parallel. Those two things are not the same. See Appx0139 [’400 Patent, Cl. 1] (“LEDs connected in series, parallel, or opposing parallel”) (27:22-23), Cl. 7 (“LEDs connected in series”) (27:50), Cl. 14 (“**LED circuits** connected in parallel, wherein each LED circuit comprises at least two LEDs”) (28:15-16), Cl. 21 (“at least two LEDs connected in series, parallel or opposing parallel”) (28:42-44). See Appx6389 [Reply, 2] (citing Cl. 1, 21); Appx6324 [POR, 14] (citing Cl. 14).

Figure 16 of the ’400 Patent discloses **individual LEDs** being connected **in series**. Appx6444 [Sur-reply, 3]. There are seven LEDs connected in series. The seven LEDs are connected in series because each LED is connected to the next LED such that they have a single path for current (like current flowing through a single wire), as indicated by the blue arrow:

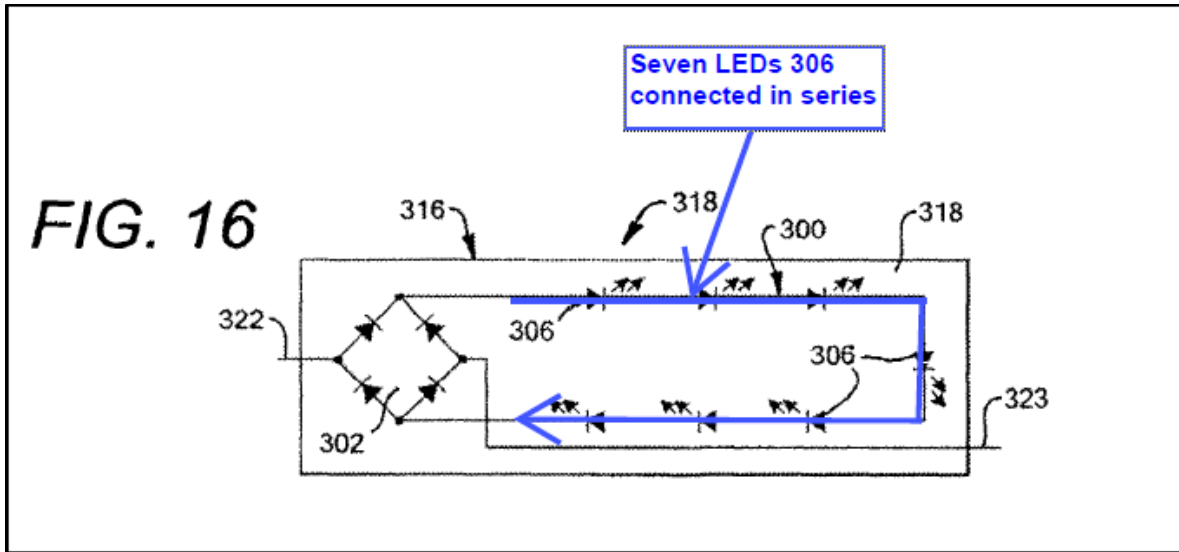

Appx0082, Appx0133, [’400 Patent, Fig. 16 (annotated in blue), 16:21-23]
(“the device 316 includes the device 300 as disclosed in FIG. 15 (with additional LEDs 306 added in series ...”).

See Appx6444 [Sur-reply, 3] (citing Appx0082, Appx0133 [’400 Patent, Fig. 16, 16:23]). See also Appx0082, Appx0133 [’400 Patent, Fig. 17 (seven LEDs connected in series), 16:50-51] (“multiple LEDs connected in series” in Figure 17). See Appx6444 [Sur-reply, 3].

Figure 18 of the ’400 Patent depicts a circuit with thirteen individual LEDs connected in series:

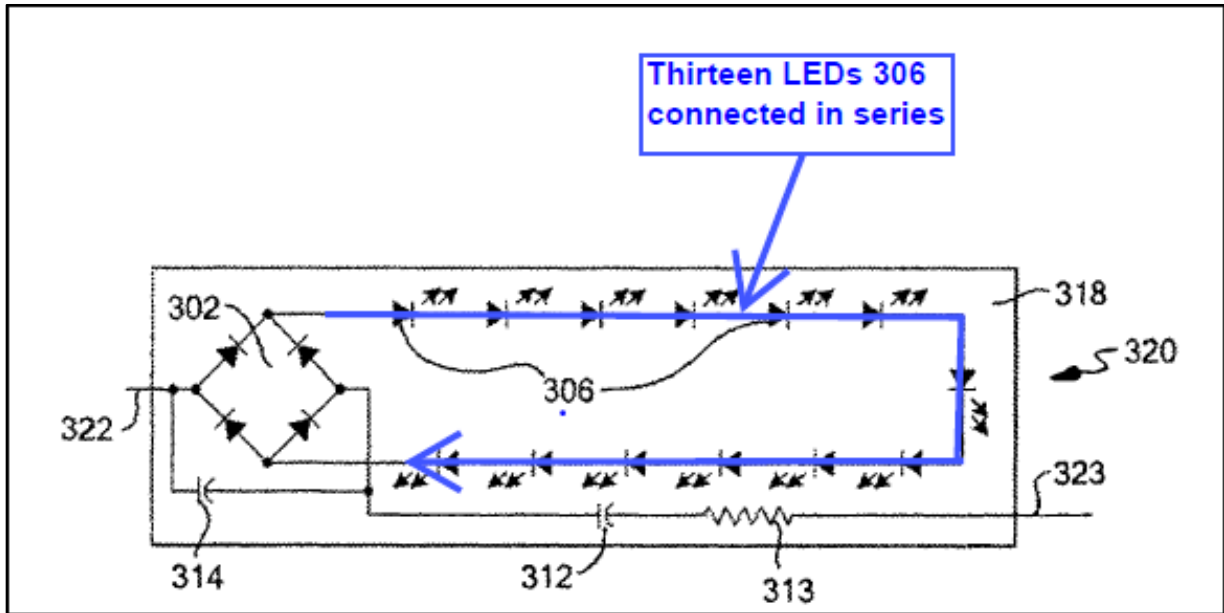

Appx0083, Appx0133 [’400 Patent, Fig. 18 (annotated in blue), 16:22-23] (“with additional LEDs 306 added in series”).

The thirteen LEDs are connected in series because each LED is connected to the next LED such that they have a single path for current, as indicated by the blue arrow.

Figure 8 of the ’400 Patent illustrates the distinction between groups of LEDs being connected in a particular configuration and individual LEDs connected in a particular configuration. Figure 8 discloses individual LEDs connected in series, as well as groups of LEDs connected in parallel. In Figure 8, the first group of LEDs (Group 1) is connected in parallel to the second group of LEDs (Group 2):⁷

⁷ The configuration is referred to as “opposing” parallel because the two groups of LEDs have opposing polarity. This is not a matter of dispute.

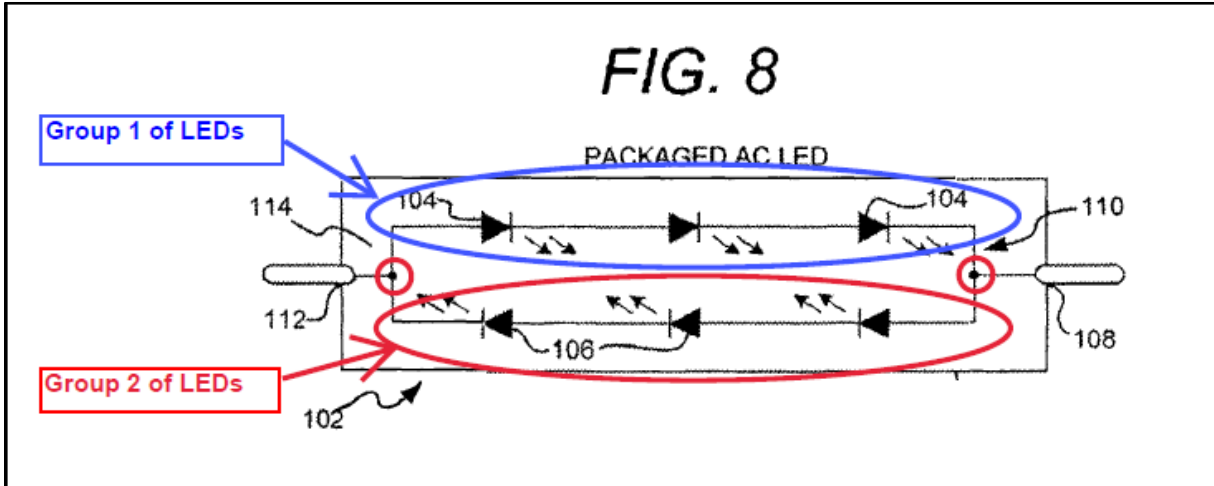

Appx0080, Appx0133 [’400 Patent, Fig. 8, (annotated in red and blue), 15:15-17] (“a first series string of LEDs 104 [Group 1] connected to a second series string of LEDs 106 [Group 2] in opposing parallel configuration”).

See Appx6446-6447 [PO Sur-reply, 5-6].

Figure 8 also depicts **individual LEDs** connected in series with other LEDs. Referring to the annotated Figure 8 below, the top of the diagram (blue) depicts three individual LEDs 104 connected in series in a first series string. The bottom of the diagram (red) depicts three individual LEDs 106 connected in series in a second series string. In each string, the individual LEDs are connected one to the other so they form a single path for current (as indicated by the blue and red arrows).

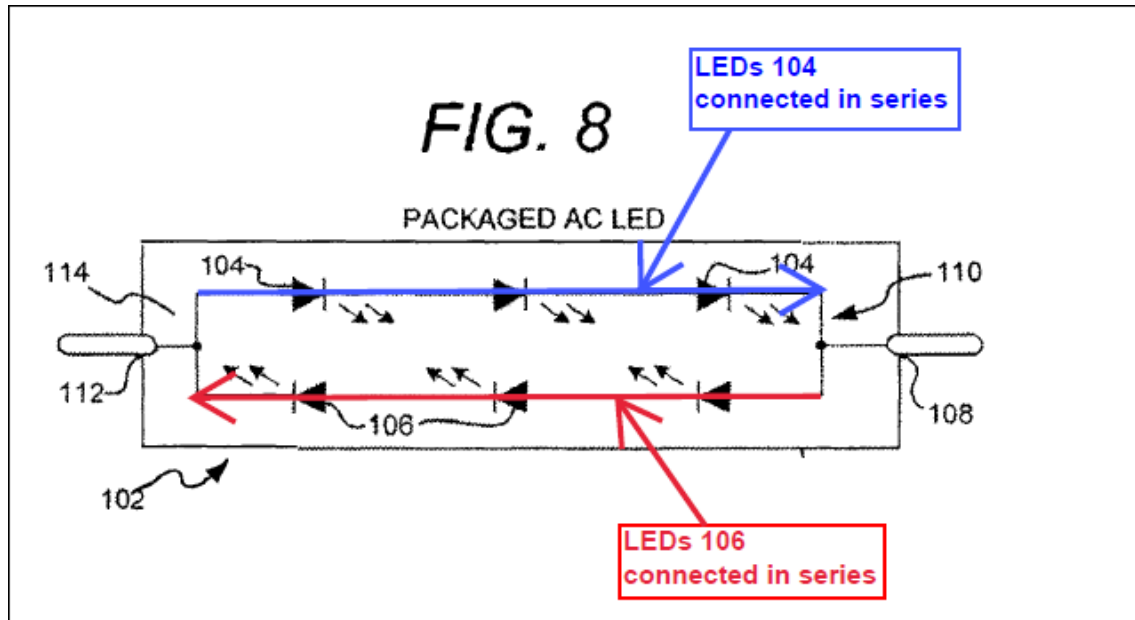

Appx0080, Appx0133 [’400 Patent, Fig. 8 (annotated in red, blue), 15:15-16] (“a first series string of LEDs 104,” “a second series string of LEDs 106”).

See Appx6446-6447 [Sur-reply, 5-6].

The Patent Owner explained that “an LED circuit comprising a plurality of LEDs connected in series” is supported by Figure 8. Appx6447 [Sur-reply, 6]. This is because Figure 8 discloses a circuit “comprising a plurality of LEDs connected in series” (i.e., the first string of LEDs 104 connected in series and/or the second string of LEDs 106 connected in series). The fact that Figure 8 also depicts that two groups of LEDs (the two strings) are connected in parallel does not disturb that conclusion. This puts to rest the Petitioner’s incorrect assertion that the Patent Owner’s

construction improperly excludes parallel connections involving LEDs. Appx0020 [FWD]; Appx6389 [Reply, 2].⁸

The Board cited Figure 22 in its final decision. See Appx0004 [FWD].⁹ Figure 22 is another disclosure of a plurality of LEDs connected in series. In Figure 22, there is a first string of five LEDs connected in series in the first circuit 316 (blue) and no LEDs in parallel, and a second string of five LEDs connected in series in the second circuit 316 (red) and no LEDs in parallel. In Figure 22, the first circuit 316 (first group of series-connected LEDs) and the second circuit 316 (second group of series-connected LEDs) are connected in parallel to each other. Limitation 7(b) is supported by Figure 22 because it includes an LED circuit comprising a plurality of LEDs connected in series (i.e., the series of five LEDs in the first circuit and/or the

⁸ The Petitioner's argument on reply that Figure 8 and other figures having parallel connections would be excluded by the Patent Owner's construction is wrong. Figure 8 and other figures including parallel connections support Claim 7 because they include LEDs connected in series. See, e.g., Appx0084 ['400 Patent, Fig. 21] (plurality of circuits 178, 180, 182 are in parallel; claim reads on Figure 21 because it includes circuit 180 with three LEDs connected in series). See Appx6447 [Sur-reply, 6].

⁹ The Board cited Figure 14 of the '697 Patent in its decision. Appx0020-0021 [FWD]. Like Figure 8, limitation 7(b) is supported by Figure 14 because it discloses a plurality of LEDs connected in series. However, the assertion that redrawn Figure 14 of the '697 Patent is "functionally identical" to Nerone's Figure 4 (see Appx0021 [FWD], figure at top) is misplaced. They are materially different. Figure 14 of the '697 Patent has groups of LEDs in **opposing polarity**, whereas the groups 410 of LEDs in Nerone are in **aligned polarity**. The circuits operate in completely different manners.

series of five LEDs in the second circuit). The Board agreed that Figure 22 discloses a “circuit comprising a plurality of LEDs connected in series.” Appx0004 [FWD] (“device 316 includes plural LEDs 306 connected in series”).

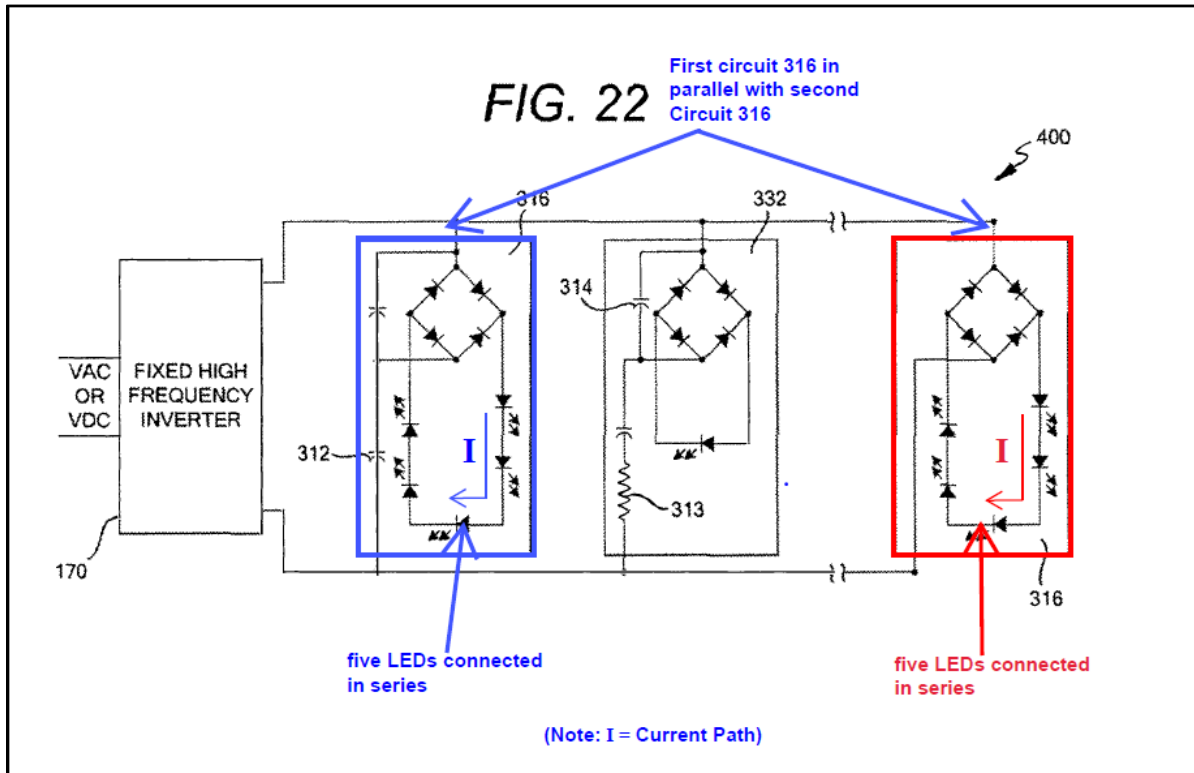

Appx0085 [’400 Patent, Fig. 22, (annotated in red, blue)].

The specification’s differentiation between (1) groups of LEDs (e.g., LED circuits) connected in series and (2) individual LEDs connected in series is further confirmed by Figure 65. Figure 65 depicts a plurality of circuits 2193, each having an LED. There are six circuits 2193 connected in series, as depicted in the annotated figure below. The specification of the ’400 Patent does not describe this configuration as having **LEDs** connected in series. Instead, the specification

discloses that the circuits 2193 are connected in series with the other circuits 2193.

Appxp138 ['400 Patent, 26:21-23].

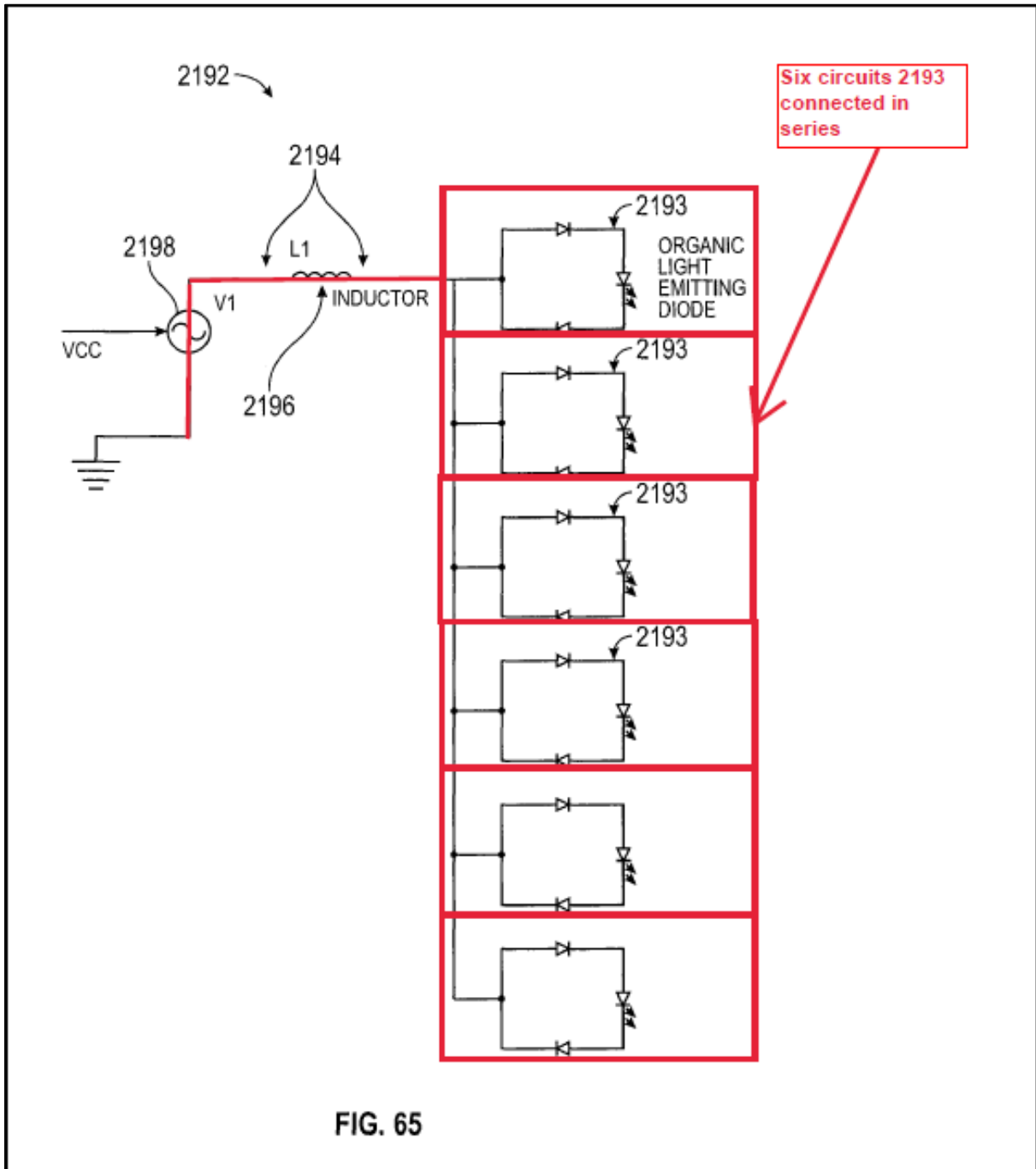

Appx0122 ['400 Patent, Fig. 65] (annotated in red).

See also Appx0121 [’400 Patent, Fig. 64] (circuits 2191 having LEDs connected in series with other circuits 2191).

Therefore, the ’400 Patent repeatedly and consistently characterizes LEDs connected in series as meaning individual LEDs connected end to end such that they form a single path for current. The specification distinguishes between **individual LEDs** connected in series and **groups of LEDs** connected in series, just like Claims 1, 7, 14, and 21 of the ’400 Patent.

The proper construction based on the existing record is clear. *Qualcomm Inc. v. Intel Corp.*, 6 F.4th 1256, 1266 (Fed. Cir. 2021) (cite omitted). The specification repeatedly and consistently characterizes LEDs connected in series as being individual LEDs being connected one to the other to form a single path for current, and distinguishes that from groups of LEDs connected in series with other groups of LEDs. *GPNE Corp. v. Apple Inc.*, 830 F.3d 1365, 1370 (Fed. Cir. 2016) (quoting *VirnetX, Inc. v. Cisco Sys., Inc.*, 767 F.3d 1308, 1318 (Fed. Cir. 2014)); *Phillips*, 415 F.3d at 1321 (specification acting as a dictionary through consistent usage); *Irdeto Access, Inc. v. Echostar Satellite Corp.*, 383 F.3d 1295, 1300 (Fed. Cir. 2004).

The Board’s overly broad construction of limitation 7(b) as encompassing groups of LEDs connected in series with other groups without there being any individual LEDs connected in series should be reversed. The proper construction is that a plurality of LEDs are connected to each other in series, meaning that the LEDs

are connected end-to-end to form a single path for current. This Court should reverse without remand because the claim construction issue is dispositive of validity. *See Personalized Media Communications, LLC v. Apple Inc.*, 952 F.3d 1336, 1346 (Fed. Cir. 2020) (reversal without remand where Board determination of patentability was predicated on erroneous claim construction).

III. INDEPENDENT CLAIM 7 AND DEPENDENT CLAIMS 8-13 ARE PATENTABLE WHEN THE PROPER CLAIM CONSTRUCTION IS APPLIED FOR LIMITATION 7(b)'s "AN LED CIRCUIT COMPRISING A PLURALITY OF LEDs CONNECTED IN SERIES".

The Board determined that Nerone met limitation 7(b) only because it discloses that groups 410 of LEDs are connected in series with other groups 410 of LEDs, even though no individual LED is connected in series with another LED.

A. The Board's Determination Was Based on Nerone's Disclosure that Each Group 410 of LEDs Is In Series With the Other Groups 410

The Board found that limitation 7(b) was met based on Nerone's disclosure that the groups of LEDs are connected in series: "The **groups 410** of the LEDs 415 **are connected in series.**" Appx2260 [Nerone, 5:59-60] (emph. added). See Appx0024 [FWD] ("To be clear, we find that Nerone discloses that resonant load circuit 405 'includes at least one group 410 of LEDs 415 ...and 'groups 410 of the LEDs 415 *are connected in series.*'") (original italics). The Board added: "We find that any two adjacent groups 410, which are part of the LED circuit in Nerone, correspond, to 'a plurality of LEDs connected in series'" notwithstanding "[t]he fact that

individual LEDs in any group [410] ... are not connected in series.” Appx0024 [FWD].

Accordingly, the Board’s determination was based on its erroneous construction that limitation 7(b) encompasses groups of LEDs being connected in series with other groups of LEDs even though no single LED is connected in series with another LED. For this reason, this Court should reverse the Board’s determination that Claim 7 (and dependent Claims 8-13) are unpatentable.

B. The Board Made No Finding That Any Single LED in Nerone Is Connected In Series With Another LED, And There Is No Evidence of Record To Support Such a Finding

The Board, correctly, did not find Nerone discloses individual LEDs connected in series. The Board’s decision did not cite any evidence that Nerone discloses any single LED being connected in series with another LED. See Appx0015-0025 [FWD]. For example, the Board referenced the Patent Owner’s annotation of Nerone’s Figure 4. See Appx0017 [FWD]. Figure 4 of Nerone from the POR is presented below, along with its equivalent on the right hand side:

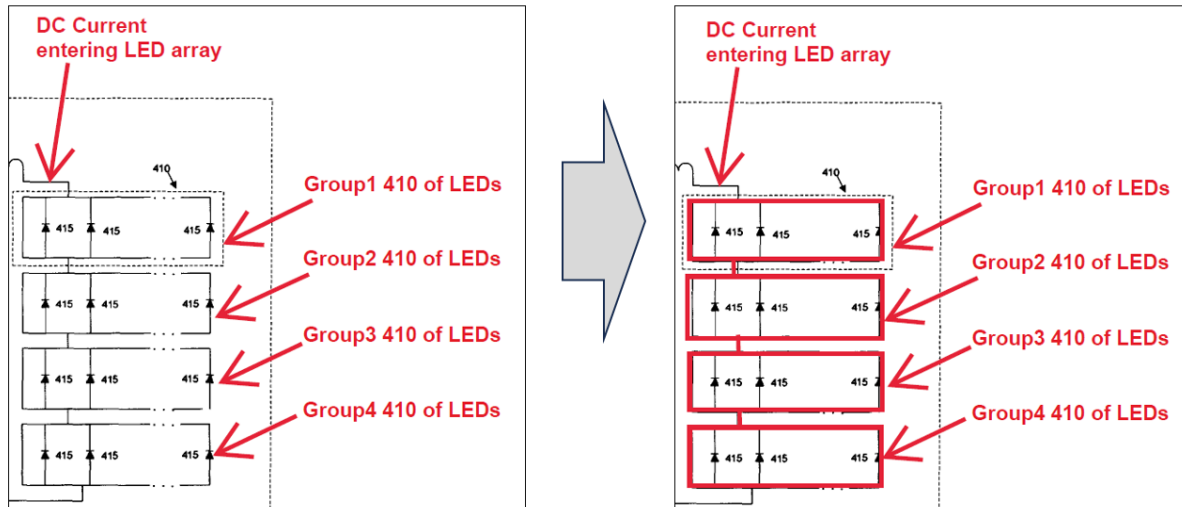

**Appx2257 [Nerone, Fig. 4 (excerpted, annotated in red)];
see Appx6317 [POR, 17]; Appx6449 [Sur-Reply, 8].**

The figure on the right hand side is enlarged below for the convenience of the Court:

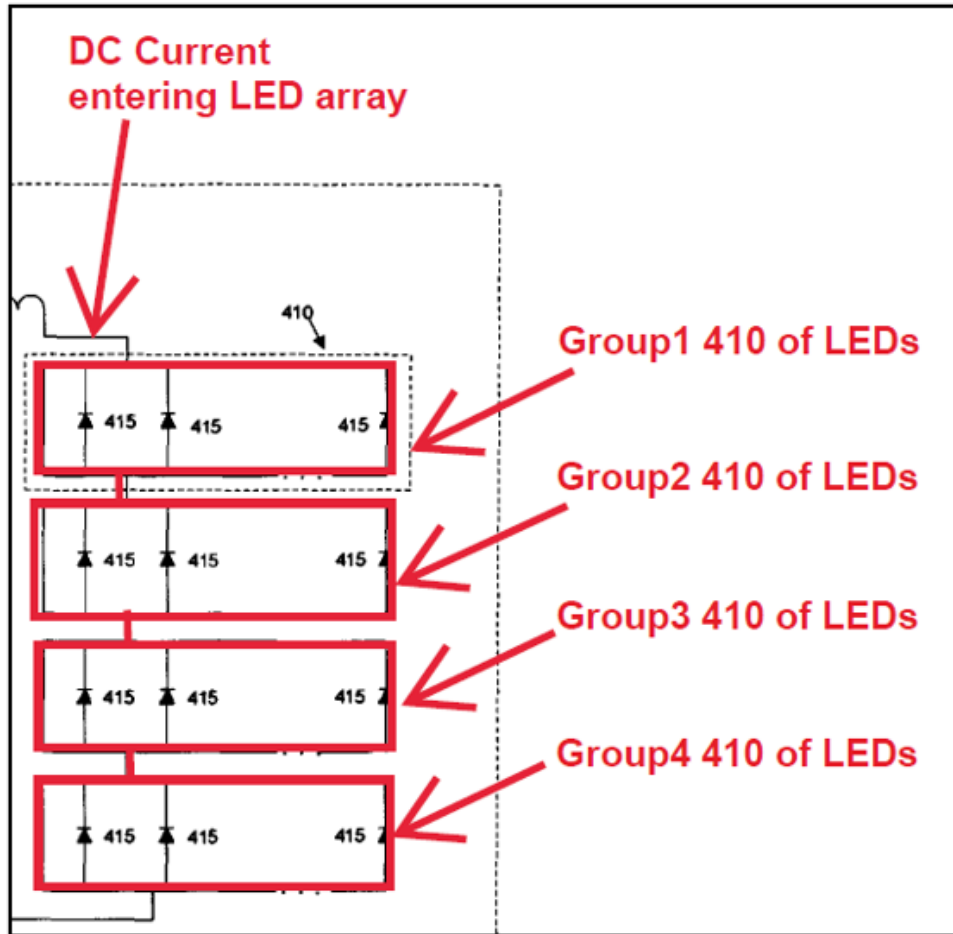

Appx2257 [Nerone, Fig. 4] (excerpted, annotated in red).

The Board found that Group1 is in series with the other groups Group2, Group3, and Group4. That the groups themselves are connected in series is reflected by the red box around each group and the red line connecting adjacent groups. As noted above, the Board did not find that any individual LED 415 is connected in series with another LED 415. Appx0015-0025 [FWD]; Appx6326 [POR, 26]; Appx6449 [Sur-reply, 8]; Appx5287 [Ex. 2001 (Ducharme Decl.), ¶¶ 81-82].

Indeed, the Petition did not provide any evidence that any single LED 415 is connected in series with another LED in Nerone. See Appx6054-6055 [Pet., 11-12].

The Petitioner’s reply provides confirmation, arguing that “[t]he groups 410 of the LEDs 415 **are connected in series**”—not that any LED is connected in series with another LED, as required by limitation 7(b). See Appx6388 [Reply, 1] (orig. emph.).

Under cross-examination, the Petitioner’s own expert explicitly admitted Nerone does not disclose two LEDs (“diodes”) in series:

The first **group** is in series with the second **group**, but if you focus on one LED alone and forget the other ones, the only way that the two diodes will be in series is if they **have the same current flowing and they’re physically in series**. *But* in Nerone what is taught is the **groups** of LEDs 410 **are in series**.

Appx5430 [Ex. 2006 (Baker Dep. Trans.), 84:14-19] (emph., italics, underscore added).

Accordingly, this Court should reverse the Board’s determination regarding Claim 7 without remand and find that the Petitioner failed to prove unpatentability of Claim 7 (and dependent Claims 8-13).

IV. THE BOARD’S CONSTRUCTION OF “FORWARD VOLTAGE OF THE LEDs OF THE LED CIRCUIT ARRAY MATCHES THE RECTIFIED [] AC VOLTAGE OUTPUT OF THE DRIVER” IN LIMITATION 7(f) IS LEGALLY ERRONEOUS.

A. Introduction

Limitation 7(f) of independent Claim 7 recites that “a forward voltage of the LEDs of the LED circuit array matches the rectified [] AC voltage output¹⁰ of the

¹⁰ Limitation 7(f) refers to the “rectified input AC voltage output of the driver.” The parties agree that this refers to the “rectified output AC voltage” of the driver set

driver.” Appx0139 [’400 Patent, Cl. 7]. The Patent Owner treated the language per its plain and ordinary meaning, which is that the value of the total forward voltage of the LEDs is equivalent to the value of the rectified voltage output of the driver. Appx6531 [Hearing Trans., 3/28/2023, 33:12-13] (Patent Owner: “a POSITA would understand that matching means an equivalence within a manufacturing tolerance”).

The ground at issue for Claim 7 involves the combination of Nerone (Ex. 1032) with Martin (Ex. 1015). Appx6047, 6061-6070 [Pet., 4, 18-27]. The Petitioner concedes that Nerone does not meet the “matches” requirement and thus relies on Martin to meet limitation 7(f). Pet., 18-19. The problem with Martin is that rather than teaching that the driver’s voltage output matches the total forward voltage of the LEDs, Martin teaches that the driver’s voltage output is **less than** the forward voltage of the LEDs. Appx1877 [Martin, ¶ [0022]] (selecting thirty-eight LEDs so that the peak driver voltage output is less than the total maximum forward voltage); Appx6333-6334 [POR, 33-34]; Appx6063 [Pet., 20] (voltage delivered by the driver “is low enough”); Appx6401 [Reply, 14] (voltage is “low enough so as not to damage the LEDs” by being less than maximum forward voltage of each LED), Appx6402 [Reply, 15] (peak driver voltage output is less than “maximum forward voltage of 4.5V” for each LED).

forth in the previous limitation (limitation 7(e)). The Petitioner’s expert agreed. Appx0243 [Ex. 1002 (Baker Decl.), ¶ 119].

The Board recognized that Martin teaches the driver's voltage output is configured to be **less than** the forward voltage of the LEDs. Appx0031 [FWD]. When it came to construing "matches," Board conveniently found that it "also encompasses 'the rectified [] AC voltage output of the driver' that is **less than** 'a forward voltage of the LEDs of the LED circuit.'" Appx0036 [FWD] (emph. added). In short, the Board construed "matches" to encompass "less than" in addition to "equals." Upon *de novo* review, the Board's construction is incorrect.

B. The Claim Language Demonstrates that the Board's Construction Is Erroneous

The ordinary meaning of "matches" in the context of the design of LED lighting circuits is "equivalence." This common understanding is supported by the specification as discussed, *infra*. This understanding is explicitly acknowledged by the Board. Appx0036 [FWD] ("equivalence"). This is consistent with the claim language, which recites that the forward voltage of the LEDs "matches" the driver's rectified voltage output. Appx0139 ['400 Patent, 27:57-59].

C. The Specification of the '400 Patent Confirms that the Board's Construction is Erroneous

The Board determined that "matches" is broader than its ordinary meaning because it further encompasses "less than." Appx0036 [FWD] (citing Appx0126 ['400 Patent, 2:32-25]). The Board's justification for its redefinition of the term is based on a single statement in the background of the invention section of the '400

Patent. Appx0036 [FWD] (citing Appx0126 [’400 Patent, 2:32-25]). The cited passage describes a reference named Allen, and is reproduced below:

Allen discloses that for the forward voltage to be “matched,” in each series block, the peak input voltage must be less than or equal to the sum of the maximum forward voltages for each series block in order to prevent over-driving.

Appx0136 [’400 Patent, 2:31-35].

The inventor of the ’400 Patent is not defining “matches” or “matched” here. The placement of quotation marks around the term (“matched”) does not indicate the term is being defined by the inventor. Quite the opposite. A POSITA would understand the inventor is quoting the language from Allen,¹¹ not setting forth a definition for “matches” for the ’400 Patent. The inventor does not come close to “clearly set[ting] forth a definition of the disputed claim term” and “clearly express[ing] an intent to define the term.” *Pacing Technologies, LLC v. Garmin Intern., Inc.*, 778 F.3d 1021, 1024 (Fed. Cir. 2015) (citing *Thorner v. Sony Computer Entm’t Am LLC*, 669 F.3d 1362, 1365 (Fed. Cir. 2012)).

While myopically focusing on one sentence in the background of the invention section, the Board’s construction contradicted the remainder of the specification. The specification of the ’400 Patent does not evince any effort by the inventor to act

¹¹ In other words, the inventor use “scare quotes” to indicate disagreement with Allen’s use of “matched” to refer to less than.

as a lexicographer to redefine “matches” from its ordinary meaning. On the contrary, the specification provides concordance for the ordinary meaning of the term in this art. For example, the ’400 Patent states:

Another form of the invention is an LED lighting system comprising an LED circuit array having a plurality of different LED circuits each drawing the same or different currents, each having the same or different **forward operating voltages**, and each delivering the same or different lumen outputs that may be the same or different colors and an LED circuit driver coupled to the LED circuit array. The LED circuit driver delivering a relatively fixed frequency and voltage output allows for mixing and **matching** of LED circuits requiring **different forward voltages** and drive currents.

Appx0130 [’400 Patent, 10:26-36] (emph. added). This passage does not redefine “matches.”

Significantly, the ’400 Patent discloses that the number of LEDs can be selected so that the total forward voltage across the LEDs matches (equals) the voltage output of the driver:

Regardless of whether rectifier 302 and LEDs 306 are integrated or mounted in a single package or are discretely packaged and connected, in order to drop higher voltages any number of LEDs may be connected in series or parallel in a device to **match a desired voltage** and light output. For example, in a lighting device that is run off of a 120 V source and contains LEDs having a forward operating voltage of 3V each connected to a bridge rectifier having diodes also having a forward operating voltage of 3V each, approximately 38 LEDs may be placed in series to drop the required voltage.

Appx0133-0134 [’400 Patent, 16:64-17:7] (emph. added). See Appx6304-6305 [POR, 4-5]. This passage does not redefine “matches.”

In this passage, the voltage output of the driver after the bridge rectifier (which has two diodes) is $120\text{ V} - (2 * 6\text{ V}) = 114\text{ V}$. The total forward voltage drop of the 38 LEDs connected in series is $38 * 3\text{ V} = 114\text{ V}$. Accordingly, the forward voltage drop of the LEDs (114 V) connected in series equals the rectified voltage output of the driver (114 V).¹² Appx6304-6305 [POR, 4-5]. The Petitioner’s own expert agreed. Appx5092-5093 [Ex. 1107 (Baker Reply Decl.), ¶ 27] (“A person of ordinary skill in the art would have understood that this discussion in the ’400 patent explains that the bridge rectifier drops the voltage by 6V to provide a rectified AC voltage of 114V to 38 LEDs having a forward voltage drop of 114V.”).

Thus, the above passage does not redefine “matches.” On the contrary, it affirms the ordinary understanding of matches as “equivalence.” The construction of “matches” should be reversed on *de novo* review. No remand is required because it is clear from the intrinsic record that “matches” comports with its ordinary meaning and does not mean “less than.” *Qualcomm Inc. v. Intel Corp.*, 6 F.4th 1256, 1266 (Fed. Cir. 2021) (cite omitted).

¹² Petitioner’s counsel agreed with this understanding at the oral hearing. Hearing Trans., 23:11-17 (Petitioner: “this example that the patent is describing where you have 120 volts, and a rectifier that has 3 volts ... so it’s a 6-volt total drop. And then it talks about using 38 LEDs that would be sufficient for that, for the LEDs to have 3 volts. So what that is 120 on one side. With the AC, you have 6 volts. The output of the rectifier is 114 volts. Well, that output of that rectified driver, as its described there, would match the 114- volt drop of the LEDs -- 38 times 3.5 is 114.”).

The Board cites the '400 Patent at 9:49-51 as supporting its construction. Appx0036 [FWD] (citing Appx0130 ['400 Patent, 9:49-51]). That passage states that “strings of LEDs [are] connected together and driven direct with a high frequency AC voltage equal to or less than the total series voltage drop of the ... strings of LEDs.” This passage does not redefine “matches.” It does not even refer to “matches.” Indeed, it confirms the understanding of “matches” from the passage at 16:64-17:7, which uses the term to refer to equivalence. The inventor’s decision to refrain from using the term “matches” in the passage at 9:49-51 when referring to a voltage “being equal to or **less than**” confirms that “matches” does not encompass “less than.”

Considered as a whole, the specification teaches that in the context of Claim 7, “matches” means that the value of the rectified voltage output of the driver is equivalent within a manufacturing tolerance to the total forward voltage of the LED array. This is consistent with the ordinary meaning of “matches.” The specification does not redefine “matches” (as the Board implies); rather, it affirms its ordinary meaning through repeated and consistent characterization. *GPNE*, 830 F.3d at 1370; *VirnetX, Inc. v. Cisco Sys., Inc.*, 767 F.3d 1308, 1318 (Fed. Cir. 2014); *Phillips*, 415 F.3d at 1315; *Irdeto Access, Inc. v. Echostar Satellite Corp.*, 383 F.3d 1295, 1300 (Fed. Cir. 2004).

V. INDEPENDENT CLAIM 7 AND DEPENDENT CLAIMS 8-13 ARE PATENTABLE WHEN THE PROPER CLAIM CONSTRUCTION IS APPLIED FOR LIMITATION 7(f)'s "FORWARD VOLTAGE OF THE LEDs OF THE LED CIRCUIT MATCHES THE RECTIFIED [] AC VOLTAGE OUTPUT OF THE DRIVER".

A. The Board's Determination Must Be Reversed Because It is Based on the Application of the Board's Erroneous Construction of "Matches"

The Board rejected the Patent Owner's argument regarding limitation 7(f) because it was "based on the [Patent Owner's] premise that 'matches' means an equivalence within a manufacturing tolerance." Appx0035 [FWD]. The Board went on to determine its claim construction that "matches" encompasses "less than" in addition to "equivalence." Appx0036 [FWD]. The Board then applied its erroneous claim construction to find that Martin teaches the delivery of an unrectified AC voltage output that is less than the total maximum forward voltage of the LEDs, and, accordingly, the combination of Martin with Nerone allegedly meets limitation 7(f). Appx0036 [FWD] ("Martin ... is teaching that the voltage drop across individual LEDs is less than a maximum voltage" ... "voltage drop of 147 V is much less than the peak voltage"), Appx0038 [FWD] ("Martin chooses the number of LEDs 'such that the maximum voltage across each individual LED [during the peak in the alternating current cycle] is low enough so as not to damage the LEDs.'").

The Board's finding of obviousness is premised on the erroneous construction of limitation 7(f) that encompasses the rectified AC voltage output being less than

the forward voltage of the LEDs. Accordingly, the finding of unpatentability should be reversed for Claim 7 (and dependent Claims 8-13).

B. The Undisputed Record Evidence Demonstrates Claim 7 Is Patentable When The Correct Claim Construction Is Applied Because Martin Teaches That The Voltage Output Is Less Than The Forward Voltage Of The LEDs

This Court should reverse without remand. Applying the correct construction, the record evidence demonstrates that Martin as applied to Nerone fails to meet limitation 7(f) for a driver providing a rectified AC voltage output that is equivalent to the forward voltage drop of the LEDs. The Patent Owner explained—and the Board, the Petitioner, and the Petitioner’s own expert all agreed—that Martin teaches selecting the number of LEDs so that the peak AC voltage output of the driver is **less than** the 4.5 V maximum forward voltage of the LEDs. Appx0031 [FWD] (“Martin discloses selecting the number of LEDs to be 38 LEDs so that the voltage drop across each LED is less than the ‘maximum forward voltage’ of 4.5 V at the voltage peak”); Appx6332-6334 [POR, 32-34]; Appx5291-5292 [Ex. 2001 (Ducharme Decl.), ¶ 92]; Appx6454-6455 [Sur-reply, 13-14]; Appx6063 [Pet., 20]; Appx6401-6402 [Reply, 14-15]; Appx0246-0247 [Ex. 1002 (Baker Decl.), ¶ 123]. See Appx1877 [Martin, ¶ [0022]].

The Board and Petitioner rely **only on applying Martin** to Nerone to allegedly meet the “matches” limitation. Appx0038 [FWD]; Appx6064 [Pet., 21]. The Board

and Petitioner refer to extraneous references outside of Ground 1 (Nerone and Martin) to establish the POSITA's common knowledge for purposes of motivation to combine and reasonable expectation of success, **not to fill gaps** in the Nerone/Martin combination for meeting the "matches" limitation. See, e.g., Appx0031 [FWD] (Allen and Bockle used for motivation to combine and expectation of success), Appx0034-0035 [FWD] ("Petitioner further contends that is it not using these [extraneous] references for ... combining any of Cross, Allen, Bockle, or Birrell with [the Ground 1 references of] Nerone or Martin."). "We disagree with the Patent Owner that Petitioner is using any of Cross, Allen, Bockle, or Burrell for gap filling. As just discussed, these references are used to corroborate Dr Baker's testimony concerning the knowledge of a person of ordinary skill in the art." Appx0038 [FWD]. Accordingly, the extraneous references are not used to meet the claim limitation and cannot form an alternative basis for affirmance or remand.

Accordingly, Claim 7 is patentable because the combination of Martin and Nerone does not teach or suggest matching the AC voltage output to the forward voltage of the LEDs pursuant to limitation 7(f).

C. Besides Its Erroneous Construction of “Matches,” The Board Applied An Incorrect Construction of Limitation 7(f) That Reads Out The Requirement That A “Rectified AC Voltage Output” Matches the Forward Voltage of the LEDs

Limitation 7(f) provides that the forward voltage of the LEDs matches “the *rectified* [] **AC voltage output**” of the driver. It refers back to limitation 7(e) providing for “a driver connected to the bridge rectifier and configured to provide a *rectified output AC voltage* to the LED circuit array.” Appx0139 [’400 Patent, 27:54-56]. The Board acknowledged the Patent Owner’s point that Martin teaches selecting the number of LEDs based on an **unrectified** AC voltage output,¹³ not a **rectified** voltage output as required by limitation 7(f). See Appx0032 [FWD] (“Patent Owner next contends that Martin does not meet the recited voltage matching because it ‘selects the number of LEDs based on an **unrectified AC voltage** ..., not based on a **rectified** AC voltage’ as recited in limitation 7(f)”) (citing Appx6335 [POR, 35]) (emph. added).

The Board went on to hold that Martin’s teaching of an **unrectified** AC voltage output that is less than the forward voltage of the LEDs meets limitation 7(f). Appx0035-0038 [FWD]. In so doing, the Board erred by effectively construing limitation 7(f) as encompassing matching the forward voltage of LEDs to an unrectified AC voltage output. Put another way, the Board improperly reads

¹³ An unrectified AC voltage output is a pure AC voltage. AC mains is an example of an unrectified AC voltage. Appx0164 [Baker Decl., ¶ 25].

“rectified” out of the limitation. This is an error of claim construction to be reviewed *de novo*. *Qualcomm Inc. v. Intel Corp.*, 6 F.4th 1256, 1266 (Fed. Cir. 2021); *Ventana Medical Sys., Inc. v. Biogenex Laboratories, Inc.*, 473 F.3d 1173, 1181 (Fed. Cir. 2006) (reversing the district court’s claim construction because it improperly applied an implicit construction of “direct dispensing” to the claim term “dispensing”); *Carrum Technologies, LLC v. Unified Patents, LLC*, 2021 WL 3574209 at *6 (Fed. Cir. Aug. 13, 2021) (Board’s implicit interpretation of “a vehicle position in the turn” was erroneous).

The claim construction exercise begins with the claim language. *Phillips*, 415 F.2d at 1314; *Vitronics*, 90 F.3d at 1582. The claim expressly states that the matching is performed in reference to a “rectified [] AC voltage output.” Appx0139 [’400 Patent, 27:57-59]. Additionally, the specification supports the plain meaning of the claim language in disclosing that a **rectified** AC voltage output of 114 V matches the forward voltage of 114 V for the LEDs. Appx0133-0134 [’400 Patent, 16:64-17:7]. See Section IV.C, *supra* (noting the Petitioner and Petitioner’s expert agree). See Appx5092-5095 [Ex. 1107 (Baker Reply Decl.), ¶ 27] (“A person of ordinary skill in the art would have understood that this discussion in the ’400 patent explains that the bridge rectifier drops the voltage by 6V to provide a **rectified** AC voltage of 114V to 38 LEDs having a forward voltage drop of 114V.”) (emph. added).

The Board’s as-applied claim construction—that limitation 7(f) encompasses matching to an unrectified AC voltage output—is erroneous. This Court should reverse the finding of unpatentability without remand because the record is clear that Martin only discloses determining the forward voltage of the LEDs based on the peak voltage of an unrectified AC voltage, not based on a rectified AC voltage. As relied upon by the Board and the Petitioner, Martin discloses selecting the forward voltage of the LEDs based on the unrectified AC voltage output of the driver. Appx0038 [FWD] (citing Martin, ¶ [0022]). See Appx1877 [Martin ¶ [0022]] (“The number of LEDs is chosen such that the maximum voltage across each individual LED during the peak in the **alternating current cycle**¹⁴ is low enough so as not to damage the LEDs.”). Accordingly, Martin does not teach or suggest selecting the number of LEDs to provide a forward voltage matching a rectified AC voltage output to meet limitation 7(f).

Thus, Martin as applied to Nerone does not meet limitation 7(f). To add further context, there is a significant, patentably distinct difference between matching the forward voltage of the LEDs to an unrectified AC voltage output compared to matching the forward voltage of the LEDs to a rectified AC voltage output. Martin discloses selecting the number of LEDs so that at the peak value V_p of the unrectified

¹⁴ Martin discloses that the AC voltage could be 120 Vrms, 60 Vrms, 240 Vrms, etc. *Id.* These are unrectified AC voltage signals, such as the AC mains provided by an electrical outlet in a home.

voltage output of the AC signal, the voltage drop across each LED is just under the “maximum forward voltage” of 4.5 V, as illustrated below:

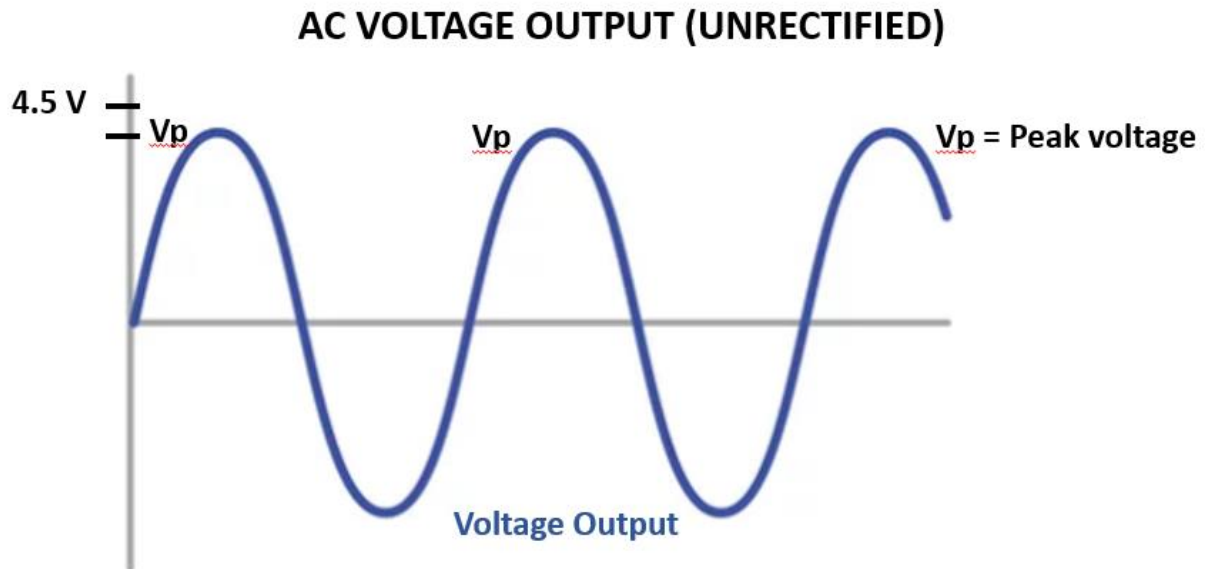

See Appx0175-0176 [Ex. 1002 (Baker Decl.), ¶ 39]
(unrectified AC voltage on left of Fig. 3.21 from Appx2137 [Ex. 1030
(MASTERING ELECTRONICS by Watson), 39]).

See Appx1877 [Martin, ¶ [0022]]. This achieves Martin’s goal of preventing “damage [to] the LEDs.” *Id.*

On the other hand, limitation 7(f) of the claim recites that the **rectified** AC voltage output (**red below**) is matched to the forward voltage of the series-connected LEDs, V_f :

AC VOLTAGE OUTPUT (RECTIFIED)

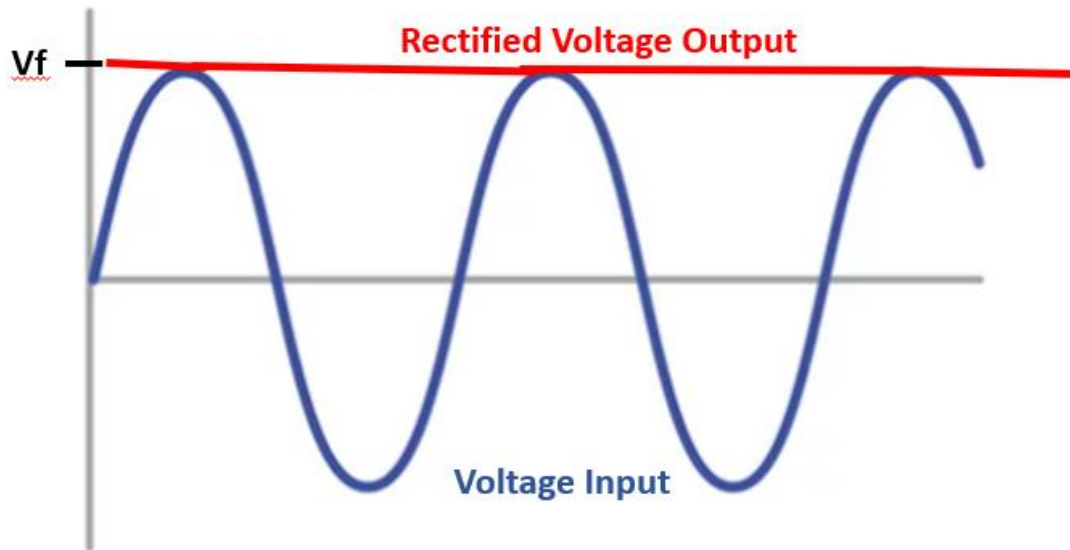

Vf = Forward voltage of LEDs

See Appx0175-0176 [Ex. 1002 (Baker Decl.), ¶ 39] (rectified AC voltage on right of Fig. 3.21 from Appx2137 [Ex. 1030 (*Mastering Electronics* by Watson), 39]).

As illustrated in the above figure, the claimed matching provides that the rectified AC voltage output is matched to the forward voltage V_f of the LEDs¹⁵ so that the series-connected LEDs are continuously driven by a voltage output that delivers light. In contrast, Martin is providing an unrectified AC voltage output that varies between negative and positive values such that it is not continuously driving the LEDs to produce light. In fact, in Martin more than half of the time (e.g., when

¹⁵ The Petitioner's own expert confirmed that LEDs have a forward voltage V_f at which the LEDs "turn on" and emit light. Appx0177-0178 [Ex. 1002 (Baker Decl.), ¶¶ 41-43] (light is emitted by an LED when a forward voltage V_f in the range of 2-3 V is applied); Appx1877 [Martin, ¶ [0022]] (forward voltage V_f is 3.5 V).

the AC voltage is negative) the LEDs are not emitting light at all. There is a profound distinction between Martin’s teaching and the feature of limitation 7(f).

For the aforementioned reasons, the Court should reverse the Board’s determination regarding Claim 7 without remand and find that Claim 7 (and dependent Claims 8-13) are patentable.

D. The Board’s Determination That the Petitioner Can Meet the “Matches” Limitation Without Determining Any Numerical Value is an Error of Law

The Patent Owner repeatedly objected that the Petition and the Petitioner’s expert’s declaration were devoid of any analysis showing that the **value** of the rectified output voltage of Nerone (at inductor 430 in Figure 4 of Nerone) would match the **value** of the forward voltage across Nerone’s four groups 410 of LEDs in the proposed Nerone/Martin combination. Appx6331-6332 [POR, 31-32]; Appx6455 [Sur-Reply, 14].

The Board determined that the Petitioner did not have to make any numerical showing that Nerone/Martin combination meets the requirement that the value of the rectified AC voltage output of the driver “matches” the value of the forward voltage of the LEDs. Appx0037 [FWD]. This is a matter of claim construction reviewed *de novo*. *Qualcomm*, 6 F.4th at 1266.

A POSITA would readily understand that “a forward voltage of the LEDs of the LED circuit array matches the rectified [] AC voltage output of the driver” is only

satisfied by showing the **value** of the forward voltage of the LED circuit array matches the **value** of the AC voltage output of the driver. It can hardly be disputed that “matches” refers to the matching of values. The specification discloses matching as occurring when the 114 V rectified voltage output of a driver (i.e., a value) equals the 114 V forward voltage of the LEDs (i.e., a value). See Section IV.C; Appx0133-0134 [’400 Patent, 16:64-17:7]. Even the Board’s incorrect claim construction of “matches” is articulated in terms of the rectified AC voltage output having a value that is “less than” the value of the forward voltage of the LEDs. Appx0036 [FWD].

The Petitioner feigns outrage that “PO demands some *specific number* of LEDs and output voltage for the modified Nerone system.” Appx6400 [Reply, 13] (orig. italics). But that is precisely what the ’400 Patent discloses in connection with this limitation: A specific number of LEDs (38) provides a forward voltage (114 V) that matches the value for the rectified output voltage (114 V). See Section IV.C; Appx0133-0134 [’400 Patent, 16:64-17:7].

Therefore, the intrinsic evidence demonstrates that limitation 7(f) requires a matching of values. The Court should reverse on the basis of this erroneous claim construction.

Further, the record evidence would not support a finding that the Nerone/Martin combination meets the requirement in limitation 7(f) that the values in the Nerone/Martin combination match. The Board reasons that a POSITA designing a

circuit would take care that the circuit driver delivers enough voltage so as not to underdrive the LEDs, while not delivering too much voltage so as to overdrive the LEDs. Appx0036 [FWD] (citing Appx0243-0244 [Ex. 1002 (Baker Decl.) ¶ 120]). The Board reasons that a POSITA mindful of such “not too little, not too much” considerations would “have used these factors to apply the teachings of Martin to configure Nerone’s circuitry” so that the rectified voltage output of Nerone’s driver would “match” the forward voltage of the LEDs. Appx0037 [FWD]; see Appx6059 [Pet., 16] (depicting annotated Fig. 4 of Nerone with driver voltage output at inductor 430 provided to LED groups 410). That is quite a jump, too much of a jump, going from “not too little, not too much” to holding that a POSITA would precisely select the circuit components so that the **value** of the rectified voltage output would match the **value** of the forward voltage of the LEDs in the modified Nerone system.¹⁶ The Board and Petitioner are obliged to provide more than a hand-waving exercise to render Claim 7 of the ’400 Patent unpatentable.

The Board’s reasoning that a POSITA allegedly “would have been capable” of determining the number of LEDs in Nerone’s LED groups (Appx0037 [FWD]) goes to reasonable expectation of success; it does not establish that the Nerone/Martin

¹⁶ The Board cites the Petitioner’s expert, who provides no analysis showing that the value of the forward voltage drop of Nerone’s LEDs in the modified Nerone/Martin system would match the value of the rectified voltage output of Nerone. Appx6080-6082 [Pet., 37-38] (citing Appx0247-0248 [Ex. 1002 (Baker Decl.), ¶ 124]; Appx5096 [Ex. 1107 (Baker Reply Decl.), ¶ 29]).

combination meets the requirement of limitation 7(f) that the value of the forward voltage drop of the LEDs matches the value of the rectified AC voltage output. The Board's follow-on assertion that it was "not necessary to provide" the details for the "proposed modification of Nerone" is unsustainable. *Id.* The Board fails to provide articulated reasoning tied to underlying evidence demonstrating that the proposed Nerone/Martin combination meets limitation 7(f). *In re Stepan Company*, 868 F.3d 1342, 1346 (Fed. Cir. 2017) (The Board must provide articulated reasoning with rational underpinnings that explains its conclusions as to how the prior art would be modified to correspond to the claimed invention.).

The Board's analysis on limitation 7(f) was carried out without getting down to the business of engaging the details of the proposed combination, such as by showing that the values of the voltages would match in the modified Nerone system. This nonspecific, results-oriented analysis was an exercise in impermissible hindsight reconstruction. *TQ Delta, LLC v. CISCO Systems, Inc.*, 942 F.3d 1352, 1357 (Fed. Cir. 2019); *see Kinetic Concepts, Inc. v. Smith & Nephew, Inc.*, 688 F.3d 1342, 1368 (Fed. Cir. 2012) ("We must be careful not to allow hindsight reconstruction of references to reach the claimed invention without any explanation as to how or why the references would be combined to produce the claimed invention.").

For the aforementioned reasons, the Court should reverse the Board's determination regarding Claim 7, and hold that Claim 7 and dependent Claims 8-13 are not unpatentable, without remand.

VI. THE BOARD'S DECISION MUST BE REVERSED AS TO CLAIMS 7-13 AND 17 BECAUSE THE MARTIN REFERENCE OF GROUNDS 1-6 IS NOT "PRINTED PUBLICATION" PRIOR ART WITHIN THE MEANING OF 35 U.S.C. § 311(b)

The Board held claims 7-13 and 17 unpatentable relying on Martin, U.S. Pat. Pub. No. 2004/0206970, in combination with other references. Appx0007, Appx0068 [FWD] (Grounds 1-6). But a patent can be challenged in an IPR "only on the basis of prior art consisting of *patents* or *printed publications*," 35 U.S.C. § 311(b) (emph. added)—which limits available prior art, as a matter of law, to only references that are themselves "a *prior art* patent or *prior art* printed publication." *Qualcomm Inc. v. Apple Inc.*, 24 F.4th 1367, 1375 (Fed. Cir. 2022) (emph. added). Martin is neither. It is undisputed that Martin is not a "patent"; it is a patent *application* that was abandoned and never issued as a patent. And Martin is not a "prior art printed publication," because it was not publicly accessible until it was published on October 21, 2004—well *after* the '400 Patent's February 25, 2004, priority date. Appx1867 [Martin, 1, (item (43))]. See Appx6049 [Pet. 6] ("the critical date for the '400 Patent is February 24, 2004."). Martin thus cannot serve under § 311(b) as a basis of the Petitioner's IPR. The holdings of unpatentability based on Martin must be reversed.

A. Martin Is Not a Prior Art “Printed Publication” Because It Was Not Publicly Accessible Until After the ’400 Patent’s Priority Date

This Court has repeatedly held that “[t]he statutory phrase ‘printed publication’ . . . mean[s] that before the critical date [of the challenged patent] the reference must have been *sufficiently accessible to the public* interested in the art.’” *In re Cronyn*, 890 F.2d 1158, 1160 (Fed. Cir. 1989) (emph. added); *accord, e.g., Acceleration Bay, LLC v. Activision Blizzard Inc.*, 908 F.3d 765, 772-74 (Fed. Cir. 2018) (affirming finding in IPR that reference was not “printed publication” because it “was not publicly accessible before the critical date”); *In re Lister*, 583 F.3d 1307, 1314, 1311-17 (Fed. Cir. 2009) (manuscript was not “printed publication” because it was not “publicly accessible” before critical date); *In re Klopfenstein*, 380 F.3d 1345, 1350 (Fed. Cir. 2004) (“[T]hroughout our case law, public accessibility has been the criterion by which a prior art reference will be judged for the purposes of [the] . . . ‘printed publication’ inquiry.”); *B/E Aerospace, Inc. v. C & D Zodiac, Inc.*, 709 F. App’x 687, 697-98 (Fed. Cir. 2017) (affirming finding in IPR that document was not “prior art printed publication” because petitioner “did not establish public accessibility . . . before the priority date”).

As this precedent makes clear, “‘public accessibility’” is “the touchstone in determining whether a reference constitutes a ‘printed publication.’” *Acceleration Bay*, 908 F.3d at 772 (additional quotation marks omitted). An IPR “petitioner . . . ha[s] the burden to prove [a reference] is a printed publication.” *Id.* To do so, the

petitioner must show that the reference was, before the critical date, “made available to the extent that persons interested and ordinarily skilled in the subject matter or art, exercising reasonable diligence, can locate it.” *Id.*

Martin was not publicly accessible before February 24, 2004, critical date of the '400 Patent. It was published by the PTO eight months later, on October 21, 2004. Appx1867 [Martin, 1]. Before that, Martin was confidential and not accessible by the public—indeed, it was legally required to “be kept in confidence” by the PTO. 35 U.S.C. § 122(a)-(b) (patent applications “shall be kept in confidence by the Patent and Trademark Office” until publication 18 months after filing); *see Cordis Corp. v. Boston Sci. Corp.*, 561 F.3d 1319, 1333-34 (Fed. Cir. 2009) (document shared with others was not yet “printed publication” because it was circulated under expectation of confidentiality based on “professional norms”). Here, the Petitioner never attempted to prove—and the Board never purported to find—otherwise. Because Martin was not publicly accessible before the '400 Patent's critical date, it is not a “prior art printed publication” and could not serve as a basis for challenging the patent in this IPR. § 311(b). *Qualcomm*, 24 F.4th at 1375; *see Acceleration Bay*, 908 F.3d at 772.

B. The Board Misconstrued the Statute

Despite Martin's undisputed lack of public accessibility before the critical date, the Board found it was a permissible basis for this IPR because, under pre-AIA

§ 102(e)(1), an “application for patent” may serve as prior art as of its filing date. Appx0010-0012 [FWD]. But whether Martin could be prior art as an “application for patent” under pre-AIA § 102(e)(1) is irrelevant under AIA § 311(b). Pre-AIA § 102 identifies various categories of prior art, including (1) “patent[s],” (2) “printed publication[s],” (3) inventions “in public use or on sale,” (4) inventions “known or used by others,” and (5) “application[s] for patent.” 35 U.S.C. § 102. But it is well-established that many of those prior art categories are unavailable in IPR. AIA § 311(b) specifies that only two categories are permissible bases for challenging a patent in an IPR: “patents” and “printed publications.” § 311(b). The “other types of prior art identified in § 102”—including pre-publication patent applications covered by § 102(e)(1)—may be asserted in (for example) infringement litigation, but cannot be a basis for an IPR. *Qualcomm*, 24 F.4th at 1376.

As pre-AIA § 102 makes clear, “printed publication[s]” and “application[s] for patent” are distinct terms with distinct meanings. *See Res-Care, Inc. v. United States*, 735 F.3d 1384, 1389 (Fed. Cir. 2013) (“Congress’s ‘use of different terms . . . generally implies that different meanings were intended.’”). Accordingly, courts have long recognized that a “mere application for patent” is neither a “printed publication” nor a “patent.” *Brown v. Guild*, 90 U.S. 181, 224 (1874) (citing Act of July 4, 1836, ch. 357, § 7, 5 Stat. 117, 119-20); *see In re Wertheim*, 646 F.2d 527, 532 (CCPA 1981) (application “was not . . . a patent or printed publication”);

Interurban Ry. & Terminal Co. v. Westinghouse Elec. & Mfg. Co., 186 F. ___ 166, 168 (6th Cir. 1911) (“[a]bandoned applications for patents” cannot “be classed among printed publications” because they are not “published by the Patent Office”); *Lyman Ventilating & Refrigerator Co. v. Lalor*, 15 F. Cas. 1163, 1164 (C.C.S.D.N.Y. 1874) (Blatchford, J.) (rejected patent application “has not the same effect of a printed publication” because it is not “made accessible to the public generally”). That remains true today: post-AIA § 102 continues to differentiate between “printed publication[s]” and “application[s] for patent.” § 102(a)(1)-(2).

When Congress limited IPRs to “only prior art consisting of patents or printed publications,” it excluded other categories of prior art from the permissible bases for an IPR. § 311(b). Pre-publication “application[s] for patent” are among those excluded categories. § 102(e)(1). The Board erred by ignoring § 311(b)’s strictures and by conflating distinct categories of prior art.

Rather than grapple with § 311(b)’s plain language, the Board focused on the AIA’s now-obsolete covered business method patent provision, which limited CBM challenges to “‘prior art that is described by [pre-AIA] section 102(a).’” Appx0011 [FWD] (quoting Pub. L. No. 112-29, § 18(a)(1)(C)(i), 125 Stat. 284, 330 (2011)). The Board reasoned that, “unlike CBMs, IPRs are not limited to prior art challenges solely under § 102(a),” and so (the Board concluded) IPRs necessarily may include challenges based on patent applications under § 102(e)(1). *Id.* That makes no sense.

The IPR statute does not use the same language as the CBM statute for a simple reason: Congress chose to limit IPRs to “prior art consisting of patents or *printed publications*,” §311(b) (emph. added), and the CBM statute’s language would not accomplish that. Pre-AIA § 102(a) is *not* limited to patents and printed publications; it also includes, *e.g.*, inventions “known or used by others in this country.” § 102(a). Nor are patents and printed publications confined to pre-AIA § 102(a); they also appear in pre-AIA § 102(b). The Board erred in “invent[ing] an atextual explanation for Congress’s drafting choices when the statute’s own terms supply an answer.” *SAS Inst., Inc. v. Iancu*, 138 S. Ct. 1348, 1357 (2018).

The Board refused to follow the many cases holding that “printed publication” prior art must be publicly accessible before the challenged patent’s critical date. For example, it dismissed the Patent Owner’s citation of *Samsung Electronics Co. v. Infobridge Pte. Ltd.*, 929 F.3d 1363 (Fed. Cir. 2019), because “that case deals with public accessibility under § 102(b).” Appx0011 [FWD]. But that is precisely the point: To determine “what constitutes a ‘printed publication’” that can be asserted in an IPR, *Infobridge* looked to the meaning of the “printed publication” statutory language in pre-AIA § 102(b), and held that the “statutory text . . . impos[es] two requirements: (1) that a putative prior art reference be printed and (2) that the reference be published, *i.e.*, *accessible to the public*.” 929 F.3d at 1368-69 (emph. added). The reason *Infobridge* “deals with public accessibility” (Appx0011 [FWD])

is because public accessibility is a requirement for a prior art “printed publication.” And because Martin *lacked* public accessibility as of the critical date of the ’400 Patent, it is not a prior art printed publication.

Insofar as the Board believed that “printed publication” means something different in § 102 than in § 311(b), nothing supports that view. This Court has repeatedly given “printed publication” the same meaning in IPRs governed by § 311(b) as it has in other cases. *See, e.g., Infobridge*, 929 F.3d at 1368 (citing *In re Wyer*, 655 F.2d 221, 225 (CCPA 1981)); *Jazz Pharms., Inc. v. Amneal Pharms., LLC*, 895 F.3d 1347, 1355 (Fed. Cir. 2018) (citing *In re Hall*, 781 F.2d 897, 898-99 (Fed. Cir. 1986)); *Acceleration Bay*, 908 F.3d at 772-74 (citing *Voter Verified, Inc. v. Premier Election Sols., Inc.*, 698 F.3d 1374, 1380 (Fed. Cir. 2012)); *Klopfenstein*, 380 F.3d at 1350; *Cronyn*, 890 F.2d at 1161. Properly so: The “normal presumption” is that “when Congress uses a term in multiple places within a single statute, the term bears consistent meaning throughout.” *Azar v. Allina Health Servs.*, 139 S. Ct. 1804, 1812 (2019). Under post-AIA § 102, like pre-AIA § 102, “printed publications” must be “publicly accessible.” *Valve Corp. v. Ironburg Inventions Ltd.*, 8 F.4th 1364, 1370 n.3, 1373 (Fed. Cir. 2021). The term is properly given the same meaning when it appears elsewhere in the statute, including § 311(b).

Congress, moreover, is “presumed to be aware of judicial decisions interpreting statutory language.” *Qualcomm*, 24 F.4th at 1375. When Congress uses a phrase

with a settled judicial interpretation—like “printed publication”—it presumptively “adopt[s] the earlier judicial construction of th[e] phrase.” *Helsinn Healthcare S.A. v. Teva Pharms. USA, Inc.*, 139 S. Ct. 628, 633-34 (2019); see *Taggart v. Lorenzen*, 139 S. Ct. 1795, 1801 (2019) (“When a statutory term is obviously transplanted from another legal source, it brings the old soil with it.” (internal quotation marks omitted)). At the time of the AIA’s enactment—and long before—“public accessibility” was understood to be “the ‘touchstone in determining whether a reference constitutes a ‘printed publication.’” *ResQNet.com, Inc. v. Lansa, Inc.*, 594 F.3d 860, 866 (Fed. Cir. 2010); see also *Orion IP, LLC v. Hyundai Motor Am.*, 605 F.3d 967, 974 (Fed. Cir. 2010); *Lister*, 583 F.3d at 1311; *Klopfenstein*, 380 F.3d at 1349. And “printed publication[s]” had been understood for over a century to exclude “application[s] for patent.” *Brown*, 90 U.S. at 224. When Congress used the term “printed publication” in §311(b), it adopted that longstanding judicial construction.

While ignoring the many precedential decisions holding that “printed publications” must be publicly accessible before the critical date of the patent, the Board cited a non-precedential decision, *Purdue Pharma L.P. v. Iancu*, 767 F. App’x 918 (Fed. Cir. 2019). Appx0011-0012 [FWD]. But *Purdue* never addressed whether patent applications not published before the critical date are prior art “printed publications” under §311(b). The patent owner did not raise that issue. The term

“printed publication” appears nowhere in the opinion. The patent owner’s argument that a given patent application was not prior art was “based entirely on its contention that the [challenged] claims . . . ha[d] written description support in [a] provisional” and thus were entitled to the provisional’s earlier priority date. *Purdue*, 767 F. Appx at 925. *Purdue* simply does not bear on the question at hand.

In cases not cited by the PTAB, this Court has treated *patents* as having the effective date of their application pursuant to § 102(e)(2) in an IPR. *See, e.g., Becton, Dickinson & Co. v. Baxter Corp. Englewood*, 998 F.3d 1337, 1344-45 (Fed. Cir. 2021); *Merck Sharp & Dohme Corp. v. Microspherix LLC*, 814 F. App’x. 575, 578-80 (Fed. Cir. 2020). But that question was not disputed in those cases. And it is a different question. An earlier-filed, later-published “application for patent” like the Martin reference in this IPR is not one of the specified categories of prior art that may be asserted. § 102(e)(1); § 311(b).

The Board’s decision cannot be sustained simply because Martin may be a *type* of prior art (“application for patent”) that is later published. Prior art serving as the basis of an IPR must be “a prior art patent or prior art printed publication.” *Qualcomm*, 24 F.4th at 1375. As this Court has emphasized, IPRs may be based only on “patents or printed publications’ *existing at the time of the patent application.*” *Id.* at 1374 (cite omitted) (orig. emph.). Martin is not a prior art printed publication

as to the '400 Patent because it was not publicly available before the patent's critical date.¹⁷

The plain statutory language of § 311(b) restricts IPRs to challenges based on “patents or printed publications,” excluding earlier-filed, later-published patent applications. Martin is neither a patent nor a prior art printed publication. Accordingly, the unpatentability findings as to Claims 7-13 and 17 (Grounds 1-6) should be reversed.

¹⁷ As *Qualcomm* explained, applicant-admitted prior art may be considered in an IPR “to some extent” as evidence “for establishing the background knowledge possessed by a person of ordinary skill in the art.” *Id.* at 1376. But since it is not a “prior art patent or prior art publication,” it cannot be used as a “basis” for the IPR. *Id.* It is undisputed here that Martin is a stated reference in Grounds 1-6, and thus forms a basis for the IPR. See Appx6047-6048 [Pet., 4-5].

CONCLUSION

For the reasons set forth above, the Board's decision and judgment should be reversed.

Respectfully submitted,

/s/ Stephen T. Schreiner

Stephen T. Schreiner

James T. Carmichael

Stephen P. McBride

Minghui Yang

CARMICHAEL IP, PLLC

8607 Westwood Center Drive, Suite 270

Tysons, VA 22182

(703) 646-9255

schreiner@carmichaelip.com

jim@carmichaelip.com

stevemcbride@carmichaelip.com

mitch@carmichaelip.com

Counsel for Appellant Lynk Labs, Inc.

Date: January 10, 2024

CERTIFICATE OF FILING AND SERVICE

I hereby certify that on this 10th day of January, I caused this Brief of Appellant to be filed electronically with the Clerk of the Court using the CM/ECF System, which will send notice of such filing to the following registered CM/ECF users:

Naveen Modi
Mark Consilvio
Joseph Palys
PAUL HASTINGS, LLP
2050 M Street, NW
Washington, DC 20036
(202) 551-1700
naveenmodi@paulhastings.com
markconsilvio@paulhastings.com
josephpalys@paulhastings.com

/s/ Stephen T. Schreiner _____
Stephen T. Schreiner
Counsel for Appellant Lynk Labs, Inc.

January 10, 2024

CERTIFICATE OF COMPLIANCE

1. This brief complies with type-volume limits because, excluding the parts of the document exempted by Fed. R. App. R. 32(f) (cover page, disclosure statement, table of contents, table of citations, statement regarding oral argument, signature block, certificates of counsel, addendum, attachments):

[X] this brief contains 13,581 words.

2. This brief complies with the typeface and type style requirements because:

[X] this brief has been prepared in a proportionally spaced typeface using *Microsoft Word 365* in 14pt Times New Roman

Respectfully submitted,

/s/ Stephen T. Schreiner
Stephen T. Schreiner
Counsel for Appellant Lynk Labs, Inc.

January 10, 2024

ADDENDUM

Paper 33. Final Written Decision (June 26 2023)Appx0001

Ex. 1001 US Patent No. 10,687,400, Miskin et al.
(June 16 2020).....Appx0075

Trials@uspto.gov
571-272-7822

Paper 33
Date: June 26, 2023

UNITED STATES PATENT AND TRADEMARK OFFICE

BEFORE THE PATENT TRIAL AND APPEAL BOARD

SAMSUNG ELECTRONICS CO., LTD.,
Petitioner,

v.

LYNK LABS, INC.,
Patent Owner.

IPR2022-00149
Patent 10,687,400 B2

Before JON B. TORNQUIST, ARTHUR M. PESLAK, and
STEPHEN E. BELISLE, *Administrative Patent Judges*.

PESLAK, *Administrative Patent Judge*.

JUDGMENT
Final Written Decision
Determining All Challenged Claims Unpatentable
35 U.S.C. § 314(a)

IPR2022-00149
Patent 10,687,400 B2

I. INTRODUCTION

Petitioner, Samsung Electronics Co., Ltd., filed a Petition (Paper 1, “Pet.”) requesting an *inter partes* review of claims 7–20 of U.S. Patent No. 10,687,400 B2 (Ex. 1001, “the ’400 patent”). In support of the Petition, Petitioner submitted a Declaration of R. Jacob Baker, Ph.D., P.E. Ex. 1002. Patent Owner, Lynk Labs, Inc., filed a Preliminary Response. Paper 12. We instituted this *inter partes* review as to all challenged claims and all grounds presented in the Petition. Paper 16 (“Dec.”).

After institution, Patent Owner filed a statutory disclaimer of claims 14 and 18–20. Ex. 2011. Our review is, thus, limited to the remaining claims 7–13 and 15–17 (“the challenged claims”).

During the course of trial, Patent Owner filed a response to the Petition. Paper 20 (“PO Resp.”). Patent Owner filed a Declaration of Alfred D. Ducharme in support of the Patent Owner Response. Ex. 2001. Petitioner filed a Reply to the Patent Owner Response. Paper 24 (“Pet. Reply”). Petitioner filed a Reply Declaration of R. Jacob Baker, Ph.D., P.E. Ex. 1107. Patent Owner filed a Sur-Reply. Paper 27 (“Sur-reply”). An oral hearing was held on March 28, 2023 and a transcript has been entered into the record. Paper 32 (“Tr.”).

We have jurisdiction under 35 U.S.C. § 6. This is a Final Written Decision under 35 U.S.C. § 318(a) as to the patentability of the challenged claims of the ’400 patent. For the reasons discussed below, we determine Petitioner establishes by a preponderance of the evidence that all of the challenged claims are unpatentable.

IPR2022-00149
Patent 10,687,400 B2

A. Related Matters

The parties state that the '400 patent is asserted in *Samsung Electronics Co. v. Lynk Labs, Inc.*, Case No. 1:21-cv-02665 (N.D. Ill.). Pet. 1; Paper 4, 1. The parties also assert that various patents and patent applications may be affected by a decision in this case. Pet. 2–3; Paper 4, 1.

B. Real Parties-in-Interest

Petitioner identifies itself and Samsung Electronics America, Inc. as real parties-in-interest. Pet. 1. Patent Owner identifies itself as the only real party-in-interest. Paper 4, 1.

C. The '400 Patent (Ex. 1001)

The '400 patent is titled AC Light Emitting Diode and AC LED Drive Methods and Apparatus. Ex. 1001, code (54). The '400 patent issued on June 16, 2020 from an application filed on Nov. 22, 2019. *Id.* at codes (45), (22). The '400 patent is related to a series of applications, the earliest of which was filed on Feb. 25, 2005, which in turn relate to a series of provisional applications, the earliest of which was filed on Feb. 25, 2004. *Id.* at code (60).

The '400 patent is directed to “alternating current (‘AC’) driven LEDs, LED circuits and AC drive circuits and methods.” *Id.* at 1:60–62. The '400 patent explains that the disclosed “LED light emitting device and LED light system [are] capable of operating during both the positive and negative phase of an AC power supply.” *Id.* at 13:34–36. Embodiments of the '400 patent include a “series string of diodes and/or LEDs having a bridge rectifier connected [there]across.” *Id.* at 6:55–57. The '400 patent discloses that the “rectifier ... may be mounted on [an] insulating substrate

IPR2022-00149
 Patent 10,687,400 B2

... along with any LEDs” and a capacitor “included in the light emitting devices may like wise [sic] be mounted on [the] substrate.” *Id.* at 16:35–45.

Figure 22 of the '400 patent is reproduced below:

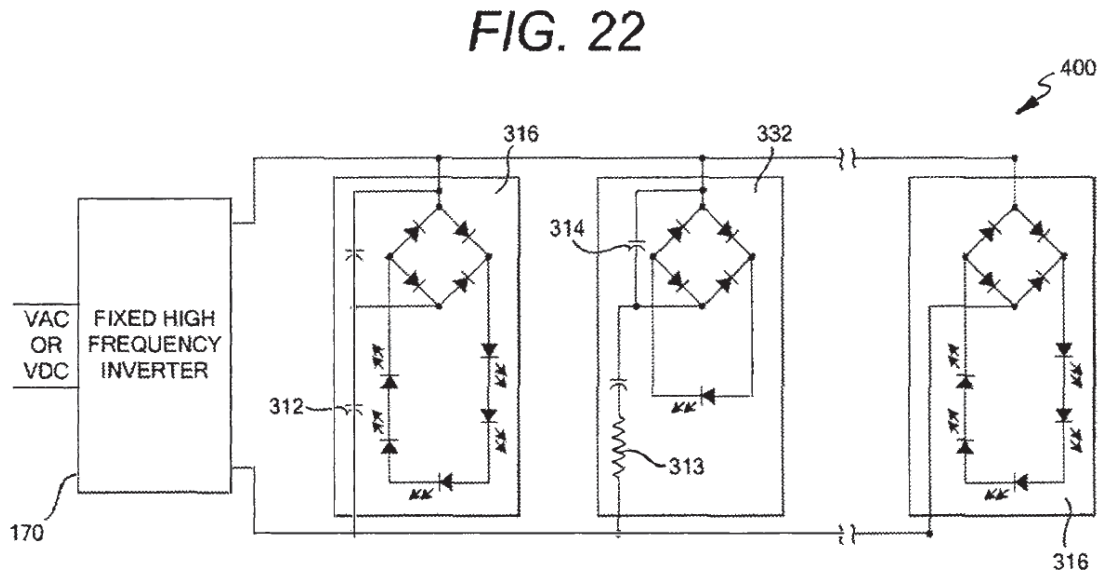

Figure 22 of the '400 patent “shows a schematic view of a preferred embodiment of” an AC lighting system. *Id.* at 11:54–55. System 400, shown in Figure 22, includes a plurality of devices 316, 332 each having at least one LED. *Id.* at 16:19:43, 17:50–51. System 400 is connected to a high frequency inverter AC drive and is driven by an AC drive method. *Id.* at 17:50–52. In particular, device 316 includes plural LEDs 306 connected in series and mounted on insulating substrate 318. *Id.* at 16:21–24, Fig. 18. Device 316 also includes a rectifier that drives the LEDs and that is also mounted on the substrate. *Id.* at 16:34–36. “Any capacitors 312, 314 or resistors 313 included in the light emitting devices may like wise [sic] be mounted on substrate 318.” *Id.* at 16:41–43.

IPR2022-00149
 Patent 10,687,400 B2

Figure 13 of the '400 patent is reproduced below:

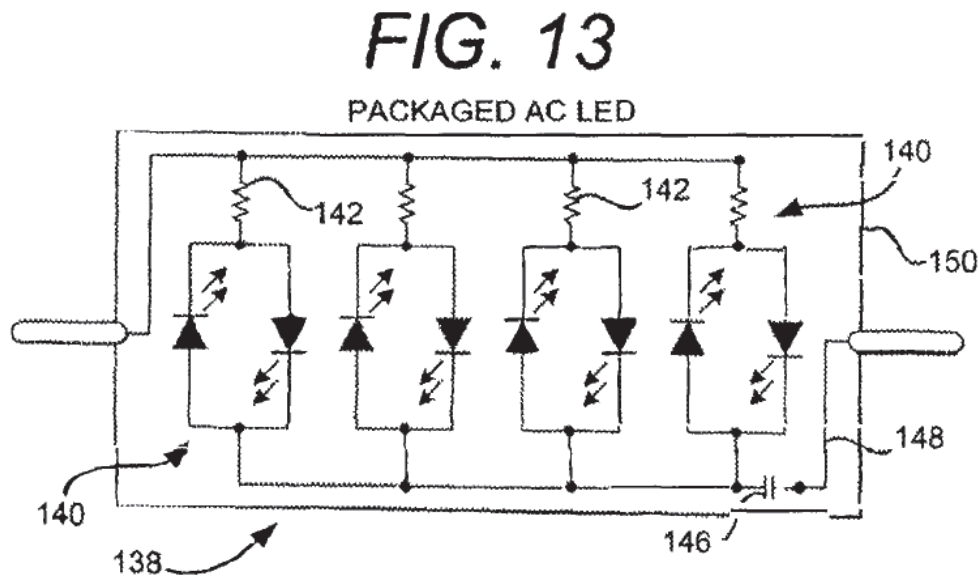

Figure 13 of the '400 patent “shows a schematic view of a preferred embodiment of” an AC light emitting device. *Id.* at 11:36–37.

In the device shown in Figure 13, individual sets of two opposing parallel light emitting devices 140 are integrated into package 150 and are driven by an AC drive method. *Id.* at 15:47–56. In certain embodiments, the package may include a reflective substrate. *Id.* at 6:1–2; 26:29–36. In addition, having integrated capacitors and resistors of equal or different values enables the devices to operate at different drive currents from a single source AC drive method. *Id.* at 17:55–59; *see also id.* at 14:29–32.

The '400 patent explains:

Regardless of whether rectifier 302 and LEDs 306 are integrated or mounted in a single package or are discretely packaged and connected, in order to drop higher voltages any number of LEDs may be connected in series or parallel in a device to match a desired voltage and light output. For example, in a lighting device that is run off of a 120 V source and contains LEDs having a forward operating voltage of 3V each connected to a bridge rectifier having diodes also having a forward operating voltage

IPR2022-00149
Patent 10,687,400 B2

of 3V each, approximately 38 LEDs may be placed in series to drop the required voltage.

Id. at 16:64–17:7.

D. Challenged Claims

Claim 7 is reproduced below with Petitioner’s labels [a]–[g] added for ease of reference:

7. [a] A lighting system comprising:
 - [b] an LED circuit array comprising an LED circuit comprising a plurality of LEDs connected in series;
 - [c] a capacitor;
 - [d] a bridge rectifier configured to receive an input AC voltage from a mains power source;
 - [e] a driver connected to the bridge rectifier and configured to provide a rectified output AC voltage to the LED circuit array;
 - [f] wherein a forward voltage of the LEDs of the LED circuit array matches the rectified input AC voltage output of the driver; and
 - [g] wherein the LED circuit array, the capacitor, the bridge rectifier, and the driver are all mounted on a single substrate.

IPR2022-00149
Patent 10,687,400 B2

E. Prior Art and Asserted Grounds

In light of Patent Owner’s disclaimer of claims 14 and 18–20 (Ex. 2011), we address the following grounds challenging claims 7–13 and 15–17:

Claim(s) Challenged	35 U.S.C.¹ §	Reference(s)/Basis
7, 9, 11	§ 103(a)	Nerone ² , Martin ³
8	§ 103(a)	Nerone, Martin, Morgan ⁴
10	§ 103(a)	Nerone, Martin, Zinkler ⁵
12	§ 103(a)	Nerone, Martin, Michael ⁶
13	§ 103(a)	Nerone, Martin, Michael, Gleener ⁷
7, 9–11, 17	§ 103(a)	Zhang ⁸ , Martin
8	§ 103(a)	Zhang, Martin, Morgan
15	§ 103(a)	Zhang, Mosebrook ⁹
16	§ 103(a)	Zhang, Michael, Gleener

¹ The Leahy-Smith America Invents Act, Pub. L. No. 112-29, 125 Stat. 284 (2011) (“AIA”), included revisions to 35 U.S.C. §§ 102 and 103 that became effective after the earliest claimed priority date of the challenged claims. Because neither party argues otherwise, we apply the pre-AIA version of 35 U.S.C. § 103.

² U.S. Patent No. 6,411,045 B1 issued June 25, 2002 (Ex. 1032) (“Nerone”).

³ U.S. Patent Application Publication No. 2004/0206970 A1 published Oct. 21, 2004 (Ex. 1015) (“Martin”).

⁴ U.S. Patent No. 7,202,613 B2 issued Apr. 10, 2007 (Ex. 1033) (“Morgan”).

⁵ U.S. Patent No. 6,300,725 B1 issued Oct. 9, 2001 (Ex. 1042) (“Zinkler”).

⁶ U.S. Patent No. 4,656,398 issued Apr. 7, 1987 (Ex. 1008) (“Michael”).

⁷ U.S. Patent Application Publication No. 2002/0175870 A1 published Nov. 28, 2002 (Ex. 1039) (“Gleener”).

⁸ U.S. Patent Application Publication No. 2002/0021573 A1 published Feb. 21, 2002 (Ex. 1012) (“Zhang”).

⁹ U.S. Patent No. 5,982,103 issued Nov. 9, 1999 (Ex. 1018) (“Mosebrook”).

IPR2022-00149
Patent 10,687,400 B2

II. ANALYSIS

A. Overview

Petitioner bears the burden of establishing the unpatentability of the challenged claims by a preponderance of the evidence. 35 U.S.C. § 316(e); 37 C.F.R. § 42.1(d). This burden of persuasion never shifts to Patent Owner. *Dynamic Drinkware, LLC v. Nat’l Graphics, Inc.*, 800 F.3d 1375, 1378 (Fed. Cir. 2015).

A claim is unpatentable under § 103(a) if the differences between the claimed subject matter and the prior art are such that the subject matter, as a whole, would have been obvious at the time the invention was made to a person having ordinary skill in the art to which said subject matter pertains. *KSR Int’l Co. v. Teleflex Inc.*, 550 U.S. 398, 406 (2007). The question of obviousness is resolved on the basis of underlying factual determinations, including (1) the scope and content of the prior art; (2) any differences between the claimed subject matter and the prior art; (3) the level of skill in the art; and (4) when in evidence, objective indicia of non-obviousness (i.e., secondary considerations)¹⁰. *Graham v. John Deere Co.*, 383 U.S. 1, 17–18 (1966).

B. Level of Ordinary Skill in the Art

Petitioner contends that a skilled artisan “would have had at least a bachelor’s degree in electrical engineering, computer engineering, computer science, physics, or the equivalent, and two or more years of experience with LED devices and/or related circuit design, or a related field.” Pet. 7 (citing

¹⁰ No evidence of secondary considerations has been presented by the parties.

IPR2022-00149
Patent 10,687,400 B2

Ex. 1002 ¶¶ 20–21). Petitioner further contends that “[m]ore education can supplement practical experience and vice versa.” *Id.*

Patent Owner contends that a person of ordinary skill in the art would have “had, at least a bachelor’s degree in electrical engineering, computer engineering, computer science, physics, or the equivalent, and two or more years of experience with LED devices and related LED circuit design. Lack of work experience could have been remedied by additional education and vice versa.” PO Resp. 7 (citing Ex. 2001 ¶¶ 38–42). Patent Owner contends this is a similar definition as “provided by Petitioner” but Petitioner’s definition is “overbroad in several respects, as explained by Dr. Ducharme,” including allowing an individual with no experience in LEDs or LED devices to be a person of ordinary skill in the art. *Id.* (citing Ex. 1002 ¶¶ 20–21; Ex. 2001 ¶¶ 40–41).

Petitioner contends that “[t]here is no meaningful dispute over a [person of ordinary skill in the art].” Pet. Reply 1.

We apply Patent Owner’s proposed level of ordinary skill in the art because it requires specific experience with LED circuit design, and, thus, more closely aligns with the level of skill reflected in the ’400 patent and the prior art of record. However, if we were to apply Petitioner’s proposed level of skill, our Decision would not be affected.

C. Claim Construction

We apply the same claim construction standard used by Article III federal courts and the ITC, both of which follow *Phillips v. AWH Corp.*, 415 F.3d 1303 (Fed. Cir. 2005) (en banc), and its progeny. 37 C.F.R. § 42.100(b) (2020). This claim construction standard includes construing claims in accordance with “the ordinary and customary meaning of such

IPR2022-00149
Patent 10,687,400 B2

claim as understood by one of ordinary skill in the art and the prosecution history pertaining to the patent.” *Id.*

Petitioner contends that “no special constructions are necessary.” Pet. 8; Pet. Reply 2. “Patent Owner has applied the plain and ordinary meaning of the claim terms.” PO Resp. 8.

Upon review of the record, we determine that no claim terms require express construction. *See Nidec Motor Corp. v. Zhongshan Broad Ocean Motor Co.*, 868 F.3d 1013, 1017 (Fed. Cir. 2017) (noting that “we need only construe terms ‘that are in controversy, and only to the extent necessary to resolve the controversy’”) (citing *Vivid Techs., Inc. v. Am. Sci. & Eng’g, Inc.*, 200 F.3d 795, 803 (Fed. Cir. 1999)).

D. Patent Owner’s Contention that Martin is not Available as Prior Art

Patent Owner contends that certain grounds “fail because . . . Martin is not available as prior art in an IPR.” PO Resp. 18. Patent Owner contends that “[t]he Petition presumes that Martin qualifies as prior art under § 102(e)(1)” but “Martin is neither a ‘patent’ nor a ‘printed publication’ as of the 400 Patent priority date of February 25, 2004.” *Id.* at 18–19. Patent Owner further contends that “Martin is not a ‘patent’ at least because it is an application that abandoned and never issued as a patent” and “is not prior art consisting of . . . printed publications under 35 U.S.C. § 311(b) because it was not published before the 400 Patent priority date.” *Id.* at 19. According to Patent Owner, “Martin first became public on its publication date of October 21, 2004 . . . which is after the February 25, 2004 priority date of the 400 Patent.” *Id.* (citing Pet. 6; Ex. 1002 ¶ 18; Ex. 1005, 1); *see also id.* (“The effective date of ‘printed publication’ prior art is the date it is ‘published, *i.e.*, accessible to the public.”) (citing *Samsung Elecs. Co. v.*

IPR2022-00149
Patent 10,687,400 B2

Infobridge Pte. Ltd., 929 F. 3d 1363, 1368, 1370 (Fed. Cir. 2019)). Patent Owner further contends that Petitioner cites no authority for its “attempt[] to invoke Martin’s April 16, 2003 filing date as its effective prior art date” under § 102(e). *Id.* at 20.

Petitioner counters that “Martin qualifies as a ‘patent[] and printed publication[] under § 311(b) *at least* because it is ‘an application for patent, published under section 122(b), by another *filed* in the United States before the invention by the applicant for patent’ according to § 102(e)(1).” Pet. Reply 32–33. Petitioner further contends that “[t]he well-established AIA-framework permits the use of §102(e) prior art in IPR proceedings.” *Id.* at 33 (citations omitted). Petitioner further contends that Patent Owner’s cited cases under § 102(a) are inapt. *Id.* (citing PO Resp. 33).

We agree with Petitioner.

The statute governing the formerly available CBM proceeding explicitly limits challenges based on “prior art that is described by section 102(a).” AIA § 18(a)(1)(C). In contrast, § 311(b) permits challenges “on the basis of prior art consisting of patents or printed publications.” The language in § 311(b) implies that, unlike CBMs, IPRs are not limited to prior art challenges solely under § 102(a). Patent Owner relies, *inter alia*, on *Infobridge*, but that case deals with public accessibility under § 102(b). *Infobridge*, 929 F. 3d at 1368–69.

The parties do not cite to any Federal Circuit decisions that squarely address this issue. However, the Federal Circuit applied § 102(e) patent application publication prior art in an appeal from an IPR. *See, e.g., Purdue Pharma L.P. v. Iancu*, 767 Fed. App’x 918, 920–21, 926 (Fed. Cir. 2019)

IPR2022-00149
Patent 10,687,400 B2

(nonprecedential) (determining that a § 102(e) patent application publication, “Joshi”, was available as prior art in an IPR).

The Board has also instituted trials and determined claims to be unpatentable based on patent application publications under § 102(e). *See, e.g., Patent Qual. Assurance, LLC v. VLSI Tech. LLC*, IPR2021-01229, Paper 129 at 27–29 (PTAB June 13, 2023) (determining challenged claims unpatentable based, in part, on patent application publication available as prior art under § 102(e)); *Idle Free Sys., Inc. v. Bergstrom, Inc.*, IPR2012-00027, Paper 14 at 27 (PTAB Jan. 31, 2013) (instituting trial on § 102(e) ground based on a patent application publication). Although not precedential, these decisions are persuasive.

For the foregoing reasons, we find Patent Owner’s argument that Martin is not available as prior art in this proceeding unavailing.

E. Ground 1: Obviousness over Nerone and Martin

Petitioner contends that claims 7, 9, and 11 are unpatentable over Nerone and Martin. Pet. 9–32. In support thereof, Petitioner identifies the disclosures in Nerone and Martin alleged to describe the subject matter in these claims. *Id.* Additionally, Petitioner cites to the declaration of Dr. Baker in support of the Petition. Ex. 1002 ¶¶ 104–144.

Patent Owner contends that the prior art does not teach certain limitations of claim 7. PO Resp. 21. In particular, Patent Owner contends that the combination does not disclose “an LED circuit array comprising an LED circuit comprising a plurality of LEDs connected in series” and “a forward voltage of the LEDs of the LED circuit array matches the rectified input AC voltage output of the driver.” *Id.*

IPR2022-00149
 Patent 10,687,400 B2

We begin our analysis with a brief overview of Nerone and Martin. We then address the parties' respective contentions with respect to claims 7, 9, and 11.

1. *Nerone – Ex. 1032*

Nerone is titled Light Emitting Diode Power Supply. Ex. 1032, code (54). Nerone discloses “a power supply circuit for operating a light source, particularly, an array of light emitting diodes (LEDs).” *Id.* at 1:5–9. Figure 4 of Nerone is reproduced below:

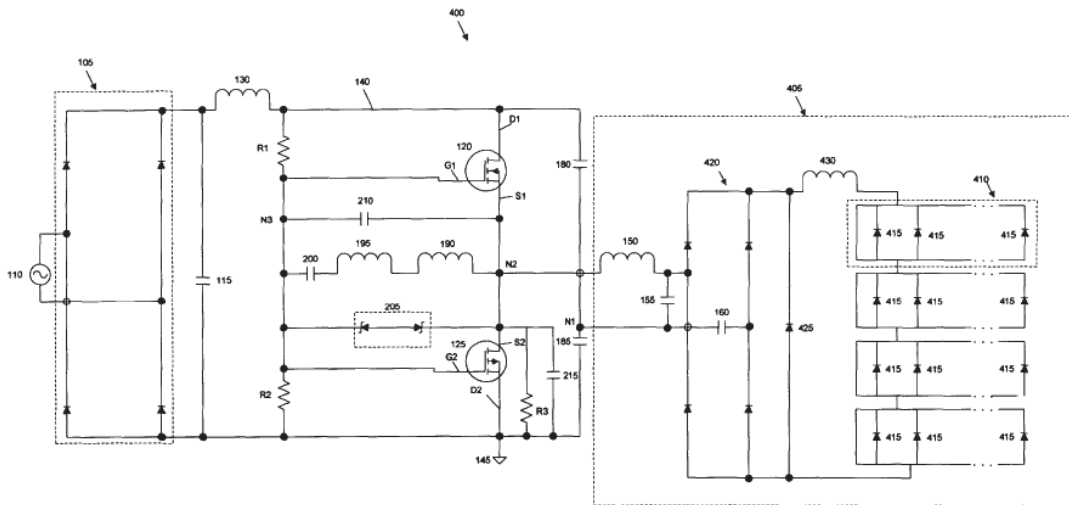

FIG. 4

Figure 4 is a schematic diagram of a power supply circuit 400 for an LED traffic signal. *Id.* at 2:56–57, 5:51–52.

Power supply circuit 400 includes resonant load circuit 405 having resonant inductor 150, resonant capacitor 155, and matching capacitor 160. Ex. 1032, 5:51–57. Resonant circuit 405 “further includes at least one group 410 of LEDs 415 connected in parallel and polarized in the same direction. The groups 410 of LEDs 415 are connected in series.” *Id.* at 5:57–60. Nerone explains that “[a] first rectification means or full-wave bridge

IPR2022-00149
 Patent 10,687,400 B2

rectifier 105 coupled to an AC source 110 converts an AC current to DC current. A smoothing capacitor 115, connected in parallel to the bridge rectifier 105 maintains an average voltage level.” *Id.* at 2:65–3:2.

Nerone discloses that “second bridge rectifier 420, which is coupled in parallel to the resonant capacitor 155, re-converts the AC current to DC current.” Ex. 1032, 5:65–67. Nerone explains that “diode 425 is connected in parallel to the second bridge rectifier 420” and “allows current to flow continuously through the current limiting inductance 430, which limits the current supplied to the LEDs.” *Id.* at 6:3–6.

2. *Martin – Ex. 1015*

Martin describes LEDs formed on a single substrate connected in series for use with an AC source. Ex. 1015, code (57). Figure 5 of Martin is reproduced below:

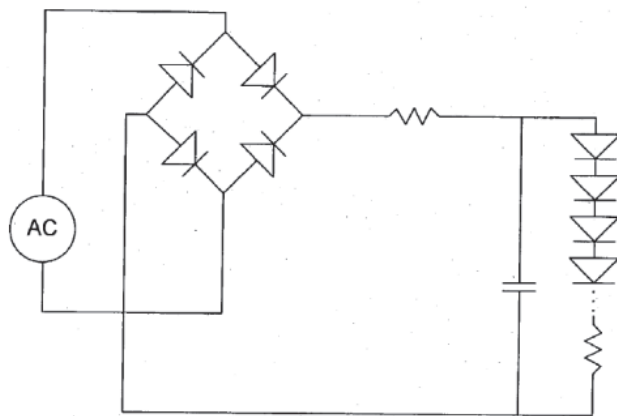

Fig. 5

Figure 5 depicts an LED array and full bridge rectifier for rectifying the AC source. *Id.* ¶ 24.

The full bridge rectifier of Figure 5 can be an external component or integrated into a submount. Ex. 1015 ¶ 24. A capacitor filters the rectified voltage to provide nearly direct current to an LED array. *Id.*

IPR2022-00149
Patent 10,687,400 B2

According to Martin, “[e]xcessive forward voltage can damage the LEDs irreversibly.” Ex. 1015 ¶ 21. Martin explains that “[s]eries interconnection reduces the voltage drop across each LED to a level that does not exceed the maximum forward voltage of each LED.” *Id.* In this manner, “[t]he number of LEDs in the monolithic array may be selected to achieve a particular voltage drop across each device . . . such that the maximum voltage across each individual LED during the peak in the alternating current cycle is low enough so as to not damage the LEDs.” *Id.* ¶ 22.

3. *Claim 7*

[a] A lighting system comprising:

Petitioner contends that, to the extent the preamble is limiting, Nerone discloses “a lighting system.” Pet. 9–10 (citing Ex. 1032, 1:6–9, 2:57–59, 5:51–60, 6:9–11, Fig. 4; Ex. 1002 ¶¶ 59–62, 104–107).

Patent Owner does not address Petitioner’s contentions or whether the preamble is limiting. *See* PO Resp. 21–43.

We have reviewed the evidence cited by Petitioner and find that Nerone discloses the subject matter of the preamble. Neither party contends that the preamble is limiting so we need not decide whether it is limiting.

[b] an LED circuit array comprising an LED circuit comprising a plurality of LEDs connected in series;

Petitioner contends that Nerone’s “circuit 400 (‘lighting system’) comprises an LED circuit array comprising a plurality of LEDs connected in series.” Pet. 11 (citing Ex. 1002 ¶ 108; Ex. 1031, Fig. 4). Petitioner provides the following annotated version of Nerone’s Figure 4 (*id.*):

IPR2022-00149
 Patent 10,687,400 B2

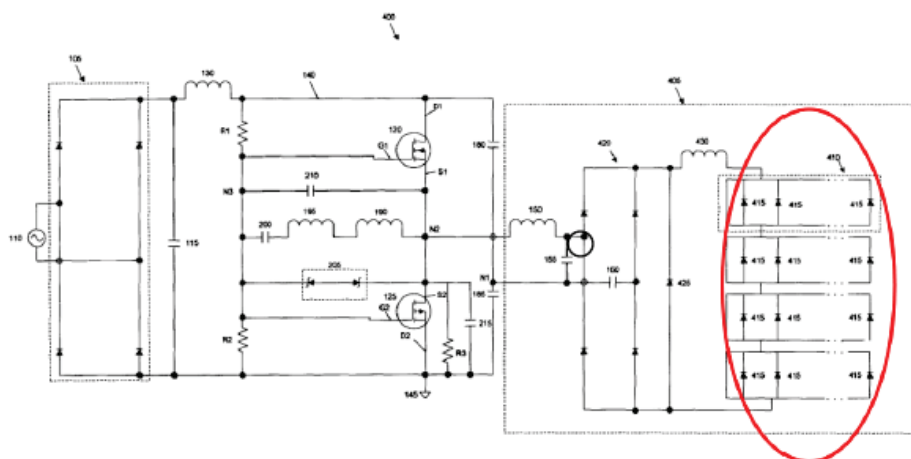

FIG. 4

Figure 4 of Nerone “is a schematic diagram of . . . [a] preferred embodiment of a power supply circuit.” Ex. 1032, 2:57–58. In this annotated version of Figure 4 of Nerone, Petitioner adds a red ellipse around LED group 410 on the right side of Figure 4. *Id.*

Petitioner contends Nerone discloses “that its LEDs circuit array [annotated in red] comprises an LED circuit (*i.e.*, groups 410) comprising a plurality of LEDs [415] connected in series.” Pet. 11–12 (citing Ex. 1002 ¶ 109); *see also id.* (“Nerone discloses that . . . ‘[t]he groups 410 of the LEDs 415 are connected in series.’” (citing Ex. 1032, 5:57–60)). Petitioner further contends that “[t]he arrangement of LEDs annotated in red above in Figure 4 of *Nerone* is an *LED circuit array*, *e.g.*, because *Nerone* explains that ‘[t]he present invention provides a more cost efficient electrical circuit for supplying power to an LED array.’” *Id.* (citing Ex. 1002 ¶ 110; Ex. 1032, 2:15–16).

Patent Owner provides the following annotated partial view of Figure 4 of Nerone:

IPR2022-00149
 Patent 10,687,400 B2

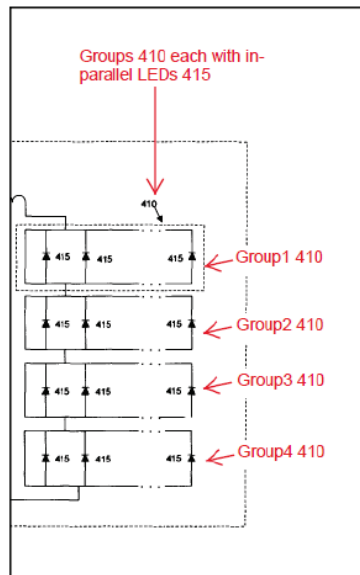

PO Resp. 23. In this diagram, Patent Owner provides the right-hand side of Figure 4 with red annotations identifying various groups of LEDs. *Id.*

Patent Owner contends that “[i]t is unclear whether the Petitioner is asserting that (1) each of the LED **groups** is in series, (2) the individual LEDs within a single group 410 are in series, or (3) the individual LEDs between the groups . . . are in series.” *Id.* at 22–23 (citing Ex. 1032, Fig. 4; Ex. 2001 ¶¶ 76–77).

Patent Owner contends that a person of ordinary skill in the art would have understood “that the ‘plurality of LEDs connected in series’ in limitation 7(b) refers to **individual LEDs** connected in series, not individual groups or circuits of LEDs being in series.” PO Resp. 24 (citing Ex. 1001, claim 7). Patent Owner further contends that “[t]he claim could have recited ‘a plurality of LED circuits connected in series’ but it does not.” *Id.* According to Patent Owner, “[w]hen the inventor wanted to claim circuits being connected in series or parallel, the claim expressly sets that forth, such as in limitation 14(b).” *Id.* (citing Ex. 1001, 28:15–16; Ex. 2001 ¶ 78).

IPR2022-00149
 Patent 10,687,400 B2

Patent Owner next contends that a person of ordinary skill in the art “would understand that Nerone’s groups 1-4 of LEDs 415 are not a ‘plurality of LEDs connected in series.’” PO Resp. 24. In support of this contention, Patent Owner provides the following drawing:

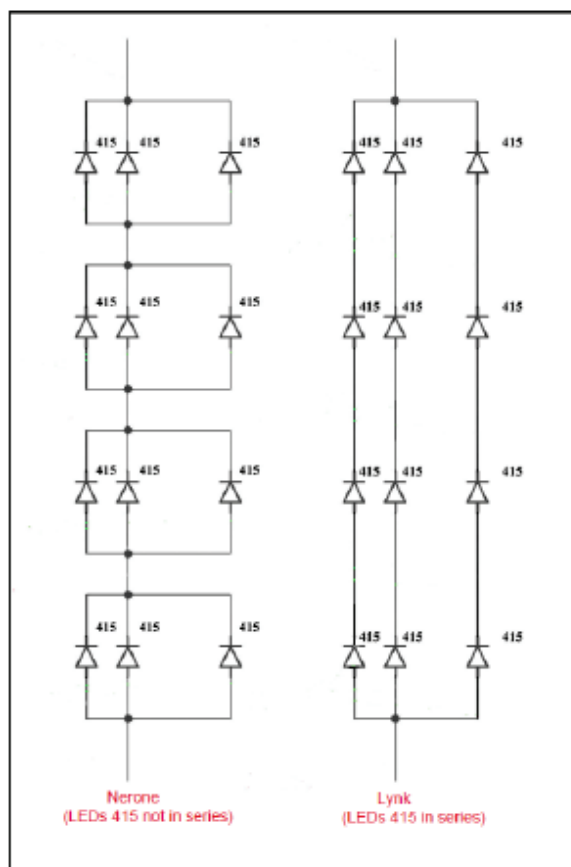

Id. In this diagram, Patent Owner provides two schematic diagrams inside a black box. *Id.* On the left side of the box, Patent Owner provides an excerpt from Figure 4 of Nerone with a red annotation “Nerone (LEDs 415 not in series).” *Id.* On the right side of the box, Patent Owner “depicts how the LEDs 415 of Nerone could have been configured (but were not) to be in series” with a red annotation “Lynk (LEDs 415 in series).” *Id.* at 23–24 (citing Ex. 2001 ¶ 79).

IPR2022-00149
Patent 10,687,400 B2

Patent Owner contends that “[e]ach of the **groups** 1-4 from Nerone is a circuit that is in series with the other groups. However, none of the individual LEDs 415 are connected in series with any other LEDs.” PO Resp. 26 (citing Ex. 2001 ¶ 80). Patent Owner contends that “Nerone confirms that each of the four groups 410 is in series, but the LEDs within the groups are not in series with LEDs within other groups.” *Id.* (citing Ex. 1032, 5:57–60). Patent Owner further contends that Figure 4 of Nerone confirms that there is “not one group that has any LED 415 connected in series to another LED within the group, nor is there any disclosure of an LED 415 in one group connected in series to an LED within another group.” *Id.* (citing Ex. 2001 ¶ 81).

Patent Owner next contends that “[t]he defining characteristic of a series circuit is that all components in the series circuit have the same current flowing through them.” PO Resp. 27 (citing Ex. 2007, 4). According to Patent Owner, “[t]he corollary is that if two components in a circuit can carry different currents, then those components cannot be in series.” *Id.* (citing Ex. 2001 ¶ 83). Based on this, Patent Owner argues that “individual LEDs 415 in groups 1-4 are not connected in series.” *Id.*; *see also id.* at 27–30 (arguing why LEDs in Nerone are allegedly not connected in series for the same reason); Sur-reply 3 (arguing that limitation 7(b) “refers to multiple LEDs having the same current path that carry the same current.”).

Patent Owner next contends that “the LEDs between the groups cannot be in series” because manufacturing tolerances may result in the LEDs 415 drawing different current. PO Resp. 29 (citing Ex. 2001 ¶ 86). Patent Owner contends that “an LED rated at 10 mA for a given forward

IPR2022-00149
Patent 10,687,400 B2

voltage may draw a little more or a little less, such as 10.0001 mA or 9.999 mA. *Id.*

Petitioner, in turn, reiterates its position from the Petition that Nerone discloses that its “**groups 410 of the LEDs 415 are connected in series.**” Pet. Reply 1 (citing Pet. 11–12). Petitioner contends that Patent Owner’s expert concedes, that, while LEDs *within* each group may be connected in parallel, the groups of LEDs are connected *in series.*” *Id.* (citing Ex. 2001 ¶¶ 81–82).

Petitioner next contends that “nothing in independent claim 14 (or other claims) implies that claim 7 excludes LEDs from parallel-connection to other LEDs.” Pet. Reply 2. Petitioner contends that Patent Owner “improperly imports a limitation into claim 7 and is inconsistent with the ’400 patent.” *Id.* at 3 (citing Ex. 1001, Figs. 6–8, 14, 21, 24; Ex. 1003 ¶¶ 3–16). Petitioner points to Figure 14 of the ’400 patent as “depict[ing] ‘a light emitting device 152 [including] a *series* opposing *parallel* LED matrix 154 and a capacitor 156 *connected in series.*’” *Id.* (citing Ex. 1001, 15:56–64, Fig. 14). Petitioner further contends that “matrix 154 . . . is described as including a ‘**series string of LEDs**’ . . . while each LED in a series string is also connected in parallel *to other* LEDs.” *Id.* (citing Ex. 1001, 1:64–16:1). Petitioner further contends that the series opposing parallel array of Figure 14 “is similar to the LED circuit array of Nerone.”

Petitioner provides the following annotated comparison of Figure 14 in the ’400 patent with Patent Owner’s partial annotated view of Nerone’s Figure 4:

IPR2022-00149
 Patent 10,687,400 B2

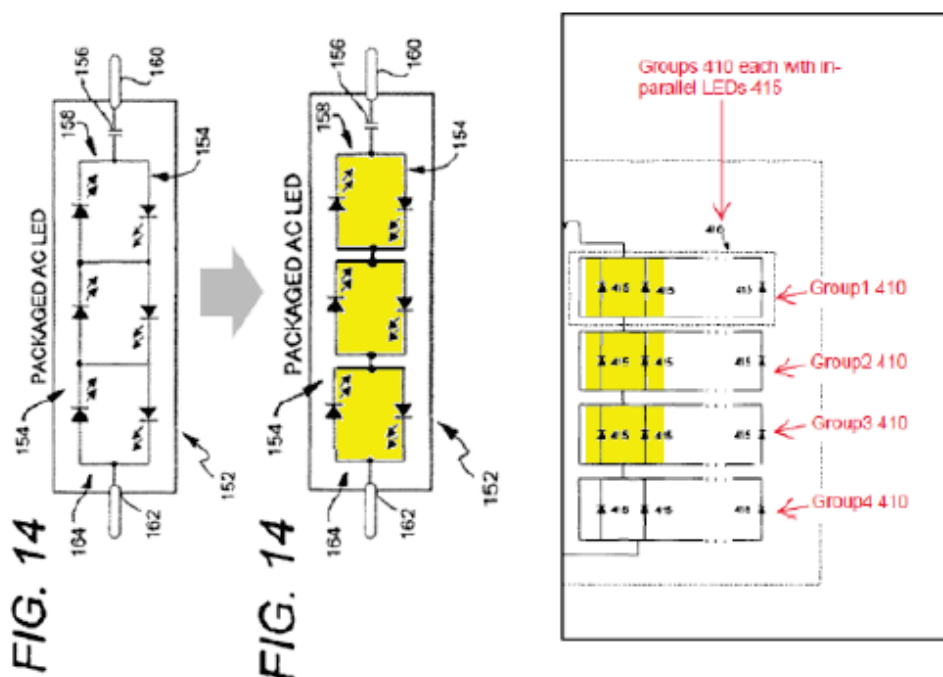

Id. at 4. This drawing shows Figure 14 rotated counterclockwise with yellow highlighting of certain nodes and Patent Owner’s partial annotated view of Figure 4 also with yellow highlighting of certain nodes. *Id.* (citing PO Resp. 23; Ex. 1001, Fig. 14; Ex. 1107 ¶¶ 14–15). Petitioner contends the highlighted nodes shown in Figure 4 of *Nerone* are “functionally identical” to the highlighted nodes in Figure 14 of the ’400 patent. *Id.* at 3. Petitioner further contends that Patent Owner “conceded that *Nerone*’s groups containing LEDs are connected in series *within an LED circuit* (POR, 24) which necessarily means that the LEDs of each group are ‘connected in series’ with the LEDs *of the other groups*.” *Id.* at 4 (citing Ex. 1107 ¶¶ 10–13).

Petitioner next contends that Patent Owner’s “reliance on ‘manufacturing tolerances’ is misplaced.” Pet. Reply 10 (citing PO Resp. 29–30). Petitioner argues that Patent Owner “presents no evidence that a [person of ordinary skill in the art] would have considered ‘manufacturing

IPR2022-00149
Patent 10,687,400 B2

tolerances' relevant to" whether LEDs are connected in series or parallel. *Id.* (citing Ex. 2001 ¶ 86). Petitioner further contends that "[w]hatever miniscule differences might exist they would apply equally to LEDs connected in series regardless of other parallel connections and thus have no bearing on limitation 7(b)." *Id.* (citing Ex. 1107 ¶¶ 25–26).

For the following reasons, we are persuaded that Nerone discloses this limitation.

As discussed above, Petitioner contends that Nerone's "LED circuit array . . . comprises an LED circuit, (*i.e.* groups 410) comprising a plurality of LEDs connected in series." Pet. 11 (citing Ex. 1032, Fig. 4). Patent Owner does not dispute Petitioner's contentions concerning Nerone's teaching of an LED circuit array and an LED circuit. *Compare* Pet. 11, *with* PO Resp. 21–30. But, Patent Owner contends that Petitioner's mapping of Nerone to this claim limitation is unclear. PO Resp. 22–23. We disagree because the Petition states that Nerone's "**groups 410 of the LEDs 415 are connected in series.**" Pet. 11–12 (citing Ex. 1032, 5:57–60); Pet Reply 1 (citing Pet. 11–12). Patent Owner admits that "Nerone confirms that each of the four groups 410 is in series." PO Resp. 26; *see also* Ex. 2001 ¶ 81 (Dr. Ducharme testifying that "each of four groups 410 is in series."). Consequently, because there is no dispute that groups 410 are in series, the question we must resolve is whether Nerone's groups 410 meet the requirement of "a plurality of LEDs connected in series" as recited in limitation 7(b).

Patent Owner's contentions are largely based on rewriting this limitation. Patent Owner argues that a person of ordinary skill in the art "would understand that the 'plurality of LEDs connected in series' in

IPR2022-00149
Patent 10,687,400 B2

limitation 7(b) refers to **individual LEDs** connected in series.” PO Resp. 24; *see also* Sur-reply 2 (“at least two **LEDs** are connected in series”). But, limitation 7(b) does not recite “individual LEDs connected in series.” Dr. Ducharme repeats verbatim the Patent Owner’s arguments concerning the meaning of limitation 7(b). Ex. 2001 ¶ 78. Dr. Baker counters that a person of ordinary skill would have understood the “meaning of limitation 7(b) . . . to encompass an LED circuit array that includes at least one LED circuit that includes two or more LEDs that are connected in series . . . but not exclude that the ‘LED circuit’ can have other LED(s) connected in parallel.” Ex. 1107 ¶ 4. For the reasons explained below, we credit Dr. Baker’s testimony over that of Dr. Ducharme because it is more consistent with the claim language.

Limitation 7(b) recites, in its entirety, “an LED circuit array comprising an LED circuit comprising a plurality of LEDs connected in series.” Ex. 1001, 27:49–50. Although two or more individual LEDs connected in series could satisfy this limitation, the scope is broader than Patent Owner contends because the plurality of LEDs connected in series are part of an LED circuit that is part of an LED circuit array. Patent Owner’s reference to claim 14 (PO Resp. 24) does not support its reading of claim 7. Claim 14 recites “LED circuits connected in parallel, wherein each LED circuit comprises at least two LEDs.” This language sheds little, if any, light on the meaning of “a plurality of LEDs connected in series.” To the extent that Patent Owner’s contentions for this limitation are based on limiting the scope of limitation 7(b) to individual LEDs connected in series, those contentions are unavailing.

IPR2022-00149
Patent 10,687,400 B2

To be clear, we find that Nerone discloses that resonant load circuit 405 “includes at least one group 410 of LEDs 415 connected in parallel and polarized in the same direction” and “groups 410 of the LEDs 415 *are connected in series.*” Ex. 1032, 5:58–60 (emphasis added).

Patent Owner’s analysis ignores Petitioner’s contention that Nerone’s LED circuit comprises “groups 410.” Pet. 11. Rather, Patent Owner applies its narrow construction within individual groups 410. For example, Patent Owner argues that “individual LEDs 415 in groups 1-4 are not connected in series” and, that if one LED in a group fails, then current will still flow through the remaining LEDs in the group. According to Patent Owner, this means the LEDs within the group are *not* in series. PO Resp. 27–29.

However, this is where Patent Owner’s argument about current flow through series connected LEDs fails. We agree with Petitioner and Dr. Baker, that in the case of a failure of one LED in one of Nerone’s groups 415, current still flows “because *the group includes* parallel connected LEDs—not because the LEDs *between* the groups are not connected in series. Pet. Reply 7 (citing Ex. 1107 ¶¶ 12, 20). The fact that individual LEDs in any group 415 are not connected in series is not dispositive. Limitation 7(b) requires “an LED circuit comprising a plurality of LEDs connected in series.” Ex. 1001, 27:49–50. We find that any two adjacent groups 410, which are part of the LED circuit in Nerone, correspond, to “a plurality of LEDs connected in series.”

With respect to Patent Owner’s manufacturing tolerance issue, Patent Owner relies on Dr. Ducharme’s testimony. Dr. Ducharme testifies that a person of ordinary skill in the art would have known of manufacturing tolerances, but he does not testify that the ordinary skilled artisan would

IPR2022-00149
Patent 10,687,400 B2

understand that manufacturing tolerances affect whether LEDs are connected in series. Ex. 2001 ¶ 86. In point of fact, Dr. Baker testifies that “a person of ordinary skill in the art would not have attributed such characteristics [manufacturing tolerances] to understanding whether *Nerone*’s array includes LEDs connected in series, or whether in general, LEDs are connected in series or parallel.” Ex. 1107 ¶ 25. Based on Dr. Baker’s testimony, which we credit, any manufacturing tolerances of the LEDs in *Nerone*’s groups 410 have no bearing on whether groups 410 are connected in series.

After reviewing Petitioner’s contentions and the evidence in the record and Patent Owner’s contentions, we find that *Nerone* discloses this limitation.

[c] a capacitor

Petitioner contends that “*Nerone* discloses that circuit 400 (‘lighting system’) includes capacitors 115, 155, 160, 185, 200, 210, and 215 (red below), any of which is ‘a capacitor.’” Pet. 12–13 (citing Ex. 1032, Fig. 4; Ex. 1002 ¶ 111). Petitioner provides the following annotated version of *Nerone*’s Figure 4 in support of this contention (*id.* at 13):

IPR2022-00149
 Patent 10,687,400 B2

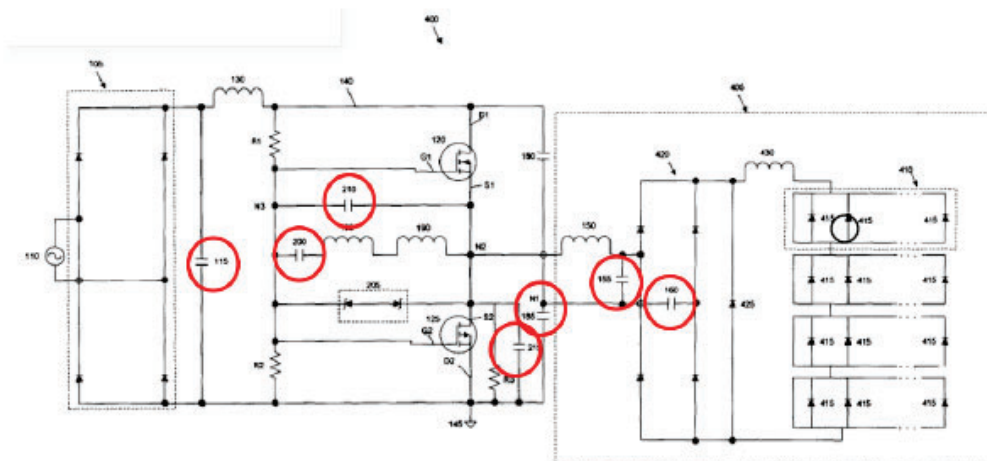

FIG. 4

In this annotated version of Nerone's Figure 4, Petitioner adds red circles around item numbers 115, 155, 160, 185, 200, 210, and 215 that it contends are capacitors.

Patent Owner does not address Petitioner's contentions. *See* PO Resp. 21–43.

Based on our review of the evidence cited by Petitioner, we find that Nerone discloses this limitation.

[d] a bridge rectifier configured to receive an input AC voltage from a mains power source;

Petitioner contends that “Nerone in view of the state of the art discloses or suggests this limitation.” Pet. 13 (citing Ex. 1002 ¶¶ 112–115). Petitioner contends Nerone discloses circuit 400 comprises bridge rectifier 105 configured to receive an input AC voltage. *Id.* (citing Ex. 1002 ¶ 112). In support of this contention, Petitioner provides the following annotated version of Nerone's Figure 4 (*id.* at 14):

IPR2022-00149
 Patent 10,687,400 B2

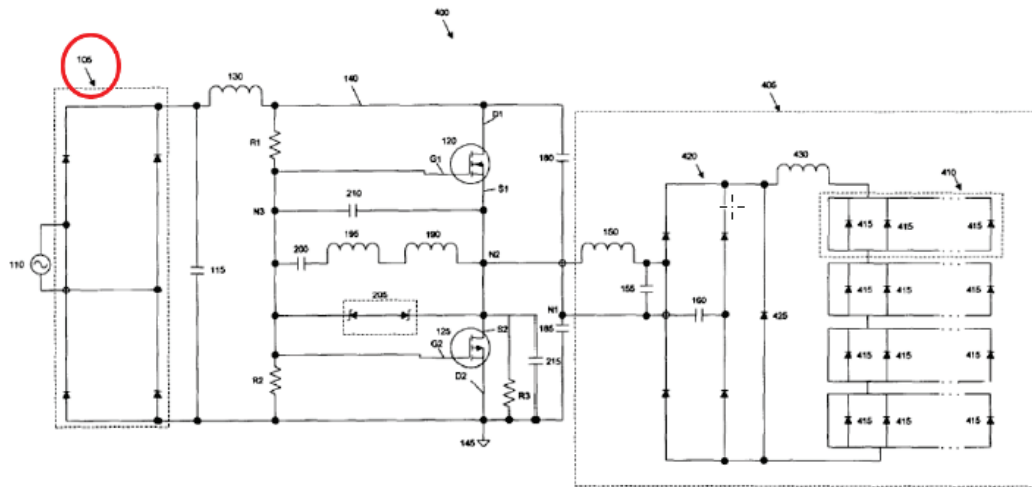

FIG. 4

In this annotated version of Figure 4, Petitioner adds a red circle around item number 105 in the upper left-hand corner which it contends is bridge rectifier 105. *Id.*

Petitioner contends that Nerone's bridge rectifier 105 is configured to receive an input AC voltage from AC source 110. Pet. 14 (citing Ex. 1002 ¶ 113; Ex. 1032, 2:65–67). Petitioner asserts that because Nerone's lamps "operate with a 120 volt 60 Hz AC power supply[] . . . [a skilled artisan] would have known that an AC voltage of 120 V (*i.e.*, 120 VAC) was commonly available from a mains power source." *Id.* at 15 (citing Ex. 1002 ¶ 114; Ex. 1032, 1:51–56; Ex. 1027, 1:8–12, 1:18–27; Ex. 1045, 1:20). According to Petitioner, a skilled artisan "would have been motivated and found it obvious to configure *Nerone's* bridge rectifier 105 to receive its input AC voltage from a *mains* power source." *Id.* (citing Ex. 1002 ¶ 115).

Patent Owner does not address Petitioner's contentions. *See* PO Resp. 21–43.

IPR2022-00149
Patent 10,687,400 B2

Based on our review of the evidence cited by Petitioner, we find that Nerone suggests this limitation.

[e] a driver connected to the bridge rectifier and configured to provide a rectified output AC voltage to the LED circuit array;

Petitioner contends that “Nerone discloses a driver . . . connected to bridge rectifier 105 (‘the bridge rectifier’) and configured to provide a rectified output AC voltage to the LED circuit array.” Pet. 16 (citing Ex. 1032, Fig. 4; Ex. 1002 ¶ 116). In support of this contention, Petitioner provides the following annotated version of Nerone’s Figure 4 (*id.*):

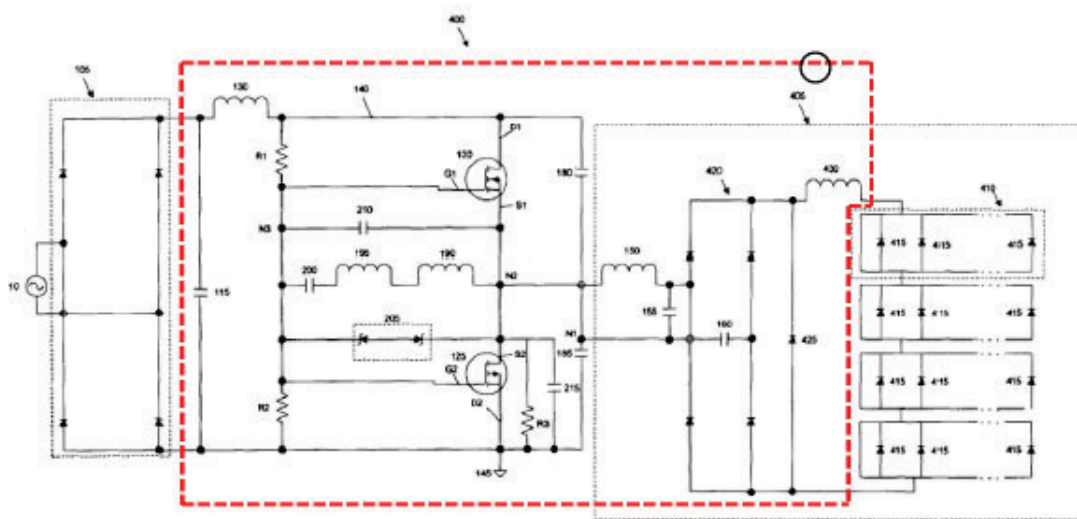

FIG. 4

In this annotated version of Figure 4, Petitioner provides a red rectangle drawn with broken lines around the items it contends correspond to the recited driver. *Id.* Petitioner contends that “[t]he circuitry annotated in red . . . is a *driver*, e.g., because it drives current and power to the LED circuit array.” *Id.* (citing Ex. 1002 ¶ 117). According to Petitioner, “the bridge rectifie[r] allows both halves of the input AC voltage waveform to pass

IPR2022-00149
Patent 10,687,400 B2

through the lamp in the same current direction . . . , thus producing a rectified AC voltage waveform output.” *Id.* at 17 (citing Ex. 1002 ¶ 117).

Patent Owner does not address Petitioner’s contentions. *See* PO Resp. 21–43.

Based on our review of the evidence cited by Petitioner, we find that Nerone discloses this limitation.

[f] wherein a forward voltage of the LEDs of the LED circuit array matches the rectified input AC voltage output of the driver; and

Petitioner contends that to the extent Nerone does not disclose that the forward voltage of the LEDs matches the rectified input AC voltage, “it would have been obvious in view of Martin and the state of the art to configure Nerone’s circuit 400 (‘lighting system’) system to provide such features to ensure proper operation of the LED circuitry . . . in circuit 400.” Pet. 18–19 (citing Ex. 1002 ¶¶ 63–65, 119–131). Petitioner contends that a person of ordinary skill in the art “would have understood and taken into account the following considerations:

(a) the total voltage drop of the circuit would dictate the current drawn by the LED circuitry, which would have been known to be inversely proportional to the voltage; (b) fewer LEDs in the design would lead to a larger current compared to a circuit with a greater number of LEDs; (c) excessive current would have been harmful to Nerone’s LEDs that could lead to failure; (d) too small a current may be insufficient to power the LEDs in a manner that enabled the lighting device [to] operate as intended.

Id. at 19 (citing Ex. 1002 ¶ 120).

Petitioner further contends that a skilled artisan knowledgeable about typical LED circuit design “would have taken into consideration the number of LEDs and the total voltage drop of the LED circuit when designing and

IPR2022-00149
Patent 10,687,400 B2

implementing *Nerone*'s circuit 400" and that "matching the input voltage to the forward voltage of the LEDs had become a matter of routine optimization." *Id.* at 19–20 (citing Ex. 1002 ¶¶ 120–121; Ex. 1074 ¶ 30).

Petitioner next contends Martin discloses "that '[e]xcessive forward voltage can damage the LEDs irreversibly' and that '[s]eries interconnection reduces the voltage drop across each LED to a level that does not exceed the maximum forward voltage of each LED.'" Pet. 20 (citing Ex. 1015 ¶ 21). Petitioner further contends Martin is similar to the '400 patent and *Nerone* because it "relates to monolithic arrays of semiconductor light emitting devices powered by alternating current sources." *Id.* (citing Ex. 1001, codes (12), (57); Ex. 1015 ¶ 2, Fig. 5). Petitioner further contends "*Martin* discloses that '**[t]he number of LEDs in the monolithic array may be selected to achieve a particular voltage drop across each device . . . such that the maximum voltage across each individual LED during the peak in the alternating current cycle is low enough so as to not damage the LEDs.**'" *Id.* (citing Ex. 1015 ¶ 22). Petitioner further contends Martin "explains that '[t]he voltage across each of the individual LEDs in the array is the line voltage divided by the number of LEDs in series.'" *Id.* (citing Ex. 1002 ¶ 123; Ex. 1015 ¶ 22). According to Petitioner, this "applies equally to LEDs powered directly from an alternating current . . . as well as those powered by rectified AC current (where the LEDs are powered on continuously)." *Id.* at 21 (citing Ex. 1002 ¶ 124; Ex. 1015 ¶¶ 23–24, Fig. 5). Based on the teachings of Martin, Petitioner contends a skilled artisan "would have recognized that the forward voltage of [*Nerone*'s] series-connected LEDs should [have] approximately matched the rectified AC

IPR2022-00149
Patent 10,687,400 B2

voltage output of the above-described LED driver circuit.” *Id.* (citing Ex. 1002 ¶ 124).

Petitioner also contends that combining the teachings of Nerone and Martin “is consistent with the state of the art.” Pet. 22 (citing Ex. 1002 ¶ 125). In particular, Petitioner analyzes Allen (Ex. 1011) and Bockle (Ex. 1075) as representative of the state of the art. *Id.* at 22–24. According to Petitioner, based on the alleged knowledge of a skilled artisan and Nerone and Martin, a skilled artisan “would have had the skills and rationale to consider and implement the above modification and would have done so with a reasonable expectation of success.” *Id.* at 26 (citing Ex. 1002 ¶ 130).

Patent Owner first contends that Petitioner fails to analyze “what would be the value of the DC output voltage at the inductor 430 of Nerone’s Figure 4 based on an input voltage of 120 VAC” and “does not indicate the number of LEDs 415 or the number of groups 410 in Nerone’s figure 4 that would be necessary to match the (unspecified) DC voltage output.” PO Resp. 31–32 (emphasis omitted).

Patent Owner next contends that Martin attempts to avoid damaging LEDs and “proposes a ‘[s]eries interconnection [that] reduces the voltage drop across each LED to a level that does not exceed the **maximum forward voltage** of each LED. Excessive forward voltage can damage the LEDs irreversibly.” PO Resp. 33 (quoting Ex. 1015 ¶ 21). Patent Owner further contends that “[f]or a 120 VAC input, Martin discloses selecting the number of LEDs to be 38 LEDs so that the voltage drop across each LED is less than the ‘maximum forward voltage’ of 4.5 V at the voltage peak of 169.71 V.” *Id.* (citing Ex. 1005 ¶ 21; Ex. 2001 ¶ 92). According to Patent Owner “[t]he claimed voltage-matching provides that the total voltage drop

IPR2022-00149
Patent 10,687,400 B2

across the LEDs matches the rectified voltage delivered by the driver” but “Martin . . . is teaching that the voltage across individual LEDs is less than a maximum voltage to *prevent damage* from overdriving LEDs, not matching LED drops to a rectified AC voltage from a driver.” *Id.* at 33–34 (citing Ex. 2001 ¶ 93).

Patent Owner next contends that Martin teaches selecting 42 LEDs for a circuit “where each LED operates at its ‘forward voltage’ of 3.5 V for a total voltage drop of $42 \times 3.5 \text{ V} = 147 \text{ V}$.” PO Resp. 34 (citing Ex. 1015 ¶ 22; Ex. 2001 ¶ 94) (footnote omitted). Patent Owner contends that the “147 V drop does not match the rectified AC voltage” because “[a] voltage drop of 147 V is much less than the peak voltage of 169.71 V. A voltage drop of 147 V is much more than the rms voltage of 120 V.” *Id.* (citing Ex. 2001 ¶ 95).

Patent Owner next contends that Martin does not meet the recited voltage matching because it “selects the number of LEDs based on an **unrecitified AC voltage** with a peak of 169.71 V, not based on a **rectified AC voltage**” as recited in limitation 7(f). PO Resp. 35 (citing Ex. 2001 ¶ 96). Patent Owner concedes that Figure 5 of Martin discloses LEDs driven by a rectified AC voltage but contends that the rectified voltage in Figure 5 would be 168.31 V. *Id.* at 35–36 (citing Ex. 1015, Fig. 5; Ex. 2001 ¶ 97). According to Patent Owner, Martin does not “teach selecting the number of LEDs based on a rectified AC voltage of 168.31 V.” *Id.* (citing Ex. 1015 ¶ 24, Fig. 5; Ex. 2001 ¶ 98).

Patent Owner next contends that the circuit in Nerone’s Figure 4, “delivers a fixed DC voltage (rectified AC voltage) to LED groups 410 using a second full wave bridge rectifier 420 and current limiting conductor

IPR2022-00149
Patent 10,687,400 B2

430” switches 420/425 and the resonant load circuit 405 regulate the amount of voltage and current delivered to the LED groups 410.” PO Resp. 36–37. According to Patent Owner, based on this, “there is no need to select the number of LEDs in groups 410 to match their total forward voltage drop to the DC voltage at inductor 430.” *Id.* at 37.

Patent Owner next contends that Petitioner “cites to four inappropriate extraneous references not part of Ground 1.” PO Resp. 38 (citing Pet. 20, 23–25; Ex. 1012 ¶¶ 121, 125–127, 129; Ex. 1011 (“Allen”); Ex. 1014 (“Birrell”); Ex. 1074 (“Cross”); Ex. 1075 (“Bockle”)). Patent Owner further contends that “Petitioner defined its ground based on Nerone and Martin and should not be permitted to modify or effectively create a new ground that includes these four additional references.” *Id.* at 38–39.

Patent Owner does not dispute Petitioner’s contentions concerning reasonable expectation of success. *Compare* Pet. 26, *with* PO Resp. 30–43.

Petitioner, in turn, contends that Patent Owner “does not dispute, or proffer any refuting evidence concerning, the Petition’s analysis and supporting evidence . . . that the ‘matches’ requirement was an *obvious matter of routine configuration/optimization* in the art.” Pet. Reply 12 (citing Pet. 19–20, Ex. 1002 ¶¶ 120–12, Ex. 1074 ¶ 30).

Petitioner contends that the obviousness analysis does not require Petitioner to provide “some *specific number* of LEDs and output voltage for the modified *Nerone* system.” Pet. Reply 13 (citing *KSR*). Petitioner further contends the number of LEDs “would have depended on the *particular* output voltage, LEDs, and application” and “[a]s a matter of routine skill, the precise number of LEDs would have been optimized for the chosen

IPR2022-00149
Patent 10,687,400 B2

application to avoid, *e.g.*, overdriving.” *Id.* (citing Ex. 1002 ¶¶ 41–43, 63–65, 119–131; Ex. 1107 ¶¶ 28–29).

Petitioner next contends that Patent Owner “avoids defining ‘matches’ or comparing the ’400 patent, including its description of ‘matched’ forward voltage from [Ex. 1011].” Pet. Reply 13–14. Petitioner cites to the ’400 patent’s description of Allen’s voltage matching requirement as “the peak input voltage must be less than or equal to the sum of the maximum forward voltages . . . in order to prevent over-driving.” *Id.* at 14 (citing Ex. 1001, 2:27–35). Petitioner further contends that Dr. Ducharme testified “that ‘matches’ requires *exactly equal* output voltage and total voltage drop of the LEDs” which according to Petitioner is “inconsistent with the ’400 patent’s description of ‘match’ as a ‘**less than or equal to**’ condition.” *Id.* at 14–15 (citing Ex. 1001, 2:27–35; Ex. 1106, 23:25–25:9; Ex. 1107 ¶¶ 27–28). Petitioner further contends that “the ’400 patent describes using matching to prevent overdriving which is the same as Martin’s reason for matching. *Id.* at 15 (citing Ex. 1001, 2:27–35, 3:11–33, 8:16–46, 16:64–17:7).

Petitioner next contends that Patent Owner’s attempt to distinguish Martin because Figure 4 supplies an AC voltage not a rectified AC voltage is unavailing. Pet. Reply 15 (citing PO Resp. 35). Petitioner further contends that Patent Owner “fails to show any impact these examples had on a [person of ordinary skill in the art]’s ability or desire to ‘match the output voltage’ but, in any event, according to Petitioner, Martin “exemplifies driving with a rectified AC voltage.” *Id.* (citing Pet. 20–21; Ex. 1015 ¶¶ 23–25, Fig. 5; Ex. 1011 ¶¶ 41–43; Ex. 1074 ¶ 30; Ex. 1107 ¶¶ 29–30).

Petitioner further contends that Cross, Allen, Bockle, and Birrell were cited to corroborate Dr. Baker’s testimony concerning the knowledge of a

IPR2022-00149
Patent 10,687,400 B2

person of ordinary skill in the art as “to matching.” Pet. Reply 18 (citing Pet. 19–26; Ex. 1002 ¶¶ 36, 40–44, 65, 119–131). Petitioner further contends that it is not using these references for “gap-filling” or combining any of Cross, Allen, Bockle, or Birrell with Nerone or Martin. *Id.* (citing Pet. 18–27).

In the Sur-reply, Patent Owner contends Petitioner statement in the Reply that the number of LEDs in the modified Nerone system is a matter of routine skill in the art based on various factors is “vague and conclusory” and “does not remotely establish that Nerone/Martin meets limitation 7(f).” Sur-reply 12–13.

Patent Owner next contends that it did not overlook “the example in Martin’s paragraph [0022] where the 38 LEDs are connected in series.” Sur-reply 13 (citing PO Resp. 33–34; Ex. 2001 ¶ 93). Patent Owner further contends that “[t]his example is distinguishable because the selection of LEDs is based on a direct drive AC input voltage, not the ‘rectified [] AC voltage output of the driver’ per limitation 7(f)” and “because the LEDs are selected based on the LEDs **maximum forward voltage**, not based on their forward voltage, as a [person of ordinary skill in the art] would understand for limitation 7(f).” *Id.* (citing Ex. 1015 ¶ 22).

For the following reasons, Petitioner persuades us that the combined teachings of Nerone and Martin suggest this limitation.

Patent Owner’s contentions are based on the premise that “matches means an equivalence within a manufacturing tolerance.” Tr. 32:18–21; *see also* PO Resp. 33–34 (“Martin . . . is teaching that the voltage across individual LEDs is less than a maximum voltage to *prevent damage* from overdriving LEDs, not matching LED drops to a rectified AC voltage from a

IPR2022-00149
Patent 10,687,400 B2

driver.” (citing Ex. 2001 ¶ 93)). The ’400 patent describes “for the forward voltage to be ‘matched,’ in each series block, the peak input voltage must be *less than or equal to* the sum of the maximum forward voltages for each series block in order to prevent over-driving.” Ex. 1001, 2:32–35 (emphasis added); *id.* at 9:49–51 (“opposing parallel series strings of LEDs connected together and driven direct with a high frequency AC voltage equal to or less than the total series voltage drop of the opposing parallel strings of LEDs.”); *id.* at 16:64–17:7 (“in a lighting device that is run off 120 V source and contains LEDs having a forward operating voltage of 3V each connected to a bridge rectifier . . . approximately 38 LEDs may be placed in series to drop the required voltage.”). While matching based on “an equivalence within a manufacturing tolerance” falls within the scope of limitation 7(b), the ’400 patent’s description of “matches” is broader than “equivalence.” It also encompasses “the rectified input AC voltage output of the driver” that is less than “a forward voltage of the LEDs of the LED circuit.” *See* Ex. 1001, 2:32–35. Consequently, Patent Owner’s contentions that “Martin . . . is teaching that the voltage across individual LEDs is less than a maximum voltage . . . not matching” (PO Resp. 33–34), and the “voltage drop of 147 V is much less than the peak voltage” (PO Resp. 34) are unavailing.

We also do not agree with Patent Owner that Petitioner is required to provide a specific numerical analysis of the number of LEDs necessary to match a value of the DC output voltage in Nerone. PO Resp. 31–32. Based on Dr. Baker’s testimony, Petitioner provides several factors that a person of ordinary skill in the art would have considered when designing Nerone’s circuitry to satisfy the “matching” requirement of limitation 7(f). Pet. 18 (citing Ex. 1002 ¶ 120). Dr. Baker supports his testimony concerning the

IPR2022-00149
Patent 10,687,400 B2

knowledge of these factors by one of ordinary skill with reference to disclosures in Cross and Martin. Ex. 1002 ¶¶ 121–123. Neither Patent Owner nor Dr. Ducharme dispute that a person of ordinary skill in the art would have known to consider these factors when designing Nerone’s circuit. See PO Resp. 30–43; Ex. 2001 ¶¶ 89–106. Petitioner then explains how a person of ordinary skill in the art would have used these factors to apply the teachings of Martin to configure Nerone’s circuitry so that “the forward voltage of the series-connected LEDs [] approximately match[es] the rectified AC voltage output of the above-described LED driver circuit.” Pet. 21; *id.* at 20–21; *see also* Ex. 1107 ¶ 29 (“a person of ordinary skill in the art would have understood and would have been capable of determining the appropriate number of LEDs based on the application and design of Nerone’s system such that the forward voltage drop of the LEDs . . . matches the rectified AC voltage output . . . to mitigate against overdriving or underdriving the LEDs.” (citing Ex. 1074 ¶¶ 30–31, Fig. 2)). For these reasons, we find that it was not necessary for Petitioner to provide a specific numerical calculation of the number of LEDs in its proposed modification of Nerone.

We also agree with Petitioner that “matching the input voltage to the forward voltage of the LEDs had become a matter of routine optimization.” Pet. 19. Patent Owner contends that this statement is “vague and conclusory.” Sur-reply 12–13. Petitioner, however, supports this statement with the testimony of Dr. Baker. Ex. 1002 ¶¶ 120–123. Dr. Baker’s testimony, which we credit, is corroborated by both Cross and Martin. See *id.* (citing Ex. 1015 ¶¶ 2, 21, 22 Fig. 5; Ex. 1074 ¶ 30). In particular, Cross specifically discloses that “[t]he number of LEDs employed will vary with

IPR2022-00149
Patent 10,687,400 B2

the intended lighting application and the value of the rectified DC voltage, wherein *optimization of such is well within the skill of those in the art.*”

Ex. 1074 ¶ 30. Patent Owner does not dispute Cross’s statement that optimizing the number of LEDs is within the skill of an ordinarily skilled artisan. *See* PO Resp. 40.

Martin chooses the number of LEDs “such that the maximum voltage across each individual LED . . . is low enough so as to not damage the LEDs.” Ex. 1015 ¶ 22. It also specifically discloses that “[t]he voltage across each of the individual LEDs in the array is the *line voltage divided by the number of LEDs in series.*” *Id.* (emphasis added). Consequently, Martin uses “voltage matching” to determine the number of LEDs so as not to damage the individual LEDs. *See also* Ex. 1002 ¶¶ 120–124 (Dr. Baker explaining that a skilled artisan “configuring *Nerone*’s circuit 400 would have recognized that the forward voltage of the series-connected LEDs should approximately match the rectified AC voltage output of the above-described LED driver circuit.” *Id.* ¶ 124.). Martin’s disclosure, thus, aligns with the reason for “matching” described in the ’400 patent. Ex. 1001, 2:24–35.

We also disagree with Patent Owner that Petitioner is using any of Cross, Allen, Bockle, or Burrell for gap filling. As just discussed, these references are used to corroborate Dr. Baker’s testimony concerning the knowledge of a person of ordinary skill in the art, *e.g.*, Cross’s disclosure that optimization is within the skill of one of ordinary skill in the art.

We have reviewed Petitioner’s contentions and evidence, and after considering all of Patent Owner’s contentions, we find that the combined teachings of *Nerone* and Martin teach or suggest limitation 1(f). Further,

IPR2022-00149
Patent 10,687,400 B2

Petitioner persuades us that a person of ordinary skill in the art would have been motivated to combine Nerone and Martin and would have had a reasonable expectation of success in doing so. As discussed above, the optimization of LED strings by matching LEDs to input voltage was within the knowledge of one of ordinary skill in the art as evidenced by Martin and corroborated by Cross, and thus, we find that the '400 "patent simply arranges old elements with each element performing the same function it had been known to perform and yields no more than one would expect from such an arrangement [and] the combination is obvious." *KSR* 550 U.S. at 417.

[g] wherein the LED circuit array, the capacitor, the bridge rectifier, and the driver are all mounted on a single substrate.

Petitioner contends that Nerone discloses this limitation because Nerone discloses that "[a]ll of the circuit components may be placed on the same circuit board as the light emitting elements." Pet. 27 (citing Ex. 1032, code (57); *see also* Ex. 1002 ¶¶ 132–134). According to Petitioner, Nerone's broad disclosure applies to each of the embodiments such that Nerone's LED circuit array, various capacitors, bridge rectifier 105, and driver "are all mounted on a single circuit board ('single substrate')." Pet. 28 (citing Ex. 1002 ¶ 133).

Patent Owner does not address Petitioner's contentions. *See* PO Resp. 21–43.

Based on our review of the evidence cited by Petitioner, we find that Nerone discloses this limitation.

Summary of Claim 7

For all the foregoing reasons, we determine Petitioner establishes by a preponderance of the evidence that claim 7 is unpatentable over Nerone and Martin.

IPR2022-00149
Patent 10,687,400 B2

4. *Claim 9*

Claim 9 depends from claim 7 and recites “wherein the LEDs are coated or doped with at least one of a phosphor, nanocrystals, or a light changing or enhancing substance.” Ex. 1001, 27:65–67.

Petitioner details the disclosure in Martin that it contends corresponds to the limitations in claim 9. Pet. 28–29 (citing Ex. 1002 ¶ 136; Ex. 1015 ¶¶ 5, 27). Petitioner further provides reasons why it would have been obvious to a person of ordinary skill in the art “to coat the LEDs of *Nerone*’s system with a phosphor or wavelength converting material.” *Id.* at 29 (citing Ex. 1002 ¶ 137; Ex. 1038 ¶ 42).

For claim 9, Patent Owner relies on its contentions for claim 7. *See* PO Resp. 43.

Based on our review of the evidence cited by Petitioner, we find that *Nerone* discloses this limitation and determine that Petitioner establishes by a preponderance of the evidence that claim 9 is unpatentable over *Nerone* as modified by Martin for claim 7.

5. *Claim 11*

Claim 11 depends from claim 7 and recites “wherein the capacitor is configured to smooth the rectified output AC voltage.” Ex. 1001, 28:5–6.

Petitioner contends that “*Nerone*’s capacitor 160 is “configured to smooth the rectified output AC voltage,” because it “affects how the resonant inductor 150 and resonant capacitor 155 network perceives the impedance of the LEDs” and “may limit the current through the LEDs.” Pet. 30 (citing Ex. 1032, 3:28–29). According to Petitioner, “matching capacitor 160 ‘smooth[s]’ the voltage waveform” because “current and voltage are directly related (Ohm’s Law), restricting the peaks and valleys of the current

IPR2022-00149
Patent 10,687,400 B2

likewise limits the peaks and valleys of the voltage waveform.” *Id.* (citing Ex. 1002 ¶¶ 138–140).

Patent Owner responds that Nerone’s capacitor 160 is part of the “driver” identified by Petitioner. Pet. 44 (citing Pet. 16; Ex. 2001 ¶ 108); Sur-reply 18–19. According to Patent Owner, because capacitor 160 is part of the “driver”, “it is not **connected to** the driver as called for in Claim 11.” *Id.* at 44–45. Patent Owner next contends that capacitor 160 functions “to ‘affect[] how the resonant inductor 150 and resonant capacitor 155 network perceives the impedance of the LEDs 170, 175’ . . . meaning that its value is selected to tailor impedance of the load (LEDs 170, 175) to match the resonant load network (150, 155).” *Id.* at 45 (citing Ex. 1032, 3:35–37).

Petitioner replies that “claim 11 *does not recite* that the capacitor is ‘connected to the driver.’” Pet. Reply 19 (citing PO Resp. 44–45). Petitioner further contends that Patent Owner “does not explain why selecting a particular value for the capacitor precludes smoothing” but “seems to concede that matching capacitor 160 is configured to smooth the AC signal into the second bridge rectifier 420 . . . and hence the rectified AC signal output by the rectifier.” *Id.* (citing PO Resp. 45–46).

For the following reasons, Petitioner persuades us that claim 11 would have been unpatentable in light of Nerone and Martin.

Patent Owner’s contention that claim 11 requires the capacitor to be connected to the driver is unsupported by the claim language. Neither claim 11 nor claim 7 require the capacitor to be connected to the driver. Ex. 1001, 27:48–27:62, 28:5–6.

Nerone discloses that capacitor 160 “affects how the resonant inductor 150 and resonant capacitor 155 network perceives the impedance of the

IPR2022-00149
Patent 10,687,400 B2

LEDs” and “may limit the current through the LEDs.” Ex. 1032, 3:25–29. Dr. Baker testifies that, considering Ohm’s Law, this disclosure means “the matching capacitor 160 ‘smooth[s]’ the voltage waveform.” Ex. 1002 ¶ 138. Neither Patent Owner nor Dr. Ducharme dispute this testimony by Dr. Baker. PO Resp. 44–45; Ex. 2001 ¶ 110. We credit Dr. Baker’s testimony on this point because it is based on the disclosure of Nerone and basic scientific principles, i.e., Ohm’s law. Thus, we find that Nerone discloses “the capacitor is configured to smooth the rectified output AC voltage.”

Based on our review of the evidence cited by Petitioner and after considering all of Patent Owner’s contentions, we determine that Petitioner establishes by a preponderance of the evidence that claim 11 is unpatentable over Nerone as modified by Martin for claim 7.

F. Ground 2: Obviousness over Nerone, Martin, and Morgan

Claim 8, which depends from claim 7, recites “further comprising power factor correction circuitry.” Ex. 1001, 27:63–64.

Petitioner contends that “it would have been obvious in view of *Morgan* to configure the *Nerone-Martin* system to implement” power factor correction circuitry. Pet. 32 (citing Ex. 1002 ¶¶ 204–207). Patent Owner does not address Petitioner’s contentions for claim 8 but relies on its contentions for claim 7. PO Resp. 46.

1. Morgan – Exhibit 1033

Morgan is titled “Controlled Lighting Methods and Apparatus.” Ex. 1033, code (54). *Morgan* discloses that “[i]n an ideal situation, both input current and voltage would be in phase and sinusoidal. For a given situation power factor can be defined as real power (Watts) divided by apparent power (Current x Voltage).” Ex. 1033, 76:40–42. *Morgan* further

IPR2022-00149
Patent 10,687,400 B2

discloses that “if the voltage and current are out of phase, then the product [of current and voltage] can be very different from the real power used by a device. For a simple resistive load the power factor is unity or 1.0. For switching supplies, however, the power factor can be much lower.” *Id.* at 76:45–49. Morgan further discloses that “[f]ixing low power factor can be accomplished through the use of power factor correction.” *Id.* at 76:49–51.

2. Analysis

Petitioner contends that “power factor and power factor correction were well understood by a” person of ordinary skill in the art. Pet. 32 (citing Ex. 1002 ¶ 147). Petitioner further contends that “[a] poor power factor would reduce efficiency of a circuit, and certain power supply/driver circuitry could lower a system’s power factor.” *Id.* (citing Ex. 1002 ¶ 148; Ex. 1013, 5:1–12). Petitioner turns to Morgan which, according to Petitioner, “describes power factor correction as a solution.” *Id.* (citing Ex. 1033, 76:49–54). Petitioner further contends that Morgan discloses “a typical LED illumination power and data supply system for a lighting unit” with power factor corrector 4104. *Id.* at 32–33 (citing Ex. 1033, 13:16–17, Fig. 48). Petitioner further contends that power factor correction circuitry “was known to be a publicly and commercially available product.” *Id.* at 33 (citing Ex. 1002 ¶¶ 149–150; Ex. 1013, 1:54–2:67, 3:14–15, 5:53–59; Ex. 1031, 7:5–10; Ex. 1093, 1:6–26). Petitioner further contends that a person of ordinary skill in the art “would have been motivated to modify the combined *Nerone* lighting system to include power factor correction circuitry like that claimed, *e.g.*, for obtaining a high power factor and thereby increasing the efficiency of the lighting system” and would have had

IPR2022-00149
Patent 10,687,400 B2

a reasonable expectation of success. *Id.* at 34–35 (citing Ex. 1002 ¶¶ 152–153).

We have reviewed Petitioner’s contentions and evidence and determine that Petitioner establishes by a preponderance of the evidence that claim 8 would have been unpatentable over the combined teachings of Nerone, Martin, and Morgan.

G. Ground 3: Obviousness over Nerone, Martin, and Zinkler

Claim 10 depends from claim 7 and recites “wherein the rectified output AC voltage provided to the LED circuit array is relatively close to the input AC voltage input received from the mains power source.” Ex. 1001, 28:1–4.

Petitioner contends that “*Nerone-Martin* in view of *Zinkler* discloses or suggests this limitation.” Pet. 35 (citing Ex. 1002 ¶¶ 71–74, 154–163). Patent Owner does not address Petitioner’s contentions for claim 10 but relies on its contentions for claim 7. PO Resp. 47.

1. Zinkler – Exhibit 1042

Zinkler discloses “[a] track lighting hybrid illumination system comprising a power supply circuit having an input for connecting to a voltage source of low frequency for providing an output voltage with altered electrical characteristics.” Ex. 1042, code (57). Zinkler discloses illumination system 40 comprising “rectifier 46 in combination with the variable frequency inverter 48 [that] constitutes a frequency conversion means 50 for converting low frequency voltage produced by the AC voltage source 42 to a high frequency voltage” and an optional step up transformer that “can be used to ensure that the voltage V_{out} across conductors 43 is

IPR2022-00149
Patent 10,687,400 B2

equal to the voltage of the AC source 42 or to any other desired value.” *Id.* at 9:12–15, 9:38–41.

2. Analysis

Petitioner contends that Nerone’s “circuit 400 of figure 4 ‘is identical to the power supply circuit 100 of Fig. 1, with the exception of the resonant load circuit 405.’” Pet. 36 (citing Ex. 1032, 5:52–54). Petitioner further contends that “circuit 400 of *Nerone*’s Figure 4, like circuit 100 of *Nerone*’s Figure 1, discloses ‘[a] DC-to-AC converter, which includes first and second switches 120 and 125.’” *Id.* (citing Ex. 1002 ¶ 156; Ex. 1032, Fig. 1, Fig. 4). Petitioner turns to Zinkler’s step up transformer for disclosure of an output voltage equal to the voltage of the AC source. *Id.* at 38 (citing Ex. 1002 ¶ 158; Ex. 1042, 9:33–41). Petitioner further contends that in light of this disclosure, a person of ordinary skill in the art would have “found it obvious to, configure the driver of the above *Nerone-Martin* system to implement a transformer to adjust the voltage provided by *Nerone*’s DC-AC converter circuitry such that the output of the driver is relatively close to the input AC voltage received from the mains power source” and would have had a reasonable expectation of success. *Id.* a 38–39 (citing Ex. 1002 ¶ 159, 161–62).

We have reviewed Petitioner’s contentions and evidence and determine that Petitioner establishes by a preponderance of the evidence that

IPR2022-00149
 Patent 10,687,400 B2

claim 10 would have been unpatentable over the combined teachings of Nerone, Martin, and Zinkler.

H. Ground 4: Obviousness over Nerone, Martin, and Michael

Claim 12 depends from claim 7 and recites “a data communication circuit comprising an antenna, wherein the data communication circuit is integrated with the substrate.” Ex. 1001, 28:7–10.

Petitioner contends that “it would have been obvious in view of *Michael* and the state of the art to implement” the features recited in claim 12. Pet. 40 (citing Ex. 1002 ¶¶ 75–79, 164–173). Patent Owner disputes Petitioner’s contentions. PO Resp. 47–49.

1. Michael – Exhibit 1008

Michael discloses a lighting assembly including “a remote control assembly for selectively energizing tricolor diodes.” Ex. 1008, code (57). Michael discloses that the 5-volt output of unit 330 powers microcomputer 334 and 24-volt raw DC voltage from unit 324 is brought out to unit 328, which provides 18 volts to power LED drivers 338, 340 and 342. *Id.* at 7:57–64. We reproduce Figure 15 of Michael below:

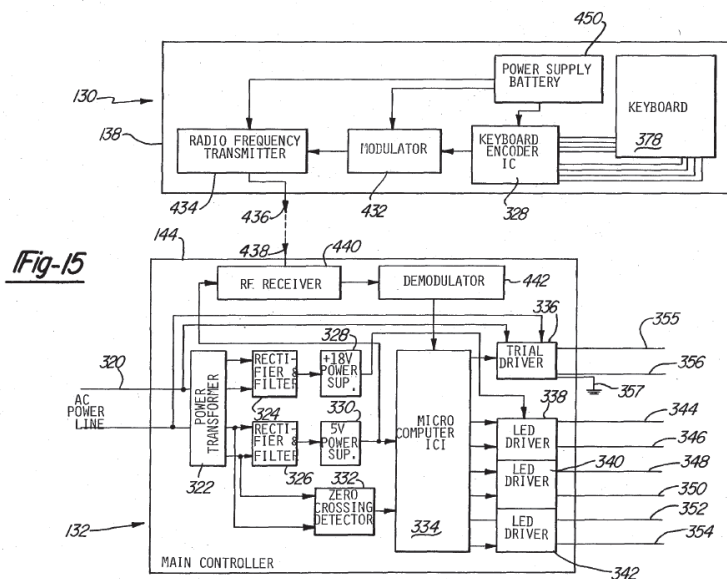

IPR2022-00149
Patent 10,687,400 B2

Figure 15 is a block diagram of a control assembly for use with Michael's lighting assembly. Ex. 1008, 2:48–50.

In Figure 15, transmitter 434 provides a signal through antenna 436 to receiving antenna 438, which in turn inputs the signal to radio frequency receiver 440 that in turn outputs to demodulator 442, which outputs to microcomputer 334. *Id.* at 10:52–58. Michael explains that, as above, unit 328 provides 18 volts to power LED drivers 338, 340 and 342.” *Id.* at 7:59–63.

2. Analysis

Petitioner contends that Michael “discloses a lighting assembly including LED drivers . . . coupled to LEDs . . . via drive/return lines . . . and further discloses an antenna 438 . . . receiving data wirelessly for remote[] control of LEDs.” Pet. 40 (citing Ex. 1002 ¶ 166; Ex. 1008, 8:23–24, 8:29–34, 8:54–66, 8:67–9:2, Fig. 15). Petitioner further contends that “*Michael's* encoder IC 328 provides an encoded signal that is modulated and transmitted to antenna 438, and is inputted to a radio frequency receiver 440 . . . [which] outputs to a demodulator 442 which outputs to microcomputer 334.” *Id.* at 42 (citing Ex. 1002 ¶ 167; Ex. 1008, 10:48–58. According to Petitioner, “*Michael's* controller 132, in conjunction with antenna 438, discloses a data communication circuit comprising an antenna.” *Id.* (citing Ex. 1002 ¶ 168).

Petitioner next contends that a person of ordinary skill in the art “would have been motivated to configure the *Nerone-Michael* system to comprise a data communication circuit that comprises an antenna and that is integrated with the substrate.” Pet. 42 (citing Ex. 1002 ¶ 70). According to Petitioner, “such a configuration would have been useful for enabling remote wireless control of the lighting system” and “wireless remote control of

IPR2022-00149
Patent 10,687,400 B2

lighting was well known.” *Id.* (citing Ex. 1002 ¶ 170; Ex. 1005, ¶¶ 32, 83, 110, 123, 177, Abstract, Fig. 5; Ex. 1008, 10:48–58, Fig. 15; Ex. 1022, Fig. 4A). Petitioner further contends that wireless control of traffic light systems, as in Nerone, was also well known. *Id.* at 43 (citing Ex. 1002 ¶ 171; Ex. 1103, 1:11–62, 3:34–63).

Patent Owner responds that Michael discloses an incandescent bulb fixture with vertical LED ribs 72, 40, and 54 surrounding incandescent bulb 34. PO Resp. 47–48 (citing Ex. 1008, Figs. 1–2; Ex. 2001 ¶ 115). Patent Owner contrasts Michael with Nerone which “is directed to a traffic light assembly.” *Id.* at 48 (citing Ex. 1032, 2:63–65, 5:10–12, 5:23–25, 5:51–52, 6:7–11; Ex. 2001 ¶ 116). Patent Owner contends that a person of ordinary skill in the art “would have no reason to incorporate a remote control to wirelessly control a traffic light. It is well known that traffic lights turn on and off automatically and there is no need for a remote control device to wirelessly change lights from green to yellow, yellow to red, etc.” *Id.* at 49 (citing Ex. 2001 ¶ 117). Patent Owner further contends that a person of ordinary skill in the art would not combine “Martin’s light fixture having an incandescent light surrounded by vertically displaced LED ribs with the traffic light circuit of Nerone” because “Michael’s modified incandescent light fixture is a completely different apparatus with a completely different application compared to Nerone.” *Id.* (citing Ex. 2001 ¶ 118).

Petitioner, in turn, replies that Patent Owner “ignores evidence of wireless lighting control, including traffic lights, and the supported reasons for modifying *Nerone*.” Pet. Reply 21 (citing Pet. 40–43). Petitioner further contends that Patent Owner’s argument that a person of ordinary skill in the art “would not combine ‘Michael’s light fixture . . . with the traffic light

IPR2022-00149
Patent 10,687,400 B2

circuit of Nerone’ . . . is inapposite” because it is based on an improper bodily incorporation of Nerone and Michael. *Id.* at 22.

For the following reasons, Petitioner persuades us that claim 12 would have been unpatentable in light of Nerone, Martin, and Michael.

Patent Owner contends that “there is no reason to incorporate a remote control to wirelessly control a traffic light.” PO Resp. 49 (citing Ex. 2001 ¶ 117). Patent Owner bases this contention on Dr. Ducharme’s testimony which repeats the Petition verbatim and ignores evidence cited in the Petition. Exhibit 1103 discloses that “[a] variety of methods, systems and devices have been proposed to allow emergency vehicles to control traffic signals. These typically use radio transmitter systems for activating emergency preemption controls on the traffic signals.” Ex. 1103, 1:40–44. Consequently, Dr. Ducharme’s testimony on this point is contrary to the disclosure of Exhibit 1103 which discloses that emergency vehicles remotely control traffic lights. His testimony, is entitled to little, if any, weight. Patent Owner’s contention is, thus, unavailing.

Patent Owner’s second contention is likewise unavailing because the Petition does not propose to bodily incorporate Nerone and Michael. Rather, the Petition proposes in light of Martin and the knowledge of one of ordinary skill in the art “to configure the *Nerone-Michael*¹¹ system to comprise a data communication circuit that comprises an antenna and that is incorporated with the substrate.” Pet. 42 (citing Ex. 1002 ¶ 170).

We have reviewed Petitioner’s contentions and the evidence of record and after considering Patent Owner’s contentions, we find that the

¹¹ The reference to “Nerone-Michael” appears to be a typographical error. We assume it should refer to “Nerone-Martin.”

IPR2022-00149
Patent 10,687,400 B2

combination of Nerone, Martin, and Michael suggests the limitations recited in claim 12. Further, Petitioner provides reasons supported by a rational underpinning why a person of ordinary skill in the art would have been motivated to combine Nerone, Martin, and Michael. Ex. 1002 ¶¶ 168–172.

For all the foregoing reasons, we determine that Petitioner establishes by a preponderance of the evidence that claim 12 would have been unpatentable over Nerone, Martin, and Michael.

I. Ground 5: Obviousness over Nerone, Martin, Michael, and Gleener

Claim 13, which depends from claim 12, recites “wherein the capacitor is a first capacitor, wherein the data communication circuit further comprises an inductor and a second capacitor.” Ex. 1001, 28:12–14.

Petitioner contends that “*Nerone-Martin-Michael* in view of *Gleener* discloses or suggests” the limitations of claim 13. Pet. 43–44 (citing Ex. 1002 ¶¶ 80–83, 174–181). Patent Owner does not address Petitioner’s contentions for claim 13 but relies on its contentions for claim 12 and claim 7. PO Resp. 50.

1. Gleener – Exhibit 1039

Gleener describes a tunable dual band antenna system. Ex. 1039, code (57). The system includes a transceiver, a matching network and an antenna. *Id.* The matching network tunes the antenna to the transceiver at both a first and second frequency. *Id.* The matching network has a variable capacitor, an inductor and a second capacitor. *Id.* The value of the variable capacitor is chosen to tune the antenna at the first frequency and the second frequency such that the system can be used to transmit and receive electromagnetic energy over two bandwidths. *Id.* The values of the variable capacitor, the inductor, and the second capacitor are chosen to minimize the

IPR2022-00149
Patent 10,687,400 B2

standing wave ratio of the system at both the first frequency and the second frequency. *Id.*

2. *Analysis*

Petitioner first refers to its contentions for limitation 7(c) and contends that Nerone’s “rectifier 34 includes a capacitor, and that capacitor is a ‘first capacitor’ as claimed.” Pet. 44 (citing Ex. 1002 ¶ 175). Petitioner next contends that “[t]o the extent *Nerone-Martin-Michael* does not explicitly disclose that the data communication circuit discussed for claim 12 . . . comprises an inductor and a second capacitor, it would have been obvious in view of *Gleener* to configure the *Nerone-Martin-Michael* system to implement such features.” *Id.* (citing Ex. 1002 ¶ 175).

Petitioner next contends that *Gleener* discloses “implementing an antenna-based system, including maximizing transfer of energy to the antenna.” Pet. 44 (citing Ex. 1002 ¶ 176; Ex. 1039, code (54), code (57), ¶ 1). Petitioner further contends that “*Gleener* discloses a data communication circuit comprising an inductor and a capacitor.” *Id.* (citing Ex. 1002 ¶ 177; Ex. 1039 ¶ 20, Fig. 3). Petitioner further contends that “*Gleener* discloses that its data communication circuit includes a matching network 104 comprising an inductor 110 . . . and a capacitor 112.” *Id.* at 45 (citing Ex. 1002 ¶ 178; Ex. 1039 ¶ 14, Fig. 3).

Petitioner next contends that, in light of *Gleener*, a person of ordinary skill in the art “would have been motivated to configure the *Nerone-Martin-Michael* data communication circuit to comprise an inductor and a second capacitor.” Pet. 46 (citing Ex. 1002 ¶ 180). According to Petitioner, including “an inductor and a second capacitor to match the impedance between a transmitter/receiver and the *Nerone-Martin-Michael* antenna

IPR2022-00149
Patent 10,687,400 B2

would have promoted efficiency and antenna performance.” *Id.* (citing Ex. 1002 ¶ 180; Ex. 1039 ¶ 2).

We have reviewed Petitioner’s contentions and evidence and determine that Petitioner establishes by a preponderance of the evidence that claim 12 would have been unpatentable over the combined teachings of Nerone, Martin, Michael, and Gleener.

J. Ground 6: Obviousness over Zhang and Martin

Petitioner contends that claims 7, 9–11, and 17 are unpatentable over Zhang and Martin. Pet. 47–58. In support thereof, Petitioner identifies the disclosures in Zhang and Martin alleged to describe the subject matter in these claims. *Id.* Additionally, Petitioner cites to Dr. Baker’s Declaration. Ex. 1002 ¶¶ 84–90, 182–203.

Patent Owner contends that Petitioner fails to establish that Zhang and Martin teach limitations 7(b), 7(d), 7(e), and 7(f). PO Resp. 50–64.

We begin our analysis with a brief overview of Zhang. We then address the parties’ respective contentions with respect to claims 7, 9–11, and 17.

1. Zhang – Ex. 1012

Zhang is titled “Lighting Devices Using LEDS.” Ex. 1012, code (54). Zhang discloses chip-on-board LED exit signs having LED chips on a circuit board and “coat[ing] a layer of high reflection material on the board to collect light.” *Id.* at code (57).

Zhang depicts the design of the circuitry of a circuit board in Fig. 2.1, reproduced below:

IPR2022-00149
 Patent 10,687,400 B2

[e] a driver connected to the bridge rectifier and configured to provide a rectified output AC voltage to the LED circuit array;

Petitioner contends that Zhang’s “regulator 37” corresponds to the recited driver and is “connected to bridge rectifier 35 . . . and configured to provide a rectified output AC voltage to the LED circuit array.” Pet. 51 (citing Ex. 1012 ¶ 37). In support of this contention, Petitioner provides the following annotated version of Zhang’s Figure 2.1 (*id.* at 52):

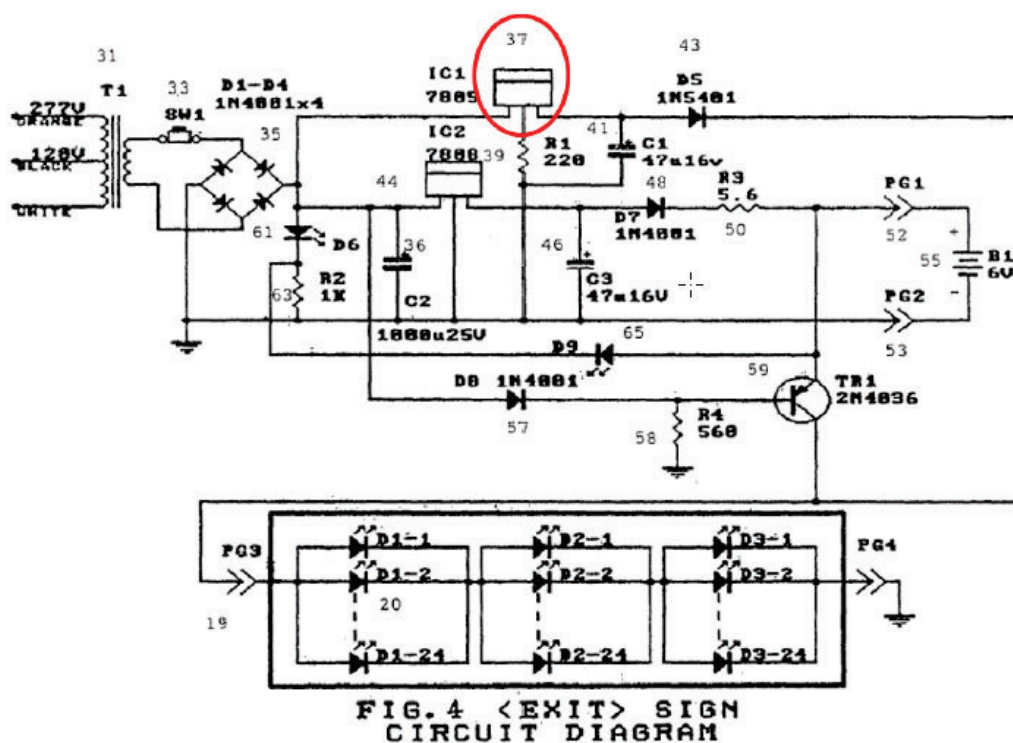

Fig. 2.1, Electronic Circuit Board for LED Exit Sign

Figure 2.1 of Zhang is the electronic circuit diagram of the LED exit sign which Petitioner annotates with a red ellipse around element 37. *Id.* at 52. Petitioner further contends “[t]he voltage provided by regulator 37 to the LEDs is a *rectified* AC voltage because of the rectification performed by

IPR2022-00149
Patent 10,687,400 B2

rectifier 35 and it is an *output* voltage because it is the output of regulator 37.” *Id.* at 51 (citing Ex. 1002 ¶ 189).

Patent Owner contends that a person of ordinary skill in the art “would readily recognize that the part number for regulator 33 (7805) refers to the Fairchild Semiconductor LM 7805 Fixed Voltage Regulator, which provides a fixed output voltage.” PO Resp. 59 (citing Ex. 2001 ¶¶ 1335–136; Ex. 2008, 1; Ex. 2011). Patent Owner further contends that a person of ordinary skill in the art “would understand that the LM 7805 fixed voltage regulator 37 provides a fixed output DC voltage.” *Id.* at 59–60 (citing Ex. 1102, Fig. 2.1; Ex. 2001 ¶ 136). According to Patent Owner, Zhang’s “rectifier 35 produces an output” of 11.3V which “is the input to voltage regulator 37 which has an output of 5V DC.” *Id.* at 60 (citing Ex. 2001 ¶ 138). Patent Owner further contends that this limitation is not satisfied because “the LM 7805 fixed voltage regulator (the alleged ‘driver’) **receives** a ‘rectified AC voltage’, but its does not **provide** a ‘rectified AC voltage.’” *Id.* (citing Ex. 2001 ¶ 138).

Petitioner replies that Patent Owner “seems to imply that a *direct* connection is required between the output of the claimed *bridge rectifier* (providing a rectified AC voltage) and LED circuit array” but “claim 7 recites a *driver* ‘configured to provide a rectified output AC voltage’ that is connected to the bridge rectifier.” Pet. Reply 25 (citing PO Resp. 60; Ex. 1001, 27:54–55). Petitioner contends that Patent Owner’s “argument relies on a distinction between ‘rectified AC voltage’ and ‘DC voltage’ absent in the ’400 patent.” *Id.* (citing Ex. 1001, 2:20–23, 3:38–59, 4:20, 13:46–47). Petitioner further contends that Patent Owner’s “position is at odds with [Dr. Ducharme’s] view that ‘rectified AC’ simply means ‘voltage from a

IPR2022-00149
Patent 10,687,400 B2

rectifier.” *Id.* at 26 (citing Ex. 11:9–12:9). Petitioner further contends that Patent Owner’s assertion “that regulator 37 is a specific regulator is speculation, but, even if it were, PO’s blanket cite to Exhibit 2008 does not show using such a regulator in *Zhang* with a bridge rectifier means it’s output is not a rectified AC voltage.” *Id.* (citing PO Resp. 59; Ex. 2008). Petitioner also contends that Exhibit 2008 indicates the regulator “can be used to obtain ‘variable voltages.’” *Id.*, n. 15.

In the Sur-reply, Patent Owner contends that, in the Patent Owner Response, it “did not address an alleged connection involving the bridge rectifier and the LED circuit array, as Petitioner suggests.” Sur-reply 24 (citing Pet. Reply 25; PO Resp. 59–60). Patent Owner reiterates that “the output of voltage regulator 37 is not a rectified AC voltage output.” *Id.*

For the following reasons, Petitioner does not persuade us that *Zhang* and *Martin* teach or suggest this limitation.

This limitation recites, *inter alia*, “a driver . . . configured to provide a rectified output AC voltage to the LED circuit array.” Ex. 1001, 27:54–56. In this case, Petitioner contends that *Zhang*’s regulator 37 corresponds to the recited driver. Pet. 51. Petitioner points to *Zhang*’s bridge rectifier 35 for generating rectified AC voltage that is provided to regulator 37. *Id.* Patent Owner does not dispute that bridge rectifier 35 provides a rectified AC voltage to regulator 37. *See* PO Resp. 60 (“Specifically, the rectifier 35 produces an output . . . 11.3V.”). Patent Owner’s contentions focus on the effect regulator 37 has on the rectified AC voltage provided to Petitioner’s “driver.” In other words, what does regulator 37 provide to the LED circuit array?

IPR2022-00149
Patent 10,687,400 B2

Petitioner contends that Patent Owner’s argument that regulator 37 is the Fairchild LM 7805 regulator is “speculation.” Pet. Reply 26. Dr. Baker, however, appears to confirm Petitioner’s contention in his deposition. Ex. 2006, 106:14–7.

In his declaration, Dr. Baker does not analyze what effect regulator 37 has on the input received from bridge rectifier 35. Ex. 1002 ¶ 189. Rather, his testimony assumes that the rectified AC voltage passes through regulator 37 unchanged. *Id.*

Dr. Ducharme, on the other hand, testifies that “the rectifier 35 produces an output computed as . . . 11.3 V. That is the input to voltage regulator 37 which has an output of 5 V DC.” Ex. 2001 ¶ 84 (citing Ex. 1012 ¶ 84). Although Petitioner submitted a Reply Declaration from Dr. Baker, Dr. Baker did not address or dispute Dr. Ducharme’s testimony on this point. *See* Ex. 1107 ¶¶ 31–33. Further, Petitioner does not direct us to any portion of Dr. Ducharme’s deposition, nor have we been able to locate any, discussing his testimony.

Dr. Baker testified as follows:

I see that . . . regulator, if memory serves 7805 is a 5-volt regulator. I think if you put a resistor, the resistor labeled R1 or 39 in the figure, to ground, the output voltage actually is . . . little bit higher than 5 volts. I think it – to be precise goes to 5 volts plus R1 time whatever current it’s supplying. So if one were supplying 10 milliamps of current through 1N5401, diode that’s labeled 43, then the output of the regulator would go to 7.2 volts. I think the takeaway is that the only time the 7805 outputs 5 volts is if the that middle pin in the regulator is connected to ground. If it’s connected to a resistor, the output voltage can be a little above 5 volts. But anyway, yes, it’s a 5-volt regulator.

Ex. 2006, 106:18–107:7. From this testimony, we infer that regulator 37 has some effect on the AC rectified voltage from bridge rectifier 35. Yet,

IPR2022-00149
Patent 10,687,400 B2

Petitioner provides no evidence or persuasive technical reasoning disputing Dr. Ducharme’s testimony that the output of regulator 37 is not providing “a rectified output AC voltage” to the LED circuit array despite the admitted differences between the input and output of regulator 37. In the absence of evidence or persuasive technical reasoning, Petitioner does not carry its burden.

Based on the foregoing, we find that Petitioner does not persuade us that Zhang teaches or suggests this limitation.

Because Petitioner does not persuade us that Zhang teaches or suggests this limitation, Petitioner does not establish by a preponderance of the evidence that claim 7 would have been unpatentable over Zhang and Martin.

3. Claims 9–11

Claims 9–11 depend from claim 7. Ex. 1001, 27:65–28:6, 28:30–33. Petitioner details the disclosure in Zhang and Martin that it contends corresponds to the limitations in claims 9–11 and 17. Pet. 56–58.

We have reviewed Petitioner’s contentions as well as the cited evidence and find that it does not cure the deficiencies discussed above for claim 7.

We, thus, determine that Petitioner has not proven by a preponderance of the evidence that claims 9–11 would have been unpatentable over Zhang and Martin.

4. Claim 17

Claim 17 depends from claim 14. Ex. 1001, 28:30. Patent Owner has statutorily disclaimed claim 14. PO Resp. 65 (citing Ex. 2011).

IPR2022-00149
Patent 10,687,400 B2

Petitioner sets forth contentions supported by evidence that Zhang teaches or suggests each limitation of claim 14. Pet. 60–66. In arguing for the patentability of claim 17, Patent Owner does not dispute Petitioner’s contentions for claim 14. PO Resp. 65–66.

We have reviewed Petitioner’s contentions for claim 14 and find that Zhang discloses or suggests each limitation of claim 14.

Claim 17 recites “wherein the LEDs are coated or doped with at least one of phosphor, nano-crystals, or a lighting changing or enhancing substance.” Ex. 1001, 28:30–32.

Petitioner contends that “the application of phosphors and light changing substances to LEDs was a well-known technique in the art, as explained in Ground 1.” Pet. 56 (citing Ex. 1002 ¶¶ 197–200; Ex. 1015 ¶ 27; Ex. 1014, 12:4–13; Ex. 1049, 2:37–45, 3:36–45, 4:34–37, 5:54–58, 8:34–39, Fig. 6). Petitioner further contends that “*Martin* discloses LEDs coated with a wavelength converting layer (*i.e.*, ‘a light changing substance,’ as claimed), such as a phosphor, to enable conversion of the color of light emitted by the LEDs.” *Id.* at 56–57 (citing Ex. 1002 ¶ 198; Ex. 1015 ¶¶ 5, 27; Ex. 1014, 12:4–13). Petitioner further contends a person of ordinary skill in the art “would have been motivated, and found it obvious, to coat the LEDs of . . . modified *Zhang*’s device (claim 14) with a phosphor or other light changing material.” *Id.* at 57 (citing Ex. 1002 ¶ 199). Petitioner further contends that a person of ordinary skill in the art would have had a reasonable expectation of success in doing so. *Id.* (citing Ex. 1002 ¶ 200).

Patent Owner, in turn, contends that a person of ordinary skill in the art would understand that “the LED exit sign that Petitioner relies upon for its unpatentability theory . . . would have LEDs of one color: red.” PO Resp.

IPR2022-00149
Patent 10,687,400 B2

63 (citing Ex. 2001 ¶ 147; Ex. 2006, 108:21–109:6). Patent Owner further contends that “[a]t the time of the invention in 2004, red LEDs were well known in the art” and “[a]ccordingly, a [person of ordinary skill in the art] would implement the LED exit sign of Zhang using red LEDs, and there would be no reason to refer to Martin to coat or dope the LEDs to provide red illumination for the exit sign.” *Id.* at 64 (citing Ex. 2001 ¶ 148; Ex. 2009, 3:35–46; Ex. 2010, 4:60–63).

In the reply, Petitioner contends that Patent Owner “fails to show any significance of red LEDs in undercutting a use of a phosphor to produce colored light” and “does not dispute the well-known use of red and green phosphor coatings to produce colored light.” Pet. Reply 28 (citing Ex. 1015 ¶ 27). Petitioner further contends that Patent Owner’s “submission of known ‘red LEDs’ (Exs. 2009-2010) does not show otherwise—particularly because the exhibits lack any indication that the described ‘red LEDs’ *do not use* [] a phosphor.” *Id.*

For the following reasons, Petitioner persuades us that claim 17 would have been unpatentable over the combined teachings of Zhang and Martin.

In Dr. Baker’s testimony, he relies on Exhibit 1049 for disclosing that phosphor layers may be used to provide specific colored light. Ex. 1002 ¶ 197. Patent Owner points to other references that purportedly show that “red LEDs were well known in the art.” PO Resp. 64. After reviewing the cited portions of Exhibits 2009 and 2010, we agree with Petitioner that there is nothing to indicate the red LEDs do not use a phosphor. Consequently, Patent Owner’s evidence does not undercut Dr. Baker’s testimony, which we credit, as to why a person of ordinary skill in the art would have been motivated with a reasonable expectation of success to modify Zhang in light of Martin

IPR2022-00149
Patent 10,687,400 B2

“with at least one of a phosphor, nano-crystals, or light changing substance.”
Ex. 1002 ¶¶ 199–200.

After review of Petitioner’s contentions and evidence and after considering Patent Owner’s contentions and evidence, we determine that Petitioner establishes by a preponderance of the evidence that claim 17 would have been unpatentable over Zhang and Martin.

K. Ground 7: Obviousness over Zhang, Martin, and Morgan

Claim 8 depends from claim 7. Ex. 1001, 27:63–64. Petitioner details the disclosure in Zhang, Martin, and Morgan that it contends corresponds to the limitations in claim 8 as well as reasons for combining Zhang with Morgan. Pet. 59.

We have reviewed Petitioner’s contentions as well as the cited evidence and find it does not cure the deficiencies discussed above for claim 7 in Ground 6.

We, thus, determine that Petitioner has not established by a preponderance of the evidence that claim 8 would have been unpatentable over Zhang, Martin, and Morgan.

L. Ground 8: Obviousness over Zhang and Mosebrook

Claim 15 depends from claim 14 and recites “further comprising a 3-way switch.” Ex.1001, 28:25–26. Petitioner contends that claim 15 “would have been obvious in view of *Mosebrook* and state of the art to implement [a 3-way switch] in *Zhang*’s device.” Pet. 66 (Ex. 1002 ¶¶ 91–92, 218–221). Patent Owner disputes Petitioner’s contentions. PO Resp. 66–67.

1. Mosebrook – Ex. 1018

Mosebrook discloses “an antenna which is provided on a lighting control device, for example, a light dimmer, and which receives and

IPR2022-00149
Patent 10,687,400 B2

transmits radio frequency signals for controlling a lamp and communicating status of the lamp e.g., on, off and intensity level.” Ex. 1018, 1:17–21. Mosebrook also discloses that “a user can install a so called three-way electrical switch, i.e., an additional light control switch to an existing hardwired single control system by replacing an existing manually operated lighting control device with a lighting control device having a radio frequency receiver incorporated therein.” *Id.* at 2:30–35. Mosebrook explains that such “replacement lighting control device is hardwired into the electrical system in the same way as the conventional device to control the lamp.” *Id.* at 2:35–37.

2. *Analysis*

Petitioner contends that “*Zhang* discloses the use of a switch in LED lighting devices that control signals connected to LEDs.” Pet. 66 (citing Ex. 1012 ¶ 119; Fig. 5.3). Petitioner further contends that “*Mosebrook* explains that it was known that ‘a user can install a so-called **three-way electrical switch**, *i.e.*, an additional light control switch to an existing hardwired single control system” and a person of ordinary skill in the art “would have known that such a three-way switch was a conventional device that was widely used in various lighting systems, *e.g.*, to enable a user to control a lighting system from two places . . . or control the selection of functionality in lighting systems.” *Id.* at 67 (citing Ex. 1002 ¶ 220; Ex. 1018, 2:30–35; Ex. 1028, 2:1–15, 3:66–4:5, Figs. 1, 4; Ex. 1029, 5:30–34, Fig. 1; Ex. 1040 ¶ 18). According to Petitioner, “[s]uch an implementation would have been a mere combination of known components and technologies, according to known methods, to produce predictable results.” *Id.* at 68 (citing Ex. 1002 ¶ 221).

IPR2022-00149
Patent 10,687,400 B2

Patent Owner contends that “the Petition articulates no reason why an LED exit sign would benefit from a 3-way switch” and “do[es] not even attempt to explain how a 3-way switch would work with an LED exit sign, such as what operating mode would correspond to each of the three switch positions.” PO Resp. 66 (citing Ex. 2001 ¶ 155). Patent Owner further contends that “the National Fire Protection Association . . . Safety Code 101 . . . requires that exit signs be illuminated continuously.” *Id.* (citing Ex. 2013, 70) (“NFPA”). Based on this, Patent Owner contends that a person of ordinary skill in the art “would not implement a 3-way switch to control an exit sign because it would be contrary to safety standards.” *Id.* at 67 (citing Ex. 2001 ¶ 156).

Petitioner replies that the Petition provides reasons why an LED exit sign would have benefitted from a 3-way switch, including versatility in controlling the modified system. Pet. Reply 29 (citing Pet. 67–68). Petitioner further contends that NFPA supports obviousness because it “requires a switch to allow testing of the back-up battery” and “describes switching to various operational modes.” *Id.* (citing Ex. 2013, 70). Petitioner further contends that Zhang discloses “a manual test switch to determine if the battery should be replaced.” *Id.* (citing Ex. 1012 ¶83).

In the Sur-reply, Patent Owner contends that a person of ordinary skill in the art “would understand the NFPA as describing exit signs with two operational modes (not three) and thus would not have reason to modify Zhang’s exit sign to add a three-way switch.” Sur-reply 26–27.

For the following reasons, Petitioner persuades us that claim 15 would have been unpatentable over Zhang and Mosebrook.

IPR2022-00149
Patent 10,687,400 B2

Patent Owner initially contends that modifying Zhang to implement a 3-way switch would be contrary to NFPA. PO Resp. 67. In the Sur-reply, Patent Owner does not dispute that both Zhang and NFPA disclose implementing switches in exit signs and apparently abandons its contention that implementing a three-way switch is contrary to NFPA. Sur-reply 26–27. Instead, it argues that because NFPA specifically discloses two operational modes, an ordinary skilled artisan would not have modified Zhang to include a three-way switch. This argument is immaterial because Petitioner’s challenge does not include NFPA.

Petitioner relies on Dr. Baker’s testimony and Mosebrook’s disclosure that a three-way switch can be used “to control a lighting system from two places or control functionality in lighting systems.” Pet. 67; Ex. 1002 ¶ 221. Dr. Baker testifies that implementing Mosebrook’s 3-way switch in Zhang “would have been a mere combination of known components and technologies, according to known methods to produce predictable results.” Ex. 1002 ¶ 221. Other than citing to NFPA, Dr. Ducharme does not dispute Dr. Baker’s testimony which we credit because it is supported by disclosure from Mosebrook and the state of the art. Ex. 2001 ¶¶ 153–157.

We have reviewed Petitioner’s contentions and evidence and after considering Patent Owner’s contentions determine that Petitioner establishes by a preponderance of the evidence that claim 15 would have been unpatentable over Zhang and Mosebrook.

M. Ground 9: Obviousness over Zhang, Michael, and Gleener

Claim 16 depends from claim 14 and recites “a data communication circuit comprising an antenna, an inductor and a capacitor, wherein the data communication circuit is integrated into a single package.” Ex. 1001,

IPR2022-00149
Patent 10,687,400 B2

28:26–29. Petitioner contends that “it would have been obvious in view of *Michael, Gleener*, and the state of the art to implement” the features recited in claim 16 in *Zhang*. Pet. 68 (citing Ex. 1002 ¶¶ 222–228). Patent Owner disputes Petitioner’s contentions. PO Resp. 67–68.

Petitioner contends that Michael “discloses . . . LED-based lighting systems” and “a data communication circuit comprising an antenna.” Pet. 68–69 (citing Ex. 1002 ¶ 223; Ex. 1008, 1:5–7; 7:20–21, 7:35–43, 9:53–55, 10:48–61, Figs. 12, 15). Petitioner further contends that a person of ordinary skill in the art “would have been motivated to configure *Zhang*’s lighting device to include a data communication circuit comprising an antenna” because such a configuration would have been “useful for enabling a remote wireless control of the lighting device, *e.g.*, to turn on/off or otherwise control lighting (*e.g.*, brightness of lighting).” *Id.* at 69 (citing Ex. 1002 ¶ 224).

Petitioner further contends that a person of ordinary skill in the art would have considered Gleener which discloses “implementing an antenna-based system, including maximizing transfer of energy to the antenna” and “implementing efficient wireless control of the *Zhang-Michael* lighting device.” *Id.* (citing Ex. 1002 ¶ 225; Ex. 1039, code (54), Code (57), ¶ 1). Petitioner next argues that Gleener “discloses a data communication circuit comprising an inductor and a capacitor for impedance matching and describes benefits associated with such impedance matching.” *Id.* at 69–70 (citing Ex. 1002 ¶ 225; Ex. 1039 ¶¶ 2, 4, 14, 20, Figs. 1, 3).

Petitioner next contends that a person of ordinary skill in the art “would have been motivated to configure the data communication circuit of the *Zhang-Michael* device to comprise an inductor and a capacitor, in

IPR2022-00149
Patent 10,687,400 B2

addition to the antenna” to “advantageously promote[] efficiency and high antenna performance.” Pet. 70 (citing Ex. 1002 ¶ 226; Ex. 1039 ¶ 2).

Patent Owner contends that “Petitioner does not articulate a reason why a [person of ordinary skill in the art] would incorporate a remote control/transceiver to wirelessly control an LED exit sign.” PO Resp. 68. According to Patent Owner, “Petitioner only supplies generic reasoning that is untethered to the cornerstone of its theory—the LED exit sign of Zhang.” *Id.* (citing Pet. 69; Ex. 2001 ¶ 161). Patent Owner next contends that a person of ordinary skill in the art “would not have a reason to combine teachings from Michael’s light fixture having an incandescent light surrounded by vertically displaced LED ribs with the LED exit sign of Zhang. Michael’s . . . light fixture is a completely different apparatus with a completely different application than Zhang.” *Id.* (citing Ex. 2001 ¶ 162).

For the following reasons, Petitioner persuades us that claim 16 would have been unpatentable over Zhang, Michael, and Gleener.

Patent Owner does not dispute that Michael discloses a data communication circuit comprising an antenna nor does Patent Owner dispute that Gleener discloses a data communication circuit comprising an inductor and capacitor for impedance matching. *See* PO Resp. 67–68. Nor does Patent Owner dispute that Gleener describes benefits associated with impedance matching. *See id.*

Petitioner states reasons why a person of ordinary skill in the art would have been motivated to combine Zhang and Michael, i.e., to enable remote control to turn on or off the Zhang’s lighting device or control the brightness. Pet. 69. Petitioner supports this contention with the testimony

IPR2022-00149
Patent 10,687,400 B2

of Dr. Baker who relies on the disclosure of Zhang and Michael as well as the state of the art. Ex. 1002 ¶¶ 223–224.

Petitioner also states reasons why a person of ordinary skill in the art would have been motivated to further modify Zhang and Michael with Gleener, i.e., for the benefits of impedance matching. Pet. 69–70. Petitioner supports this contention with the testimony of Dr. Baker who relies on the disclosure of Zhang, Michael, and Gleener as well as the state of the art. Ex. 1002 ¶¶ 225–226.

Dr. Ducharme doesn't dispute Dr. Baker's testimony for claim 16. Ex. 2001 ¶¶ 158–163. We credit Dr. Baker's testimony which is supported by evidence for the reasons why a person of ordinary would have combined the teachings of Zhang, Michael, and Gleener. Consequently, Patent Owner's contention that Petitioner merely states generic reasons for the combination is unavailing.

Patent Owner's second contention that a person of ordinary skill in the art would not have combined Zhang and Michael because Michael is a completely different apparatus than Zhang is unavailing because the contention is based on bodily incorporating Zhang and Michael.

We have reviewed Petitioner's contentions and evidence, and after considering Patent Owner's contentions, determine that Petitioner establishes by a preponderance of the evidence that claim 16 would have been unpatentable over Zhang, Michael, and Gleener.

IPR2022-00149
Patent 10,687,400 B2

III. CONCLUSION

Weighing the evidence and the competing testimony, we determine that Petitioner establishes by a preponderance that claims 7–13 and 15–17 of the '400 patent are unpatentable.¹²

In summary:

Claim(s)	35 U.S.C. §	Reference(s)/Basis	Claims Shown Unpatentable	Claims Not Shown Unpatentable
7, 9, 11	103	Nerone, Martin	7, 9, 11	
8	103	Nerone, Martin, Morgan	8	
10	103	Nerone, Martin, Zinkler	10	
12	103	Nerone, Martin, Michael	12	
13	103	Nerone, Martin, Michael, Gleener	13	
7, 9–11, 17	103	Zhang, Martin	17	7, 9–11
8	103	Zhang, Martin, Morgan		8
15	103	Zhang Mosebrook	15	
16	103	Zhang, Michael, Gleener	16	
Overall Outcome			7–13, 15–17	

¹² Should Patent Owner wish to pursue amendment of the challenged claims in a reissue or reexamination proceeding subsequent to the issuance of this decision, we draw Patent Owner's attention to the April 2019 *Notice Regarding Options for Amendments by Patent Owner Through Reissue or Reexamination During a Pending AIA Trial Proceeding*. See 84 Fed. Reg. 16,654 (Apr. 22, 2019). If Patent Owner chooses to file a reissue application or a request for reexamination of the challenged patent, we remind Patent Owner of its continuing obligation to notify the Board of any such related matters in updated mandatory notices. See 37 C.F.R. § 42.8(a)(3), (b)(2).

IPR2022-00149
Patent 10,687,400 B2

IV. ORDER

In consideration of the foregoing, it is hereby:

ORDERED that claims 7–13 and 15–17 of the '400 patent have been shown to be unpatentable by a preponderance of the evidence; and

FURTHER ORDERED that any party seeking judicial review must comply with the notice and service requirements of 37 C.F.R. § 90.2.

IPR2022-00149
Patent 10,687,400 B2

FOR PETITIONER:

Naveen Modi
Joseph Palys
Mark Consilvio
PAUL HASTINGS
naveenmodi@paulhastings.com
josephpalys@paulhastings.com
markconsilvio@paulhastings.com

FOR PATENT OWNER:

Stephen T. Schreiner
James T. Carmichael
Stephen McBride
Minghui Yang
CARMICHAEL IP, PLLC
schreiner@carmichaelip.com
jim@carmichaelip.com
stevemcbride@carmichaelip.com
mitch@carmichaelip.com

Jason A. Engel
Katherine L. Allor
Dennis J. Majewski
K&L GATES LLP
jason.engel.ptab@klgates.com
katy.allor@klgates.com
dennis.majewski@klgates.com

Case: 23-2346 Document: 10 Page: 2 Filed: 10/10/2023

CERTIFICATE OF SERVICE

The undersigned hereby certifies that a true and correct copy of the foregoing has been served on Appellant and Appellee this 10th day of October, 2023, as follows:

James T. Carmichael
Stephen T. Schreiner
Stephen P. McBride
Minghui Yang
CARMICHAEL IP, PLLC
jim@carmichaelip.com
schreiner@carmichaelip.com
stevemcbride@carmichaelip.com
mitch@carmichaelip.com

Naveen Modi
Joseph E. Palys
Mark Consilvio
PAUL HASTINGS LLP
naveenmodi@paulhastings.com
josephpalys@paulhastings.com
markconsilvio@paulhastings.com

/s/ Natasha M. Brotten
Natasha M. Brotten
Paralegal Specialist



US010687400B2

(12) **United States Patent**
Miskin et al.

(10) **Patent No.:** **US 10,687,400 B2**
(45) **Date of Patent:** **Jun. 16, 2020**

(54) **AC LIGHT EMITTING DIODE AND AC LED DRIVE METHODS AND APPARATUS**

(71) Applicant: **Lynk Labs, Inc.**, Elgin, IL (US)

(72) Inventors: **Michael Miskin**, Sleepy Hollow, IL (US); **James N. Andersen**, Elmwood Park, IL (US); **Robert L. Kottritsch**, Shefford (GB)

(73) Assignee: **Lynk Labs, Inc.**, Elgin, IL (US)

(*) Notice: Subject to any disclaimer, the term of this patent is extended or adjusted under 35 U.S.C. 154(b) by 0 days.

(21) Appl. No.: **16/693,081**

(22) Filed: **Nov. 22, 2019**

(65) **Prior Publication Data**

US 2020/0120778 A1 Apr. 16, 2020

Related U.S. Application Data

(60) Continuation of application No. 16/449,273, filed on Jun. 21, 2019, which is a continuation of application No. 16/443,759, filed on Jun. 17, 2019, which is a continuation of application No. 16/407,076, filed on May 8, 2019, now Pat. No. 10,492,252, which is a continuation of application No. 16/148,945, filed on (Continued)

(51) **Int. Cl.**

H05B 37/02 (2006.01)
H05B 45/37 (2020.01)
H05B 45/10 (2020.01)
H05B 45/40 (2020.01)
H05B 45/50 (2020.01)

(52) **U.S. Cl.**

CPC **H05B 45/37** (2020.01); **H05B 45/10** (2020.01); **H05B 45/40** (2020.01); **H05B 45/50** (2020.01)

(58) **Field of Classification Search**

CPC . H02J 3/14; H02M 2001/0006; H04W 84/12; H05B 39/086; H05B 39/088; H05B 47/105; H05B 47/19; H01H 35/146; H01H 9/168; H01Q 1/3291; H01Q 1/2241; H01Q 1/3233; H01Q 1/325; H01Q 1/22

See application file for complete search history.

(56) **References Cited**

U.S. PATENT DOCUMENTS

3,869,641 A 3/1975 Goldberg
4,218,627 A 8/1980 Kiesel
(Continued)

FOREIGN PATENT DOCUMENTS

DE 44 42 677 11/1994
DE 19500694 8/1996
(Continued)

OTHER PUBLICATIONS

U.S. Appl. No. 15/797,806, filed Oct. 30, 2017, inventors: Michael Miskin and James N. Andersen, 59 pages.

(Continued)

Primary Examiner — Monica C King

(74) *Attorney, Agent, or Firm* — Haynes and Boone, LLP

(57) **ABSTRACT**

An LED device for use with an AC voltage power source configured such that at least one LED emits light during a positive phase of power provided from an AC power supply and at least one LED emits light during the negative phase of power provided from an AC power supply. The LED device includes a first power connection lead and a second power connection lead, both leads capable of being connected to and receiving power from an AC power supply.

26 Claims, 48 Drawing Sheets

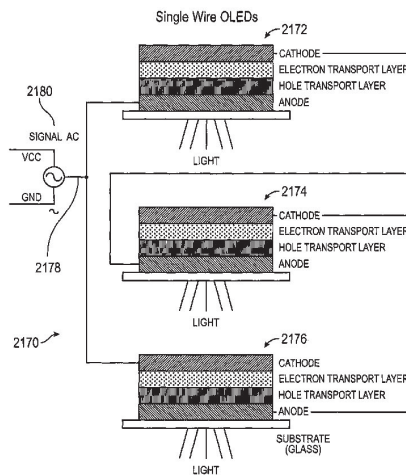

US 10,687,400 B2

Page 2

Related U.S. Application Data

- Oct. 1, 2018, now Pat. No. 10,492,251, which is a continuation of application No. 15/334,029, filed on Oct. 25, 2016, now Pat. No. 10,091,842, which is a continuation-in-part of application No. 14/948,635, filed on Nov. 23, 2015, now Pat. No. 9,615,420, which is a division of application No. 13/697,646, filed as application No. PCT/US2011/036359 on May 12, 2011, now Pat. No. 9,198,237, which is a continuation-in-part of application No. PCT/US2010/062235, filed on Dec. 28, 2010, which is a continuation-in-part of application No. 12/287,267, filed on Oct. 6, 2008, now Pat. No. 8,179,055, and a continuation-in-part of application No. 12/364,890, filed on Feb. 3, 2009, now Pat. No. 8,148,905, which is a continuation of application No. 11/066,414, filed on Feb. 25, 2005, now Pat. No. 7,489,086, said application No. PCT/US2010/062235 is a continuation-in-part of application No. PCT/US2010/001597, filed on May 28, 2010, which is a continuation-in-part of application No. 12/287,267, filed on Oct. 6, 2008, now Pat. No. 8,179,055, said application No. PCT/US2010/062235 is a continuation-in-part of application No. PCT/US2010/001269, filed on Apr. 30, 2010, which is a continuation-in-part of application No. 12/287,267, filed on Oct. 6, 2008, now Pat. No. 8,179,055.
- (60) Provisional application No. 61/333,963, filed on May 12, 2010, provisional application No. 61/284,927, filed on Dec. 28, 2009, provisional application No. 61/335,069, filed on Dec. 31, 2009, provisional application No. 60/997,771, filed on Oct. 6, 2007, provisional application No. 60/547,653, filed on Feb. 25, 2004, provisional application No. 60/559,867, filed on Apr. 6, 2004, provisional application No. 61/217,215, filed on May 28, 2009, provisional application No. 61/215,144, filed on May 1, 2009.

(56) References Cited

U.S. PATENT DOCUMENTS

- | | | | | | | | |
|-----------|----|---------|--------------------|--------------|----|---------|--------------------|
| 4,271,408 | A | 6/1981 | Teshima et al. | 6,380,693 | B1 | 4/2002 | Kastl |
| 4,298,869 | A | 11/1981 | Okuno | 6,412,971 | B1 | 7/2002 | Wojnarowski et al. |
| 4,380,721 | A | 4/1983 | Bullock et al. | 6,430,064 | B1 | 8/2002 | Tsuchimoto et al. |
| 4,506,318 | A | 3/1985 | Nilssen | 6,541,919 | B1 | 4/2003 | Roach et al. |
| 4,535,203 | A | 8/1985 | Jenkins et al. | 6,577,072 | B2 | 6/2003 | Saito et al. |
| 4,751,398 | A | 6/1988 | Ertz, III | 6,580,228 | B1 | 6/2003 | Chen et al. |
| 5,180,952 | A | 1/1993 | Nilssen | 6,614,103 | B1 | 9/2003 | Durocher et al. |
| 5,309,062 | A | 5/1994 | Perkins et al. | 6,697,130 | B2 | 2/2004 | Weindorf et al. |
| 5,442,258 | A | 8/1995 | Shibata | 6,762,562 | B2 | 7/2004 | Leong |
| 5,559,681 | A | 9/1996 | Duarte | 6,781,570 | B1 | 8/2004 | Arrigo et al. |
| 5,575,459 | A | 11/1996 | Anderson | 6,936,968 | B2 | 8/2005 | Cross et al. |
| 5,600,225 | A | 2/1997 | Goto | 6,949,772 | B2 | 9/2005 | Shimizu et al. |
| 5,621,913 | A | 4/1997 | Tuttle et al. | 6,961,190 | B1 | 11/2005 | Tamaoki et al. |
| 5,640,061 | A | 6/1997 | Bornhorst et al. | 7,019,662 | B2 | 3/2006 | Shackle |
| 5,675,485 | A | 10/1997 | Seong | 7,038,400 | B2 | 5/2006 | Rimmer et al. |
| 5,699,218 | A | 12/1997 | Kadah | 7,053,560 | B1 | 5/2006 | Ng |
| 5,739,639 | A | 4/1998 | Johnson | 7,061,188 | B1 | 6/2006 | Katyl et al. |
| 5,790,013 | A | 8/1998 | Hauck | 7,067,992 | B2 | 6/2006 | Leong et al. |
| 5,821,699 | A | 10/1998 | Moisin | 7,144,131 | B2 | 12/2006 | Rains |
| 5,963,012 | A | 10/1999 | Garcia et al. | 7,204,607 | B2 | 4/2007 | Yano et al. |
| 6,040,663 | A | 3/2000 | Bucks et al. | 7,218,527 | B1 | 5/2007 | Jacosen |
| 6,107,744 | A | 8/2000 | Bavaro et al. | 7,288,902 | B1 | 10/2007 | Melanson |
| 6,113,248 | A | 9/2000 | Mistopoulos et al. | 7,350,936 | B2 | 4/2008 | Ducharme et al. |
| 6,118,426 | A | 9/2000 | Albert et al. | 7,365,718 | B2 | 4/2008 | Tsuchida et al. |
| 6,127,799 | A | 10/2000 | Krishnan | 7,489,086 | B2 | 2/2009 | Miskin et al. |
| 6,157,551 | A | 12/2000 | Barak et al. | 7,521,872 | B2 | 4/2009 | Bruning |
| 6,183,104 | B1 | 2/2001 | Ferrara | 7,646,029 | B2 | 1/2010 | Mueller et al. |
| 6,362,789 | B1 | 3/2002 | Trumbull et al. | 7,808,189 | B2 | 10/2010 | Hollnberger et al. |
| | | | | 7,859,196 | B2 | 12/2010 | Lee et al. |
| | | | | 7,936,132 | B2 | 5/2011 | Quek et al. |
| | | | | 8,033,686 | B2 | 10/2011 | Recker et al. |
| | | | | 8,148,905 | B2 | 4/2012 | Miskin et al. |
| | | | | 8,179,055 | B2 | 5/2012 | Miskin et al. |
| | | | | 8,237,581 | B2 | 8/2012 | Ries, II |
| | | | | 8,531,118 | B2 | 9/2013 | Miskin et al. |
| | | | | 8,613,997 | B2 | 12/2013 | Day |
| | | | | 8,648,539 | B2 | 2/2014 | Miskin et al. |
| | | | | 8,841,855 | B2 | 9/2014 | Miskin |
| | | | | 9,198,237 | B2 | 11/2015 | Miskin et al. |
| | | | | 9,247,597 | B2 | 1/2016 | Miskin et al. |
| | | | | 9,249,953 | B2 | 2/2016 | Miskin |
| | | | | 9,516,716 | B2 | 12/2016 | Miskin et al. |
| | | | | 9,615,420 | B2 | 4/2017 | Miskin |
| | | | | 9,693,405 | B2 | 6/2017 | Miskin |
| | | | | 9,750,098 | B2 | 8/2017 | Miskin et al. |
| | | | | 9,807,827 | B2 | 10/2017 | Miskin et al. |
| | | | | 1,015,455 | A1 | 12/2018 | Miskin et al. |
| | | | | 2002/0008973 | A1 | 1/2002 | Boys et al. |
| | | | | 2002/0030455 | A1 | 3/2002 | Ghanem |
| | | | | 2002/0047646 | A1 | 4/2002 | Lys et al. |
| | | | | 2002/0060526 | A1 | 5/2002 | Timmermans et al. |
| | | | | 2002/0089305 | A1 | 7/2002 | Park et al. |
| | | | | 2002/0090983 | A1 | 7/2002 | Chen |
| | | | | 2002/0113246 | A1 | 8/2002 | Nagai et al. |
| | | | | 2002/0114155 | A1 | 8/2002 | Katogi et al. |
| | | | | 2002/0180344 | A1 | 12/2002 | Lichtfuss |
| | | | | 2002/0181208 | A1 | 12/2002 | Credelle et al. |
| | | | | 2002/0190689 | A1 | 12/2002 | Nakamura et al. |
| | | | | 2003/0001657 | A1 | 1/2003 | Worley, Sr. et al. |
| | | | | 2003/0043611 | A1 | 3/2003 | Bockle et al. |
| | | | | 2003/0057886 | A1 | 3/2003 | Lys et al. |
| | | | | 2003/0071259 | A1 | 4/2003 | Yoshida |
| | | | | 2003/0109286 | A1 | 6/2003 | Hack et al. |
| | | | | 2003/0122502 | A1 | 7/2003 | Clauberg et al. |
| | | | | 2003/0169014 | A1 | 9/2003 | Kadah |
| | | | | 2003/0173408 | A1 | 9/2003 | Mosher, Jr. et al. |
| | | | | 2003/0175004 | A1 | 9/2003 | Garito et al. |
| | | | | 2003/0179585 | A1 | 9/2003 | Lefebvre |
| | | | | 2004/0041800 | A1 | 3/2004 | Daniels |
| | | | | 2004/0070520 | A1 | 4/2004 | Sharp et al. |
| | | | | 2004/0079953 | A1 | 4/2004 | Mednik et al. |
| | | | | 2004/0080941 | A1 | 4/2004 | Jiang et al. |
| | | | | 2004/0105264 | A1 | 6/2004 | Spero |
| | | | | 2004/0140771 | A1 | 7/2004 | Kim et al. |
| | | | | 2004/0183380 | A1 | 9/2004 | Otake |
| | | | | 2004/0189218 | A1 | 9/2004 | Leong et al. |
| | | | | 2004/0196636 | A1 | 10/2004 | Kim |
| | | | | 2004/0201988 | A1 | 10/2004 | Allen |
| | | | | 2004/0206970 | A1 | 10/2004 | Martin |

US 10,687,400 B2

Page 3

(56)	References Cited			EP	1 215 944	6/2002
	U.S. PATENT DOCUMENTS			EP	1 331 666	7/2003
				JP	07283848	10/1995
				JP	08-137429	5/1996
2004/0256467	A1	12/2004	Clemens et al.	JP	10111333	4/1998
2005/0040773	A1	2/2005	Lebens et al.	JP	3049746	6/1998
2005/0110426	A1	5/2005	Shao	JP	3057488	8/1998
2005/0122062	A1	6/2005	Hsu	JP	3053498	10/1998
2005/0151511	A1	7/2005	Chary	JP	11-016683	1/1999
2005/0162096	A1	7/2005	Bertrand	JP	10164659	3/1999
2005/0168156	A1	8/2005	Li et al.	JP	3067620	9/1999
2005/0173990	A1	8/2005	Anderson et al.	JP	11-330561	11/1999
2005/0218838	A1	10/2005	Lys	JP	3064160	12/1999
2005/0230600	A1	10/2005	Olson et al.	JP	3068444	5/2000
2006/0038542	A1	2/2006	Park et al.	JP	2000174857	6/2000
2006/0087843	A1	4/2006	Setomoto et al.	JP	2000260212	9/2000
2006/0103913	A1	5/2006	Handschy et al.	JP	2003132708	5/2003
2006/0138971	A1	6/2006	Uang et al.	JP	2004039415	2/2004
2006/0158130	A1	7/2006	Furukawa	WO	WO 88/05213	7/1988
2007/0069663	A1	3/2007	Burdalski et al.	WO	WO 96/02970	2/1996
2007/0228999	A1	10/2007	Kit	WO	WO 99/14705	3/1999
2007/0273299	A1	11/2007	Miskin et al.	WO	WO 99/20085	4/1999
2008/0116816	A1	5/2008	Neuman et al.	WO	WO 02/31406	4/2002
2008/0136347	A1	6/2008	Lin et al.	WO	WO 02/093542	11/2002
2008/0158915	A1	7/2008	Williams	WO	WO 03/027970	4/2003
2008/0198613	A1	8/2008	Cruickshank	WO	WO 03/103157	12/2003
2008/0203405	A1	8/2008	Rooymans	WO	WO 2005048658	5/2005
2008/0203936	A1	8/2008	Mariyama et al.	WO	WO 2008124701	10/2008
2008/0211421	A1	9/2008	Lee et al.	WO	WO 2010/106375	9/2010
2008/0218098	A1	9/2008	Lee et al.	WO	WO 2016164928	10/2016
2009/0221185	A1	1/2009	Ng			
2009/0295300	A1	12/2009	King			
2010/0039794	A1	2/2010	Ghanem et al.			
2010/0163890	A1	7/2010	Miskin			
2010/0207536	A1	8/2010	Burdalski et al.			
2011/0210670	A1	9/2011	Sauerlander et al.			
2011/0234114	A1	9/2011	Miskin et al.			
2012/0043897	A1	2/2012	Miskin et al.			
2012/0206050	A1	8/2012	Spero			
2012/0268008	A1	10/2012	Miskin et al.			
2012/0293083	A1	11/2012	Miskin et al.			
2014/0239809	A1	8/2014	Miskin			
2014/0301073	A1	10/2014	Miskin			
2014/0301074	A1	10/2014	Miskin			
2016/0095180	A1	3/2016	Miskin			
2017/0105256	A1	4/2017	Miskin			
2017/0188426	A1	6/2017	Miskin et al.			
2017/0208656	A1	7/2017	Miskin et al.			
2017/0273154	A1	9/2017	Miskin			
2017/0295616	A1	10/2017	Miskin			
2017/0354005	A1	12/2017	Miskin et al.			
	FOREIGN PATENT DOCUMENTS					
DE	100 32 864		1/2002			
EP	0 243 411		6/1992			
EP	0 770 896		5/1997			
EP	0 798 650		10/1997			
EP	0 837 406		4/1998			
EP	0 940 903		9/1999			
EP	1 050 793		11/2000			
EP	1 191 608		3/2002			
				OTHER PUBLICATIONS		
				Master Thesis of Srinivasa M. Baddela titled "High Frequency AC Operation of LEDs to Resolve the Current Sharing Problem When Connected in Parallel".		
				Srinivasa M. Baddela and Donald S. Zinger, "Parallel Connected LEDs Operated at High Frequency to Improve Current Sharing," IAS 2004, pp. 1677-1681.		
				M. Rico-Secades, et al., "Driver for high efficiency LED based on flyback stage with current mode control for emergency lighting system," Industry Applications Conference, Oct. 2004, pp. 1655-1659.		
				Patent Owners Preliminary Response under 37 CFR 42.107 for Case IPR2016-01116 for Inter Partes Review of U.S. Pat. No. 8,531,118, 66 pages.		
				Lynk Labs, Inc.'s Initial Response to Invalidation Contentions, Northern District of Illinois Civil Action No. 15-cv-04833, 88 pages.		
				Decision on Institution of Inter Partes Review under 37 CFR 42.108 for U.S. Pat. No. 8,531,118, 47 pages.		
				Written Opinion and International Search Report for International App. No. PCT/US2005/006146, 12 pages.		
				Robert W. Erickson & Dragen Maksimovic, "Fundamentals of Power Electronics" (Kluwer Academic Publishers, 2 nd ed.), p. 576.		
				Office Action, U.S. Appl. No. 16/460,790, dated Aug. 5, 2019, 17 pages.		
				Office Action, U.S. Appl. No. 16/460,790, dated Sep. 26, 2019, 22 pages.		
				Office Action received in U.S. Appl. No. 16/443,759, dated Aug. 8, 2019, 7 pages.		

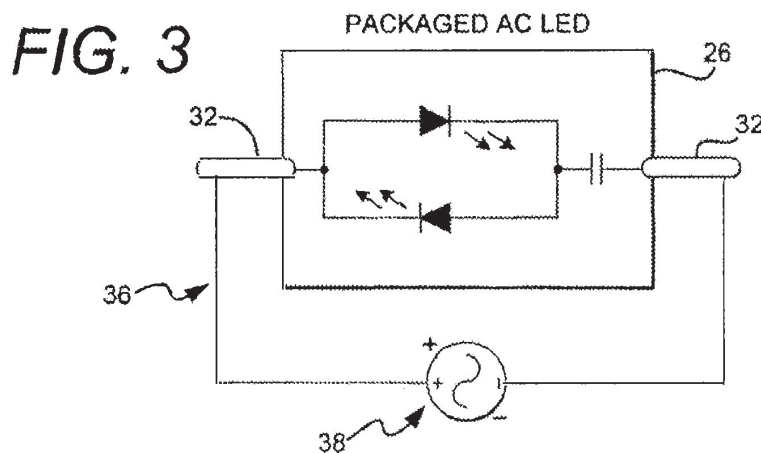
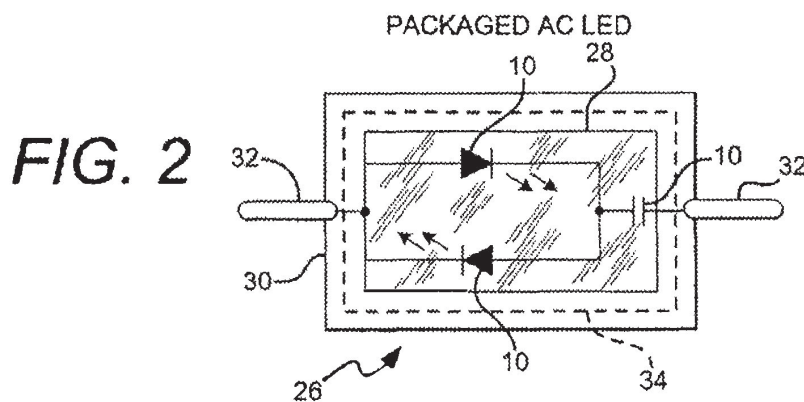
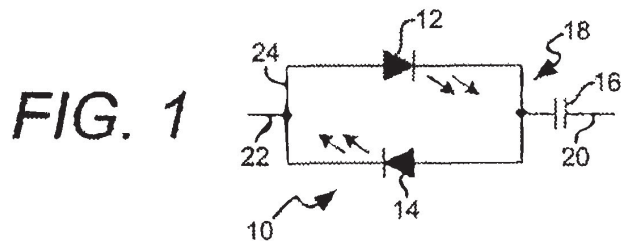

FIG. 4

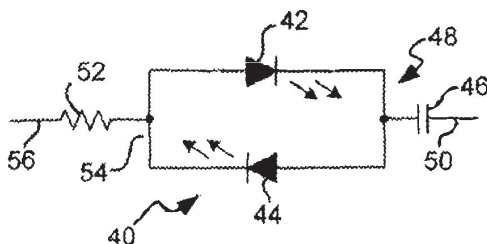

FIG. 5

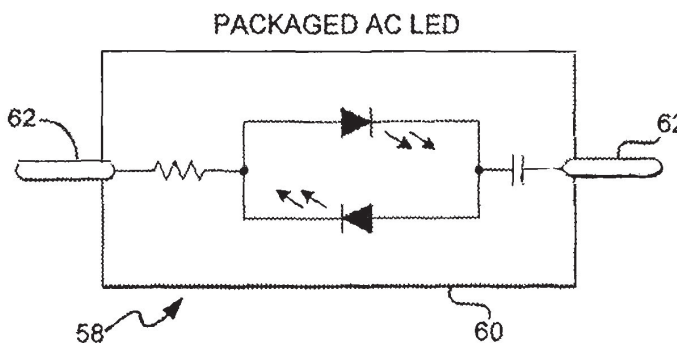

FIG. 6

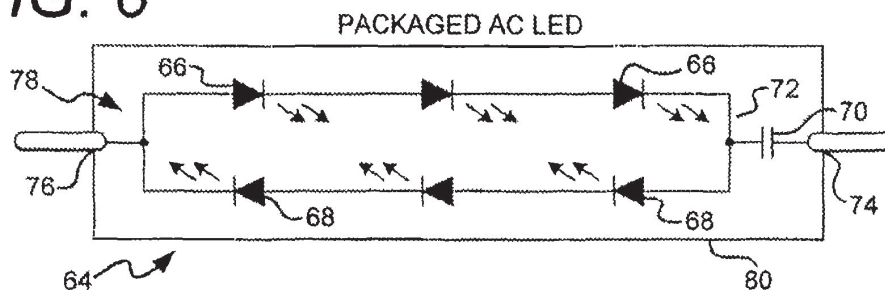

FIG. 7

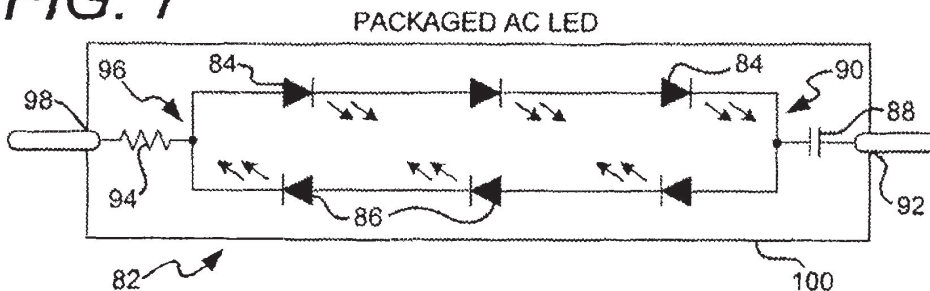

FIG. 8

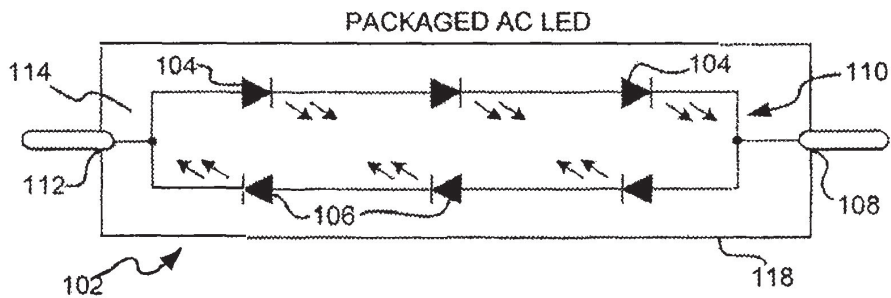

FIG. 9

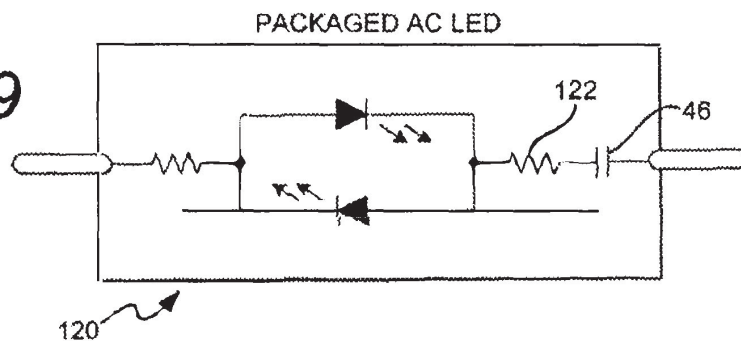
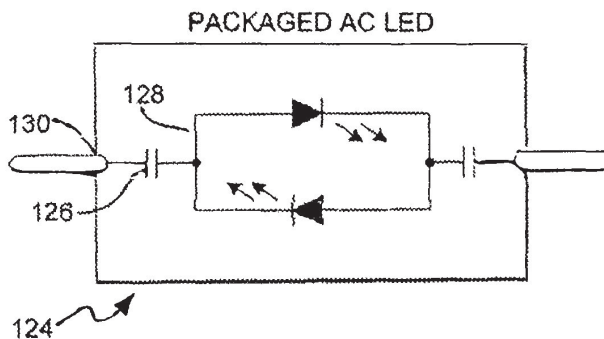

FIG. 10



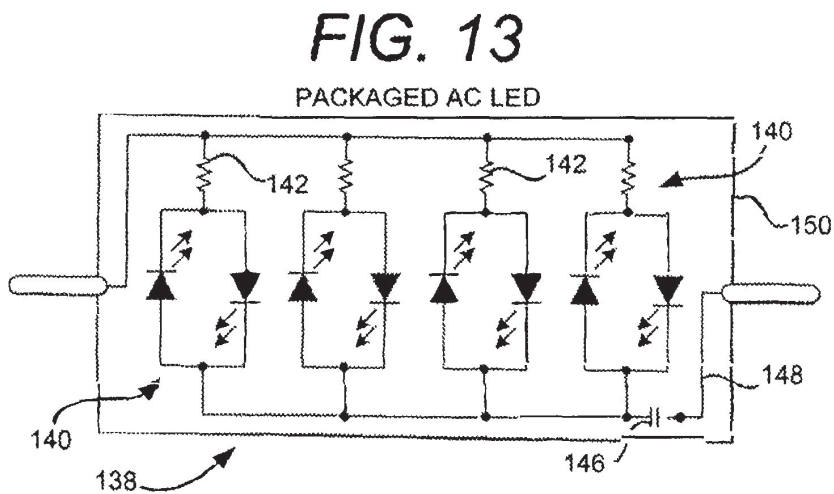
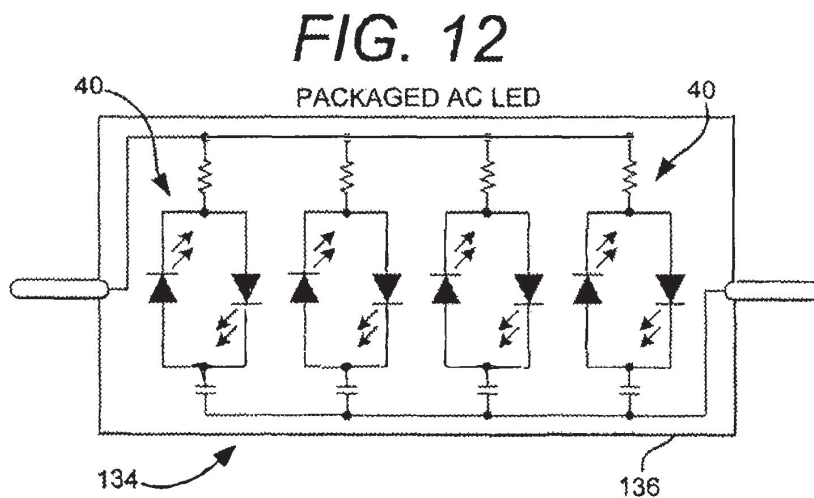
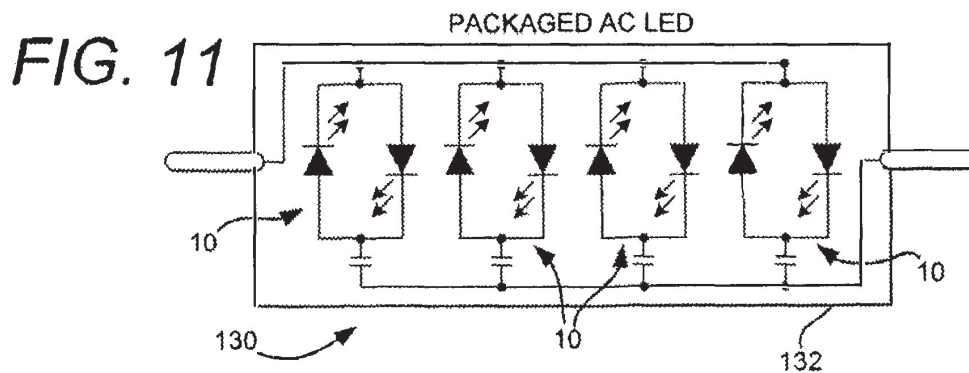

FIG. 14

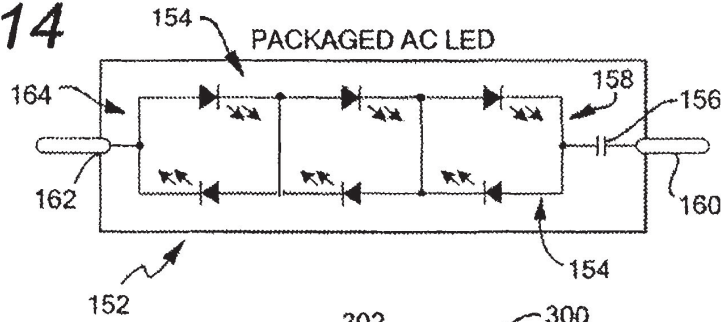

FIG. 15

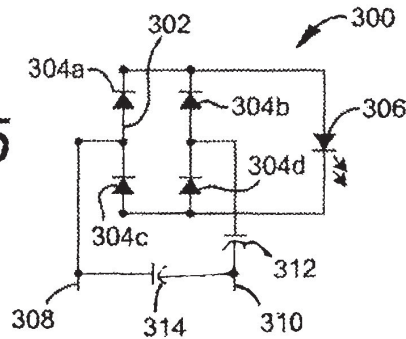

FIG. 16

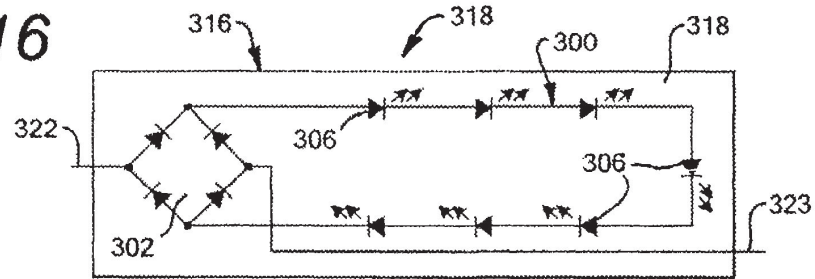
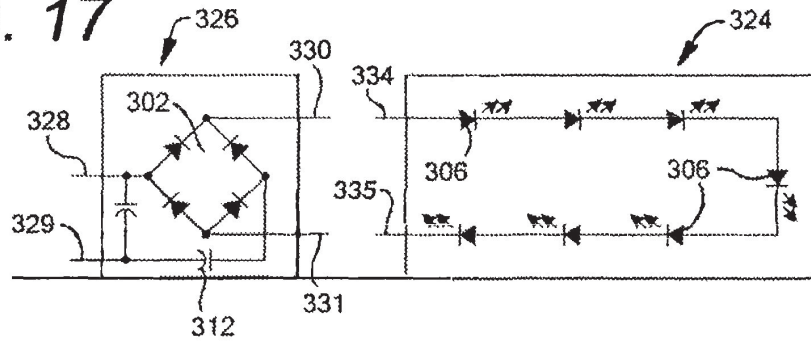

FIG. 17



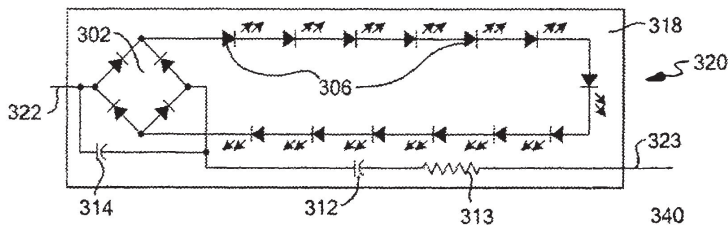

FIG. 18

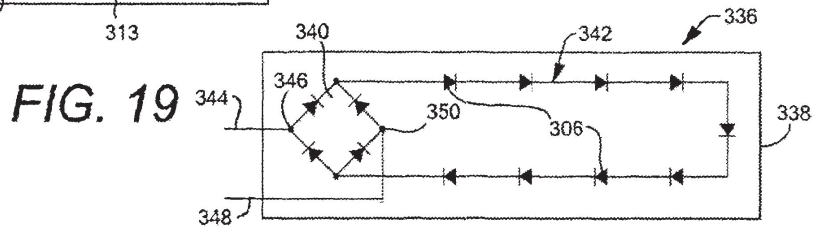

FIG. 19

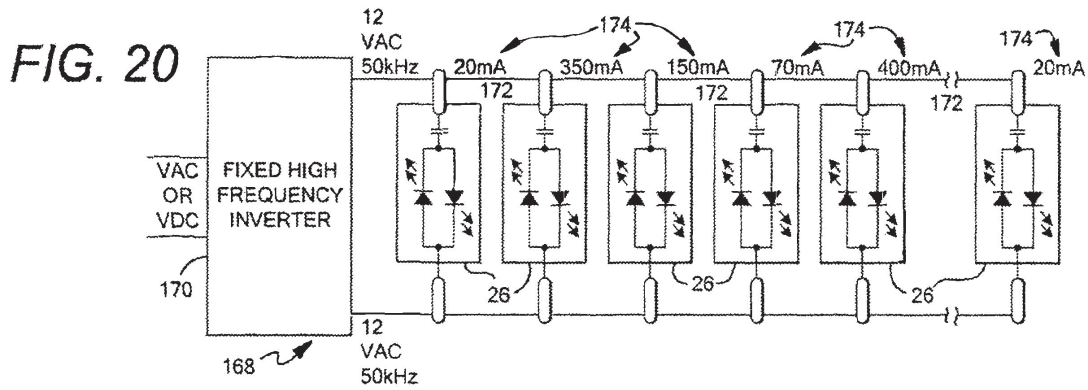

FIG. 20

FIG. 21

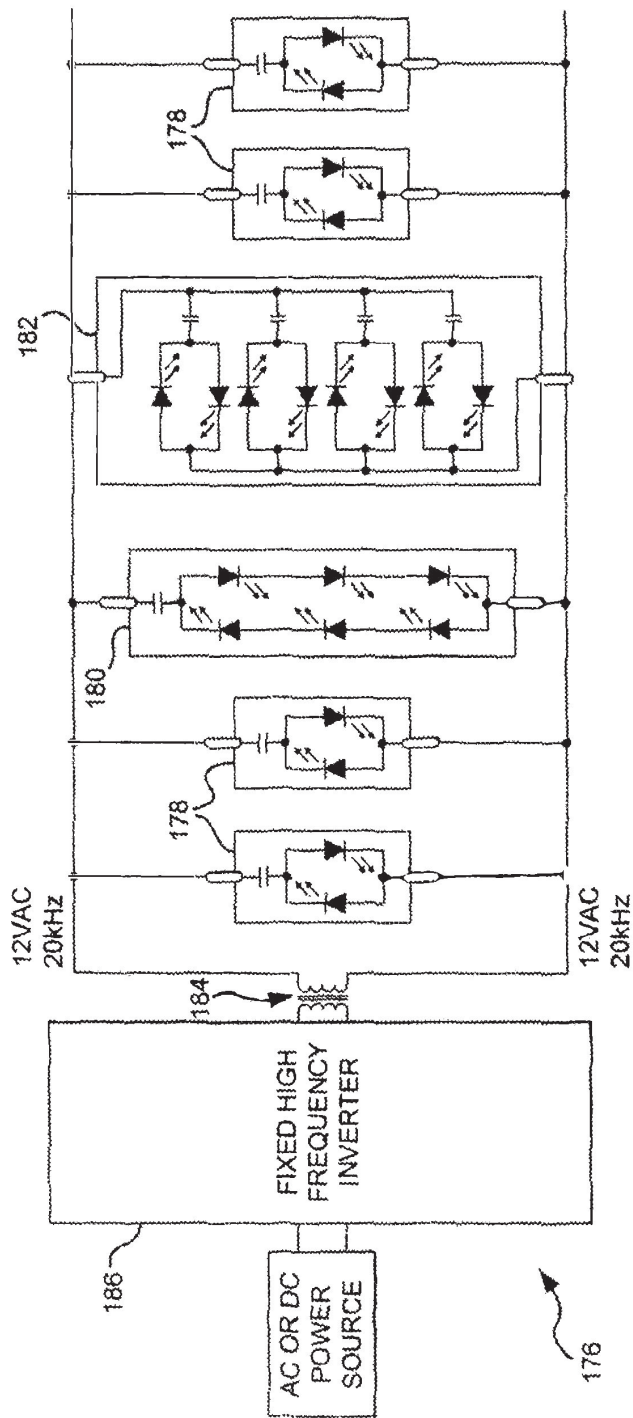
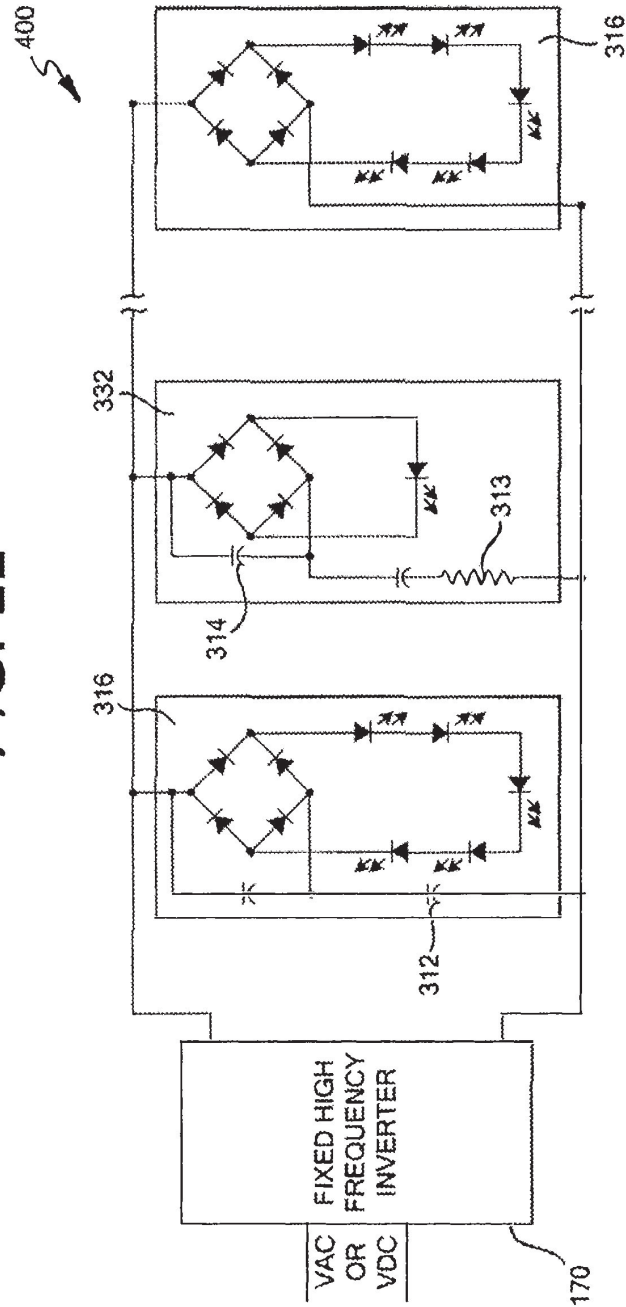

FIG. 22



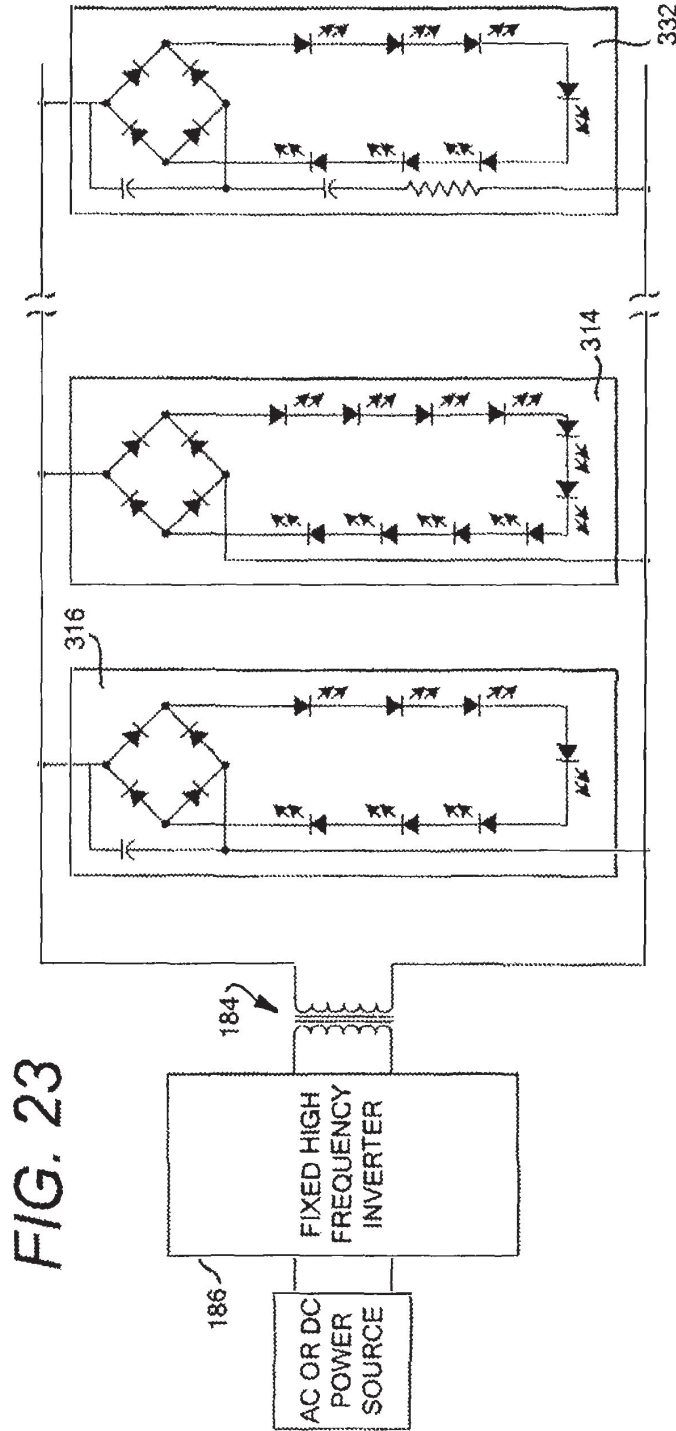

FIG. 23

FIG. 24

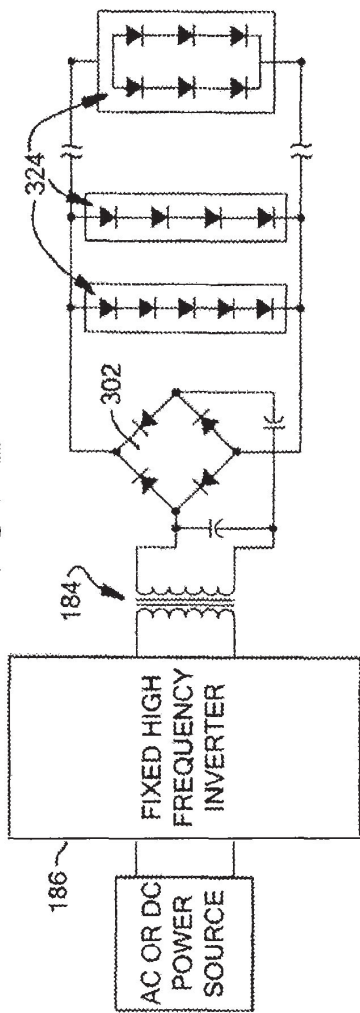

FIG. 25

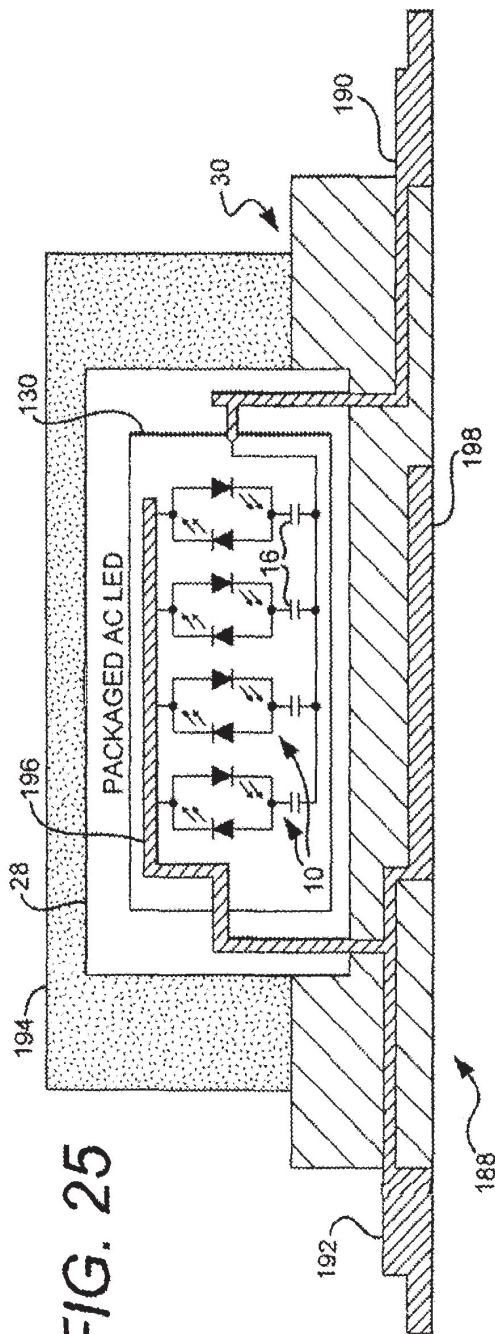

FIG. 26

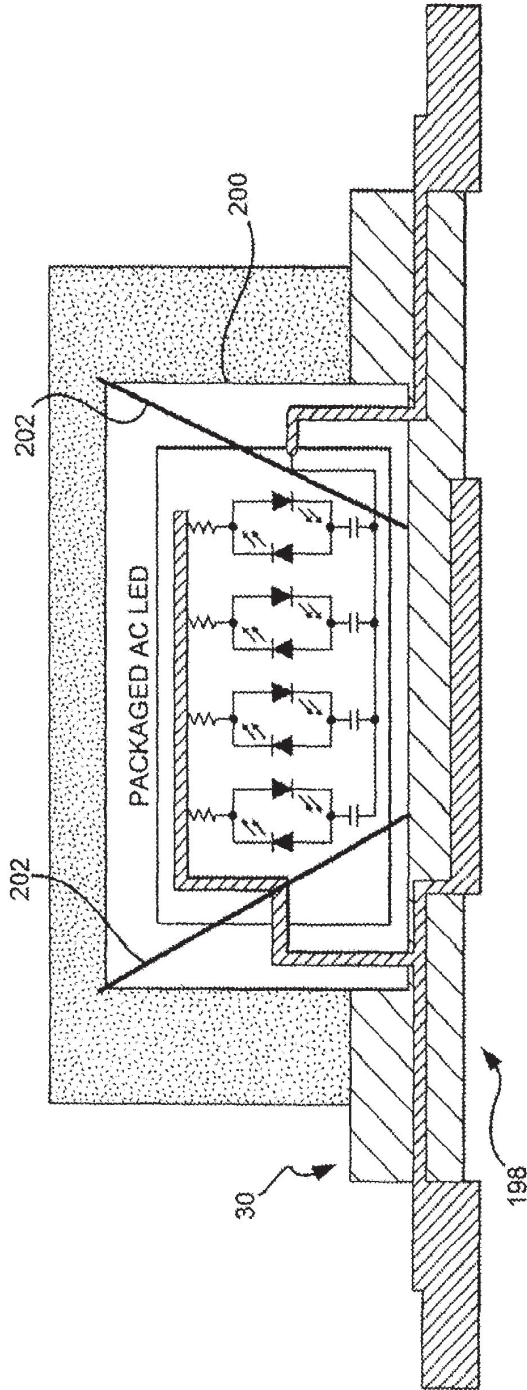
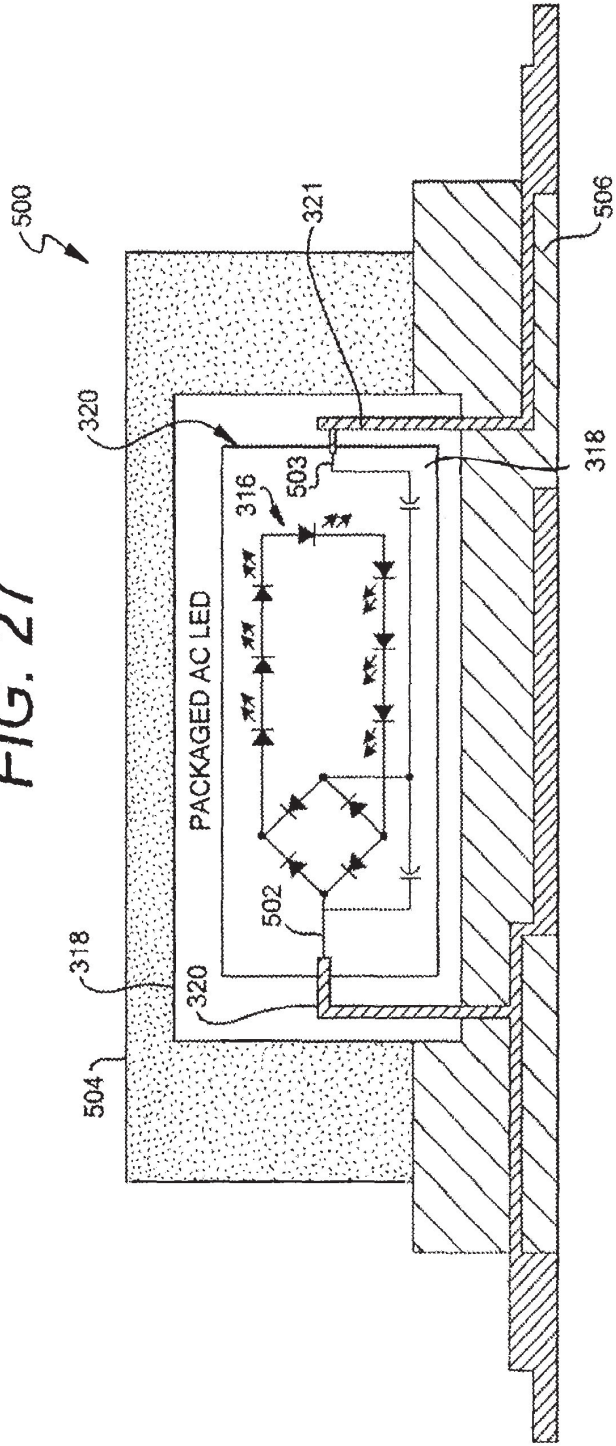

FIG. 27



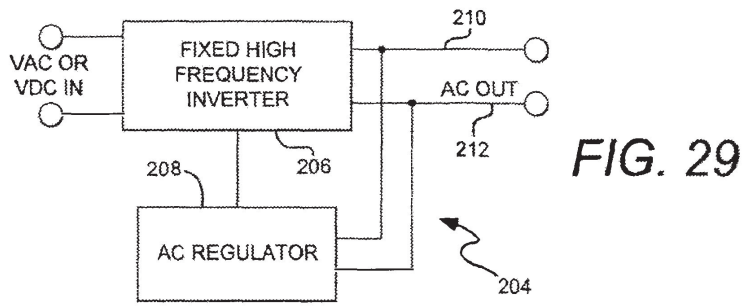
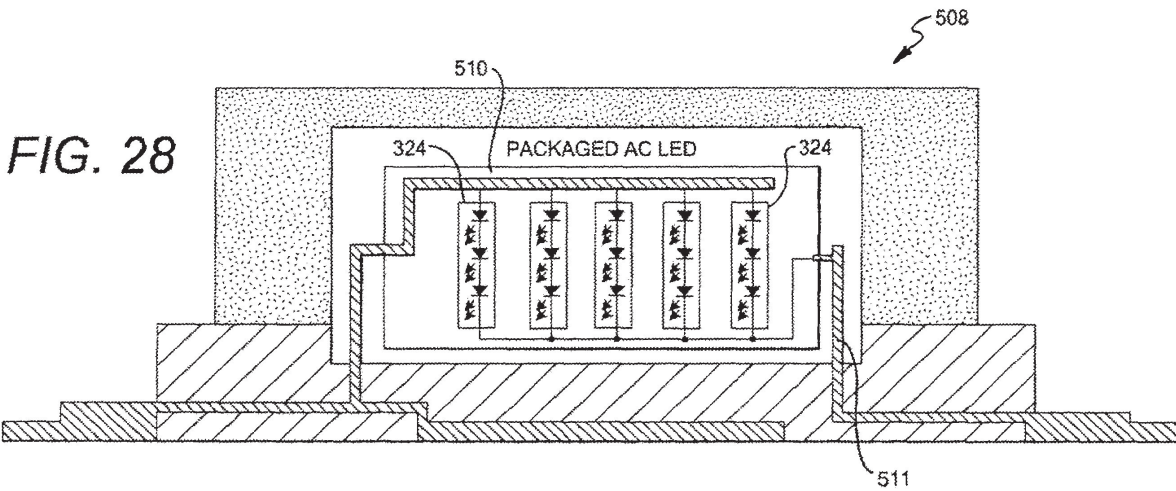
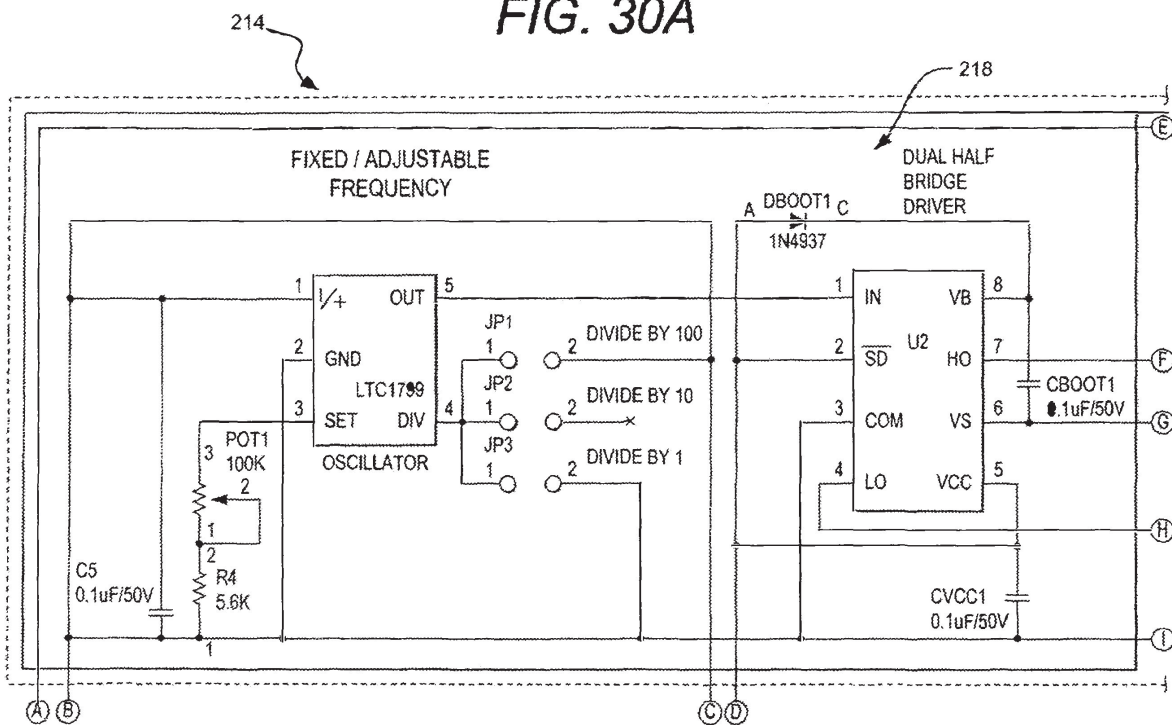
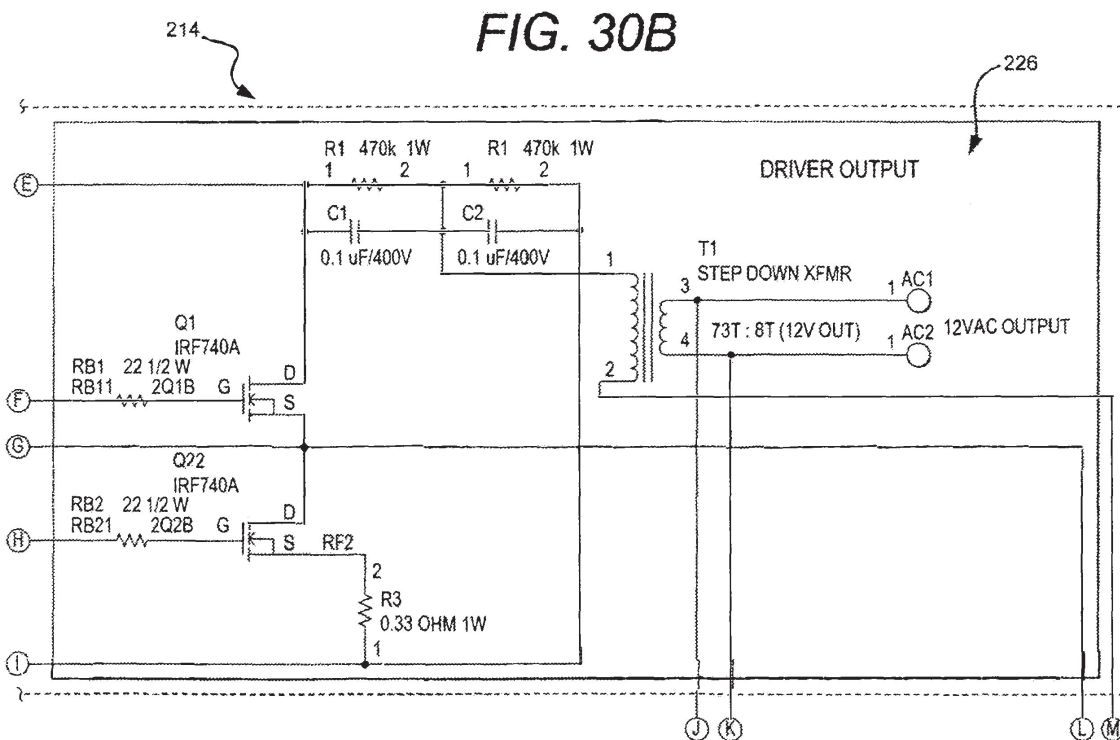
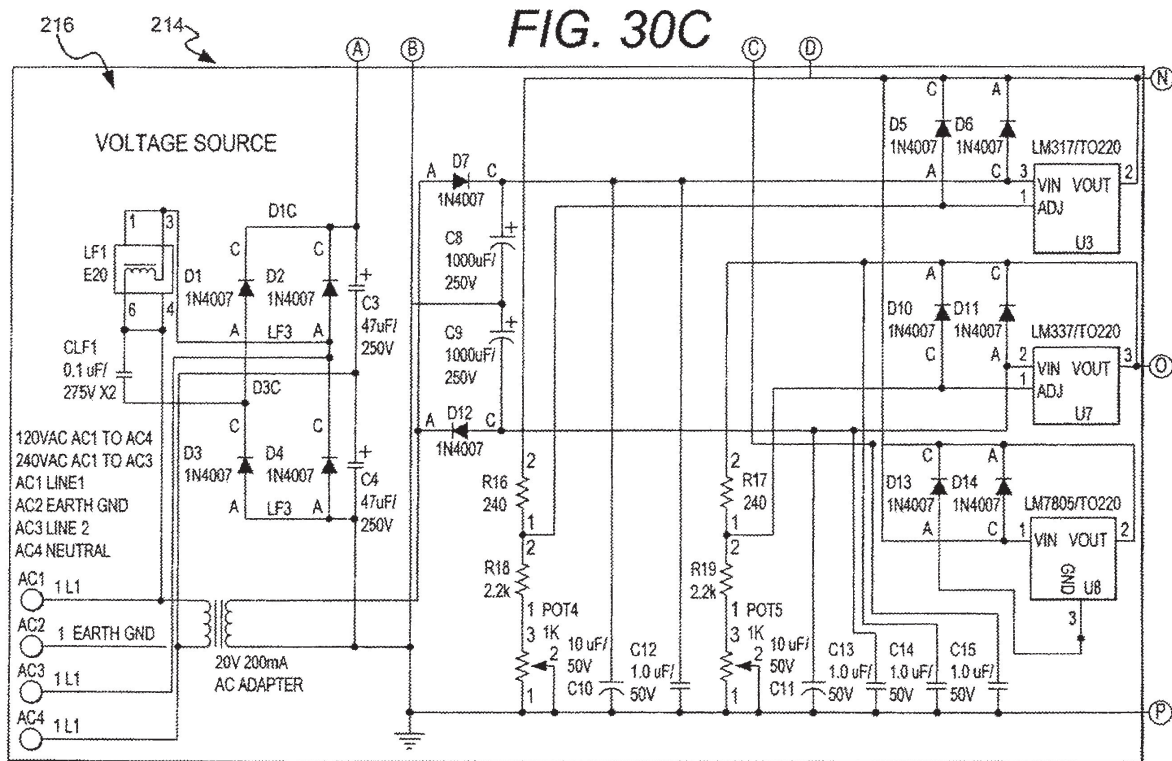

FIG. 30A



U.S. Patent Jun. 16, 2020 Sheet 14 of 48 US 10,687,400 B2





U.S. Patent Jun. 16, 2020 Sheet 16 of 48 US 10,687,400 B2

FIG. 30D

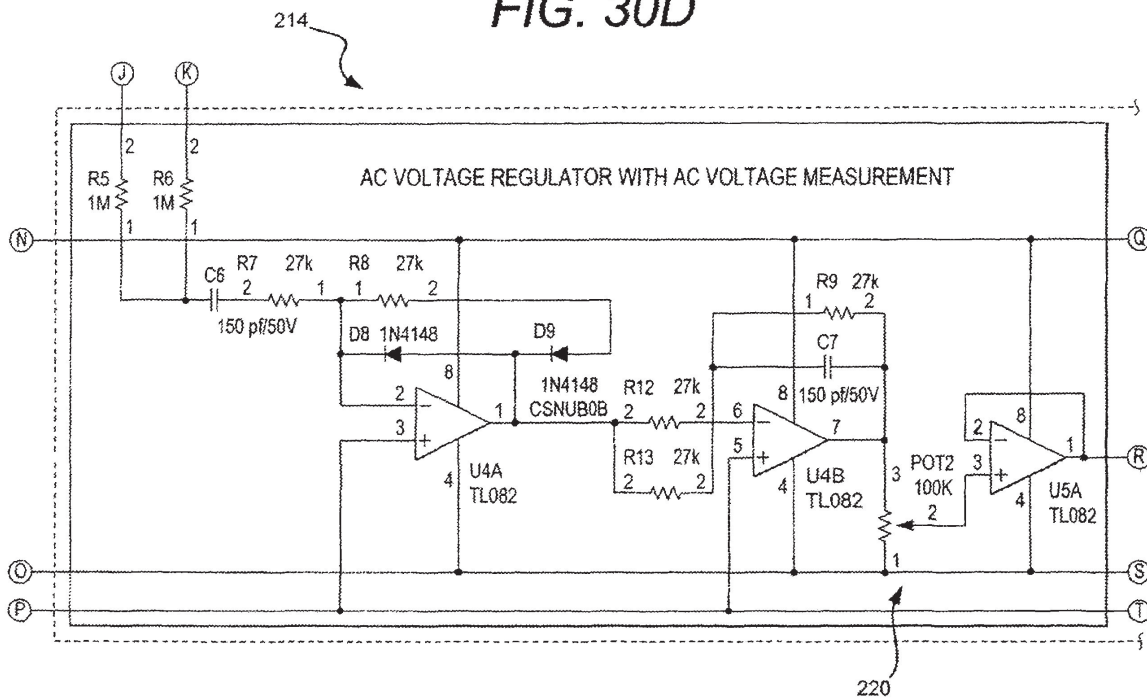

U.S. Patent Jun. 16, 2020 Sheet 17 of 48 US 10,687,400 B2

FIG. 30E

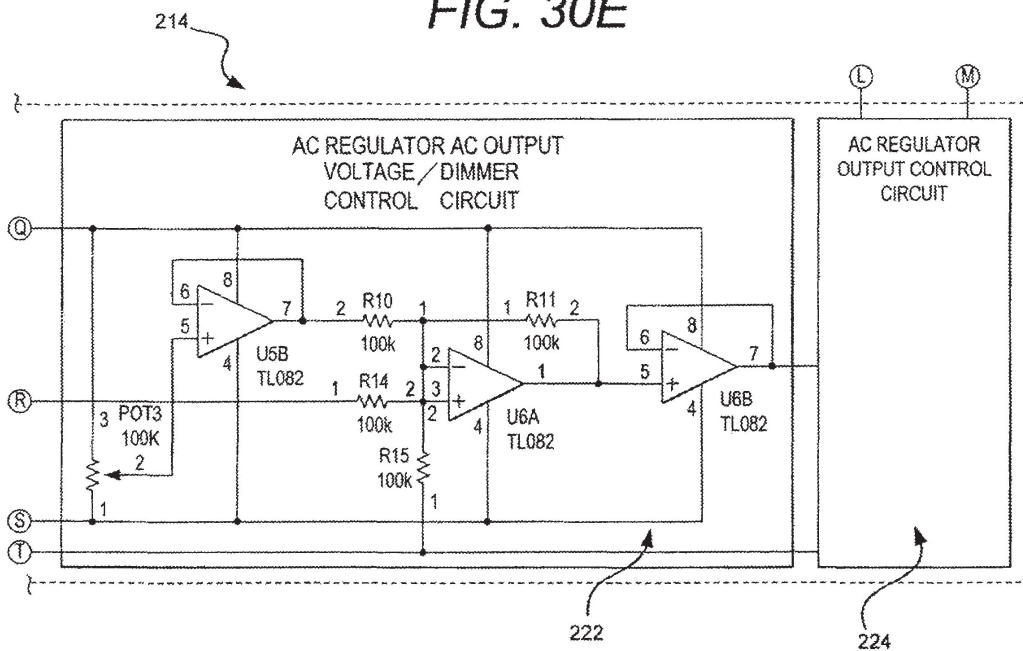

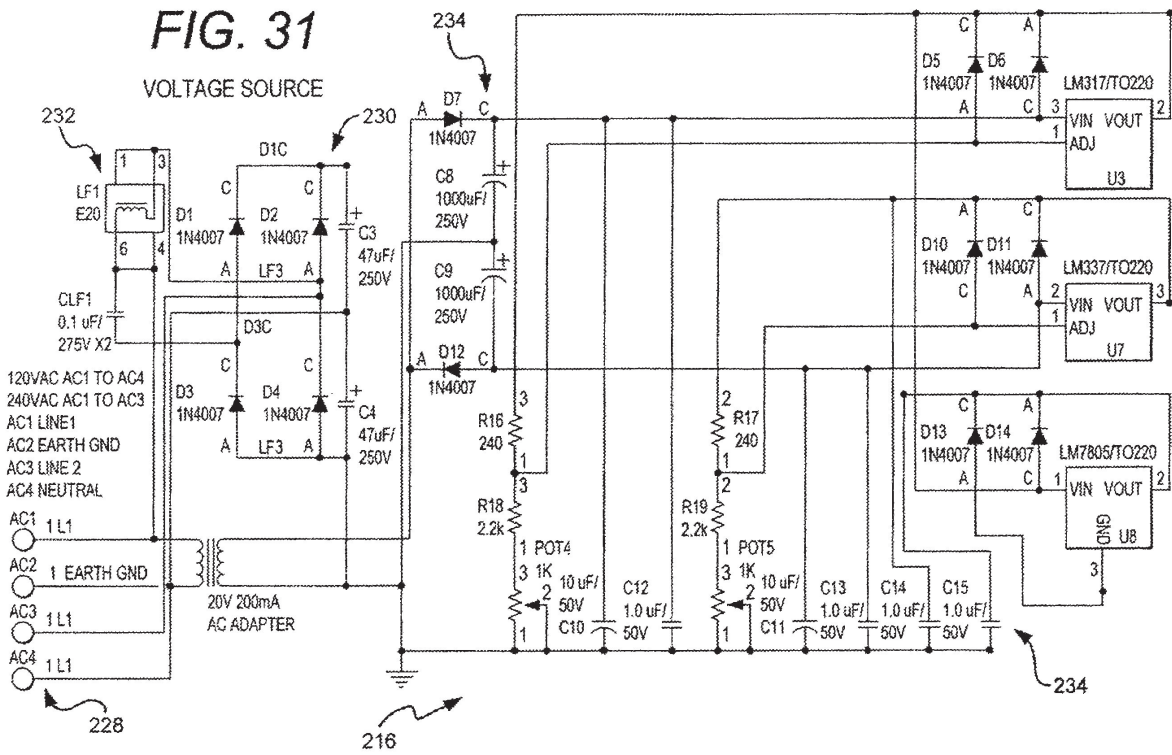

FIG. 32

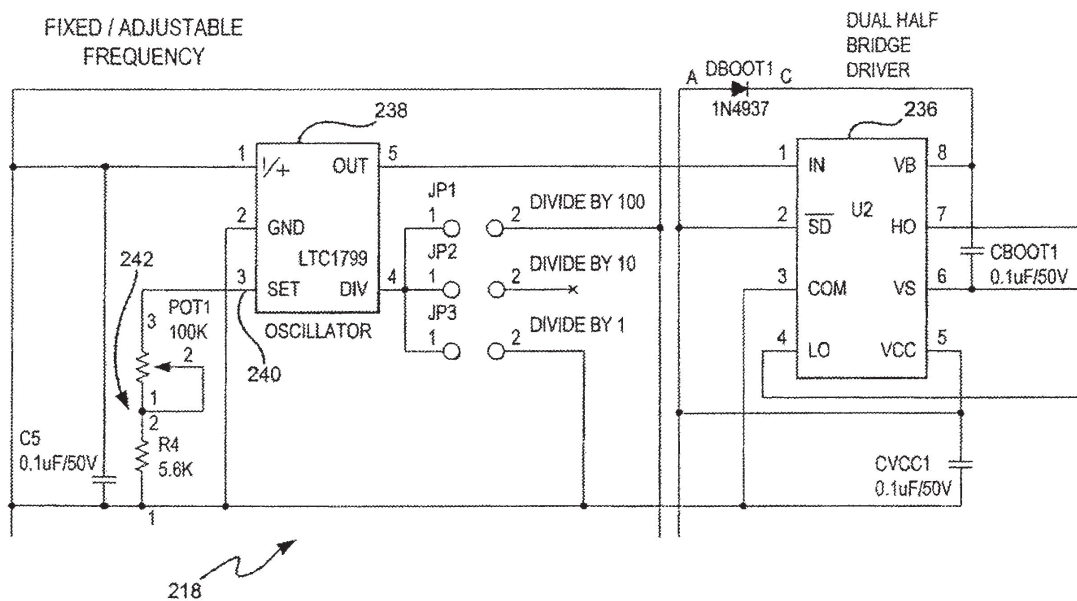
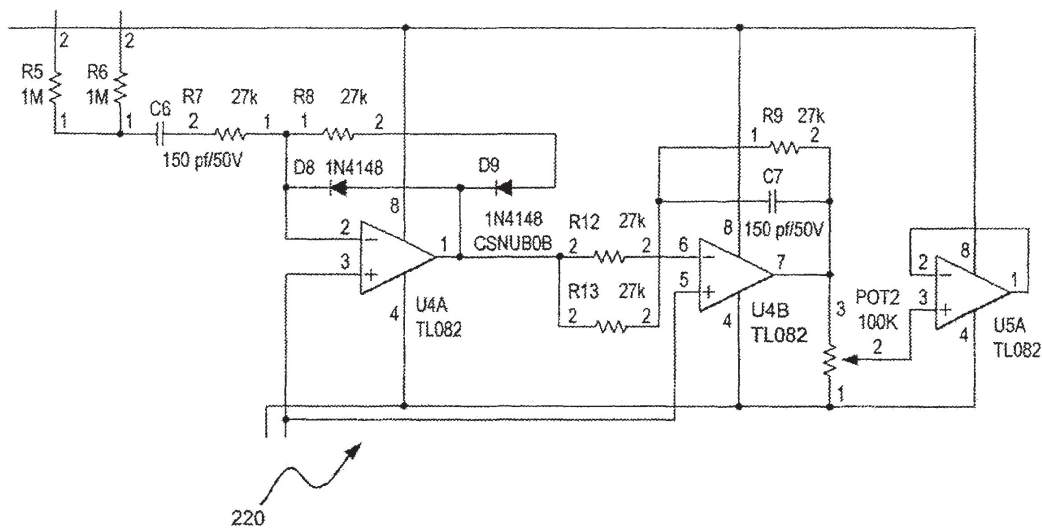

FIG. 33

AC VOLTAGE REGULATOR WITH VOLTAGE MEASUREMENT



U.S. Patent

Jun. 16, 2020

Sheet 21 of 48

US 10,687,400 B2

FIG. 34

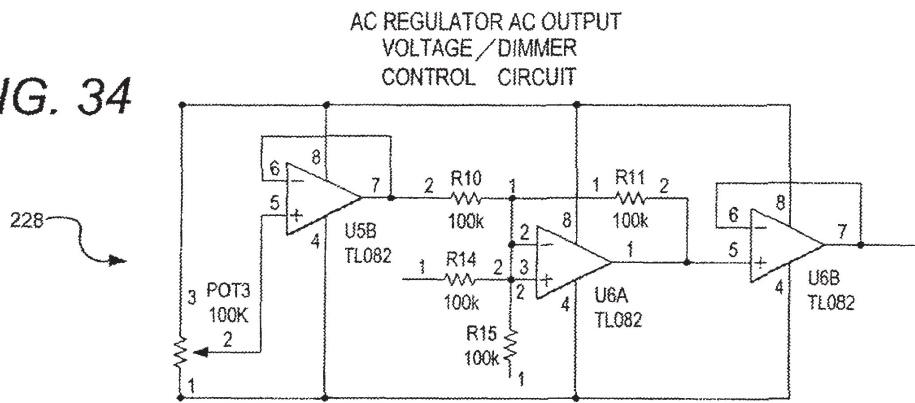

FIG. 36

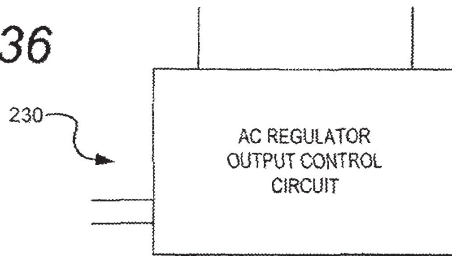
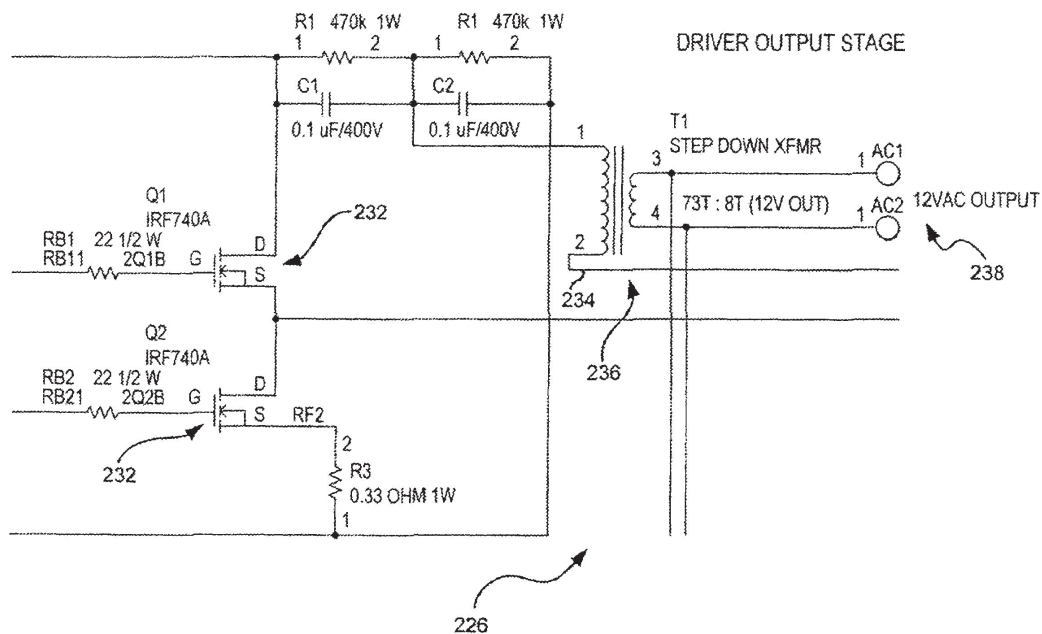

FIG. 35



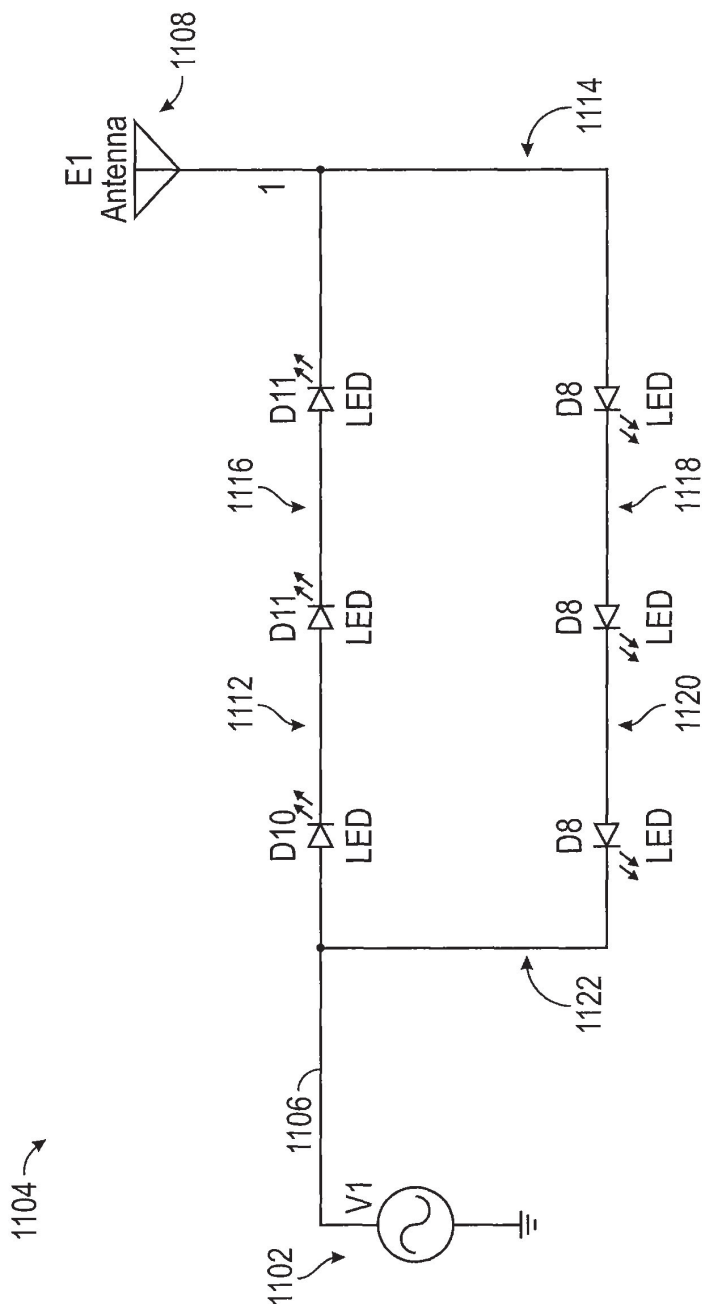

FIG. 37

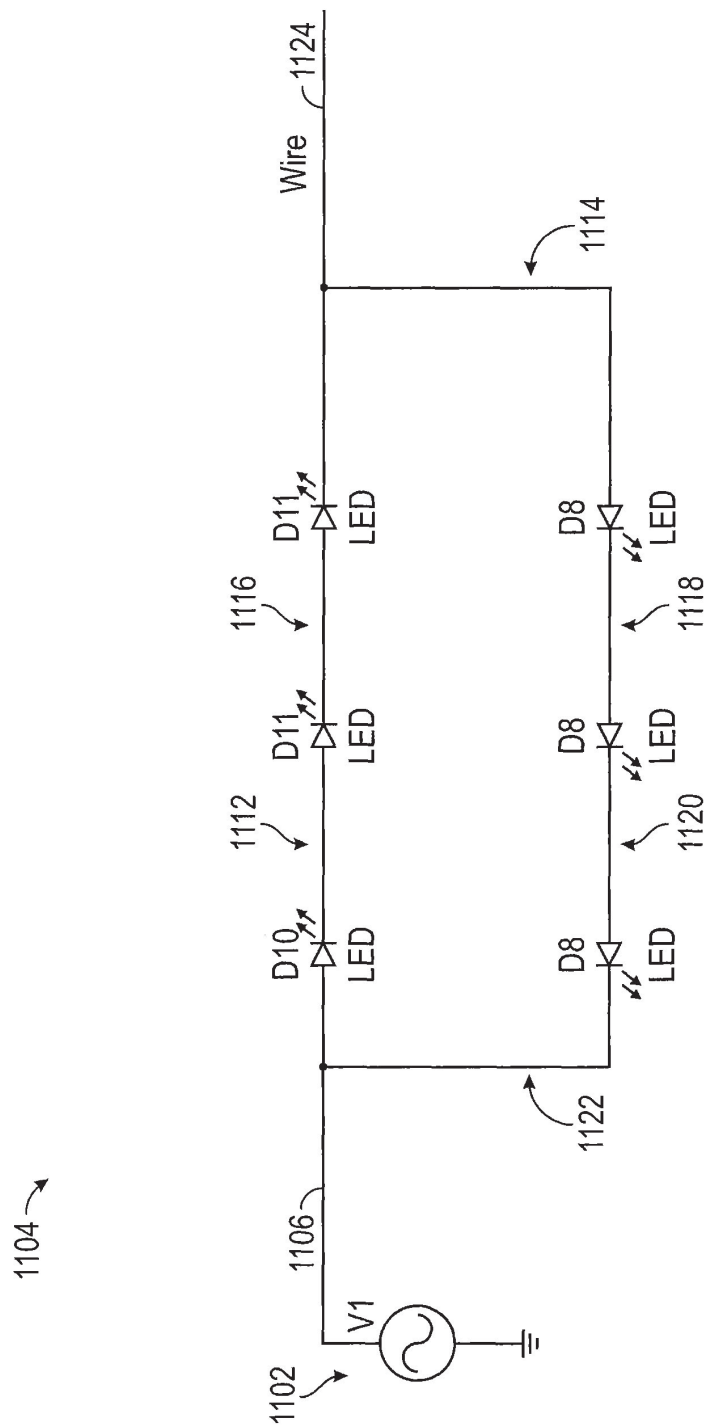

FIG. 38

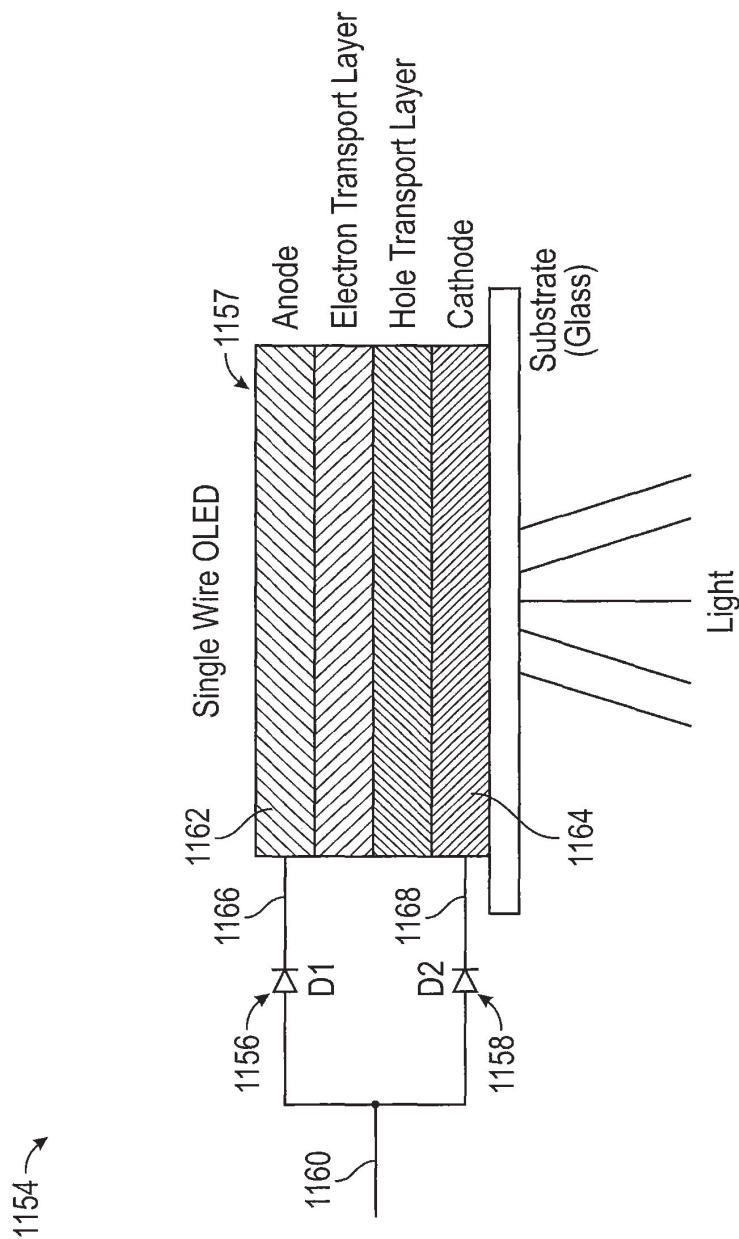

FIG. 39

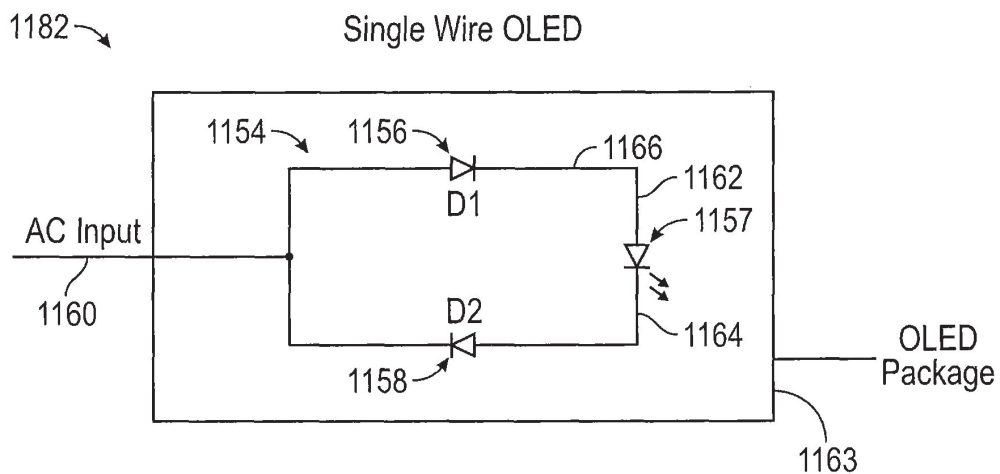

FIG. 40

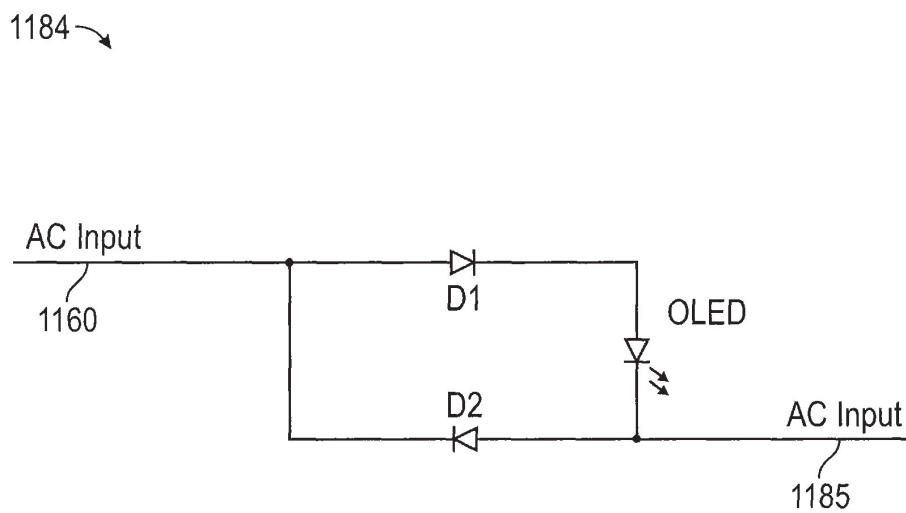

FIG. 41

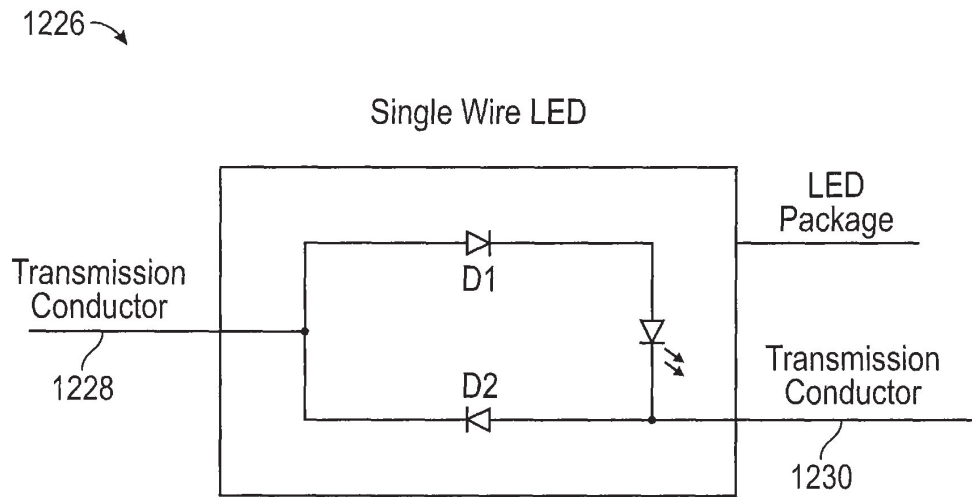

FIG. 42

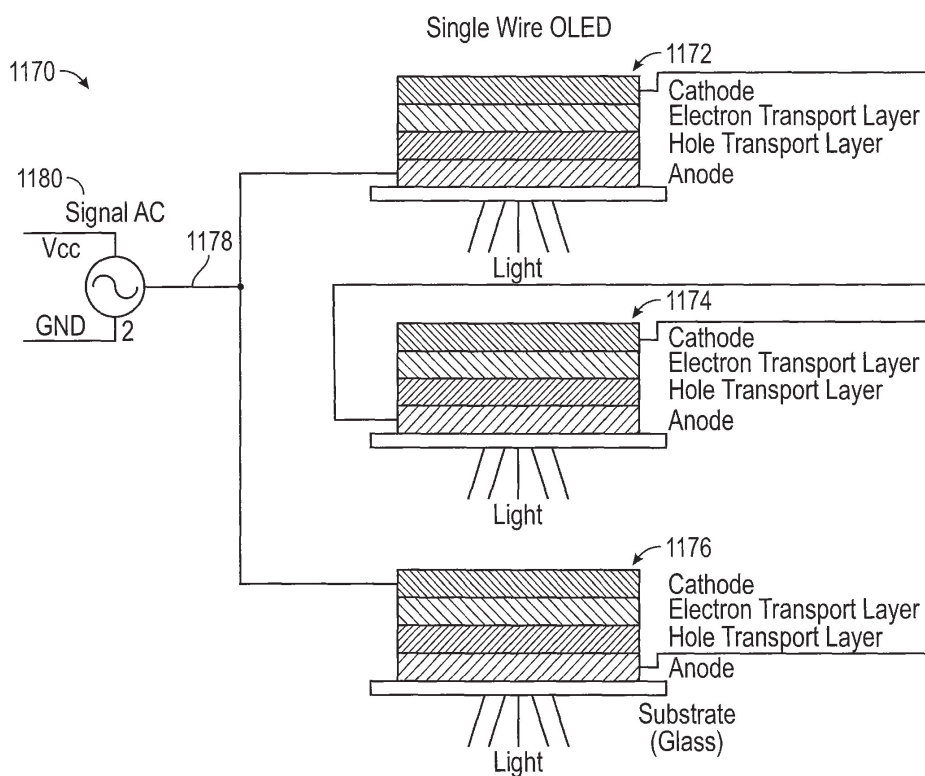

FIG. 43

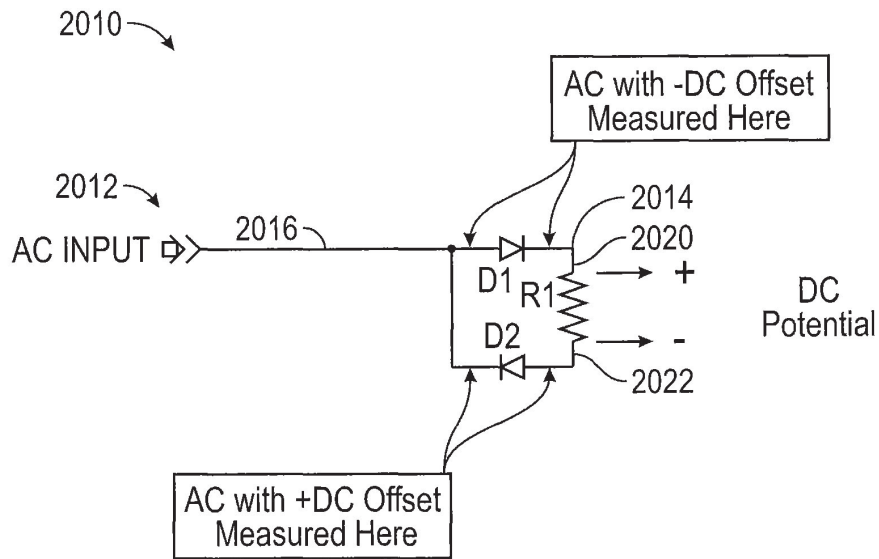

FIG. 44

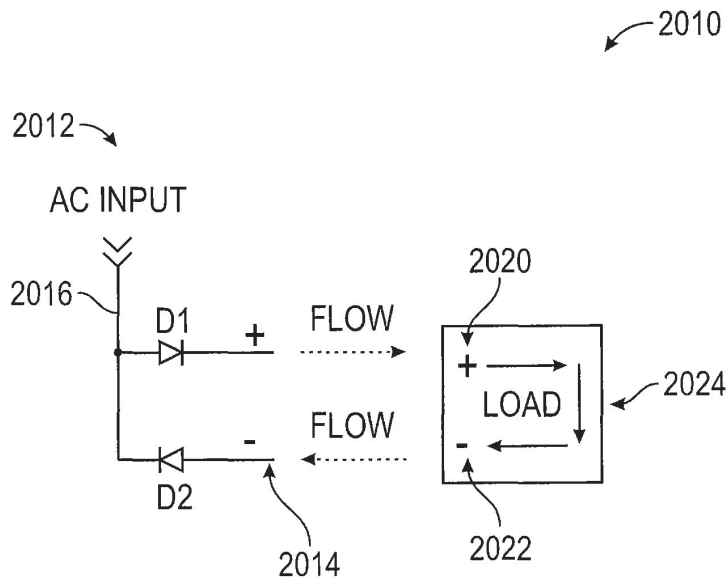

FIG. 45

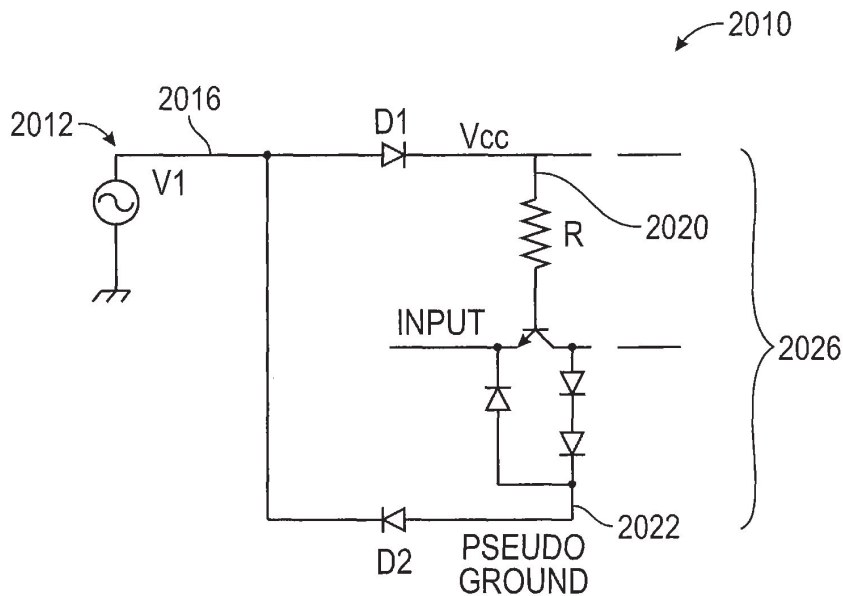

FIG. 46

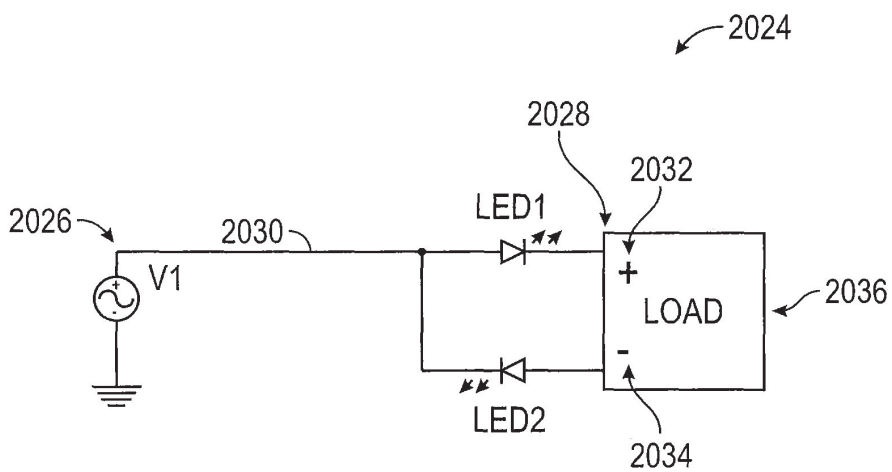

FIG. 47

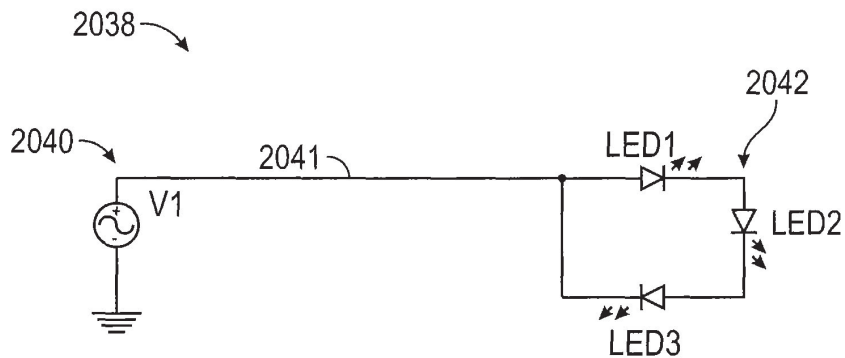

FIG. 48

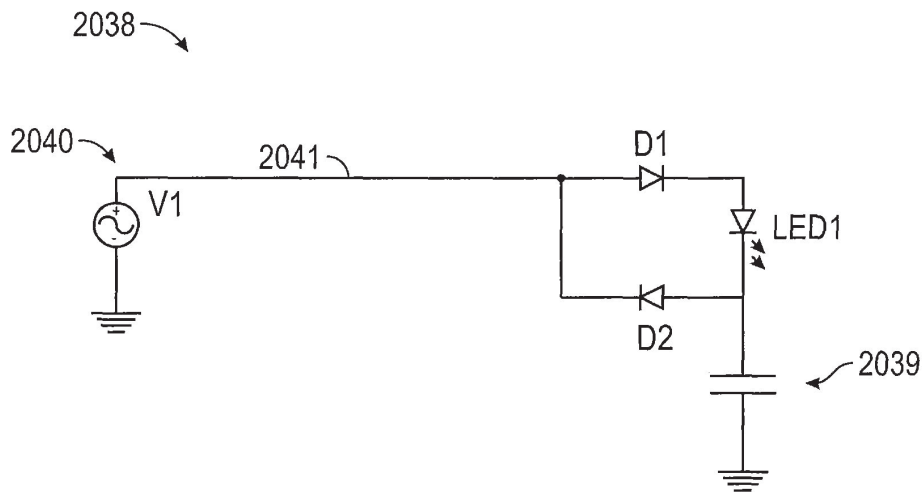

FIG. 49

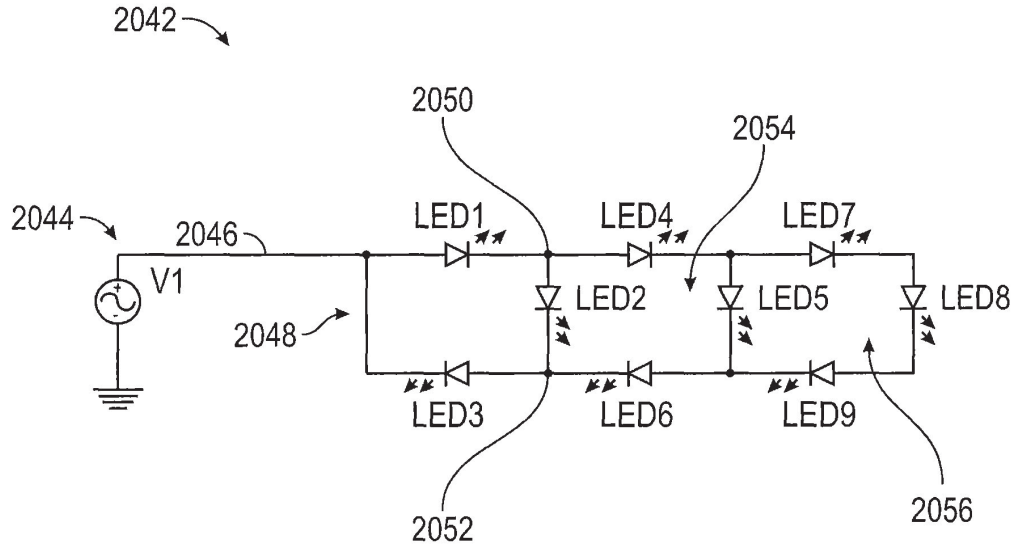

FIG. 50

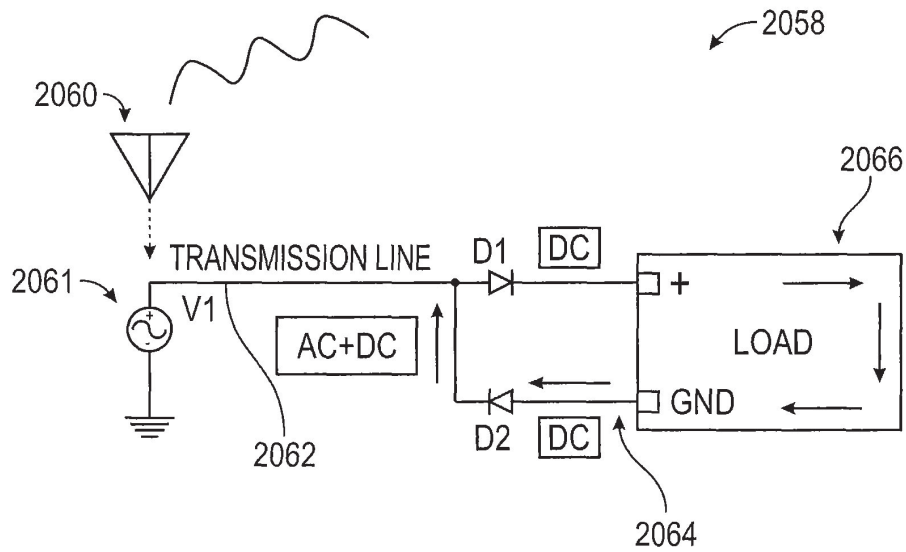

FIG. 51

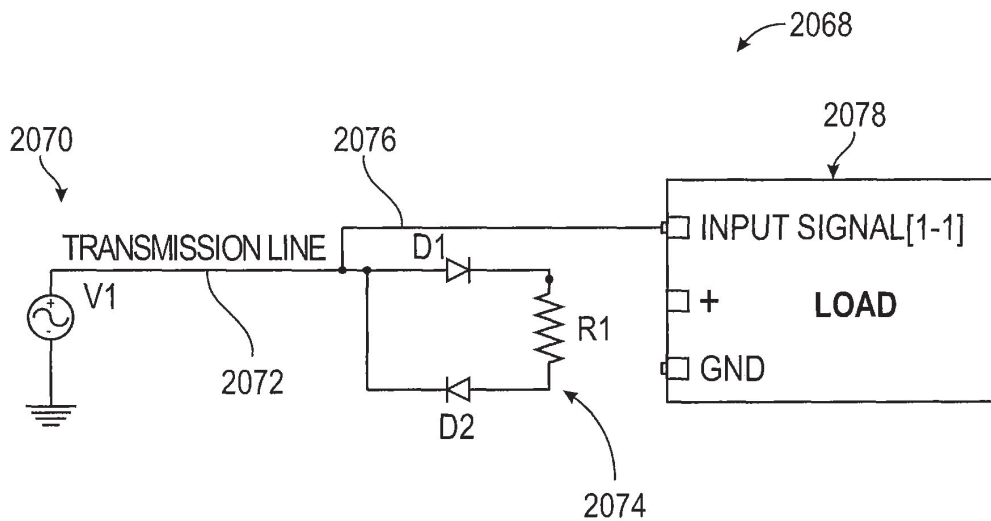

FIG. 52

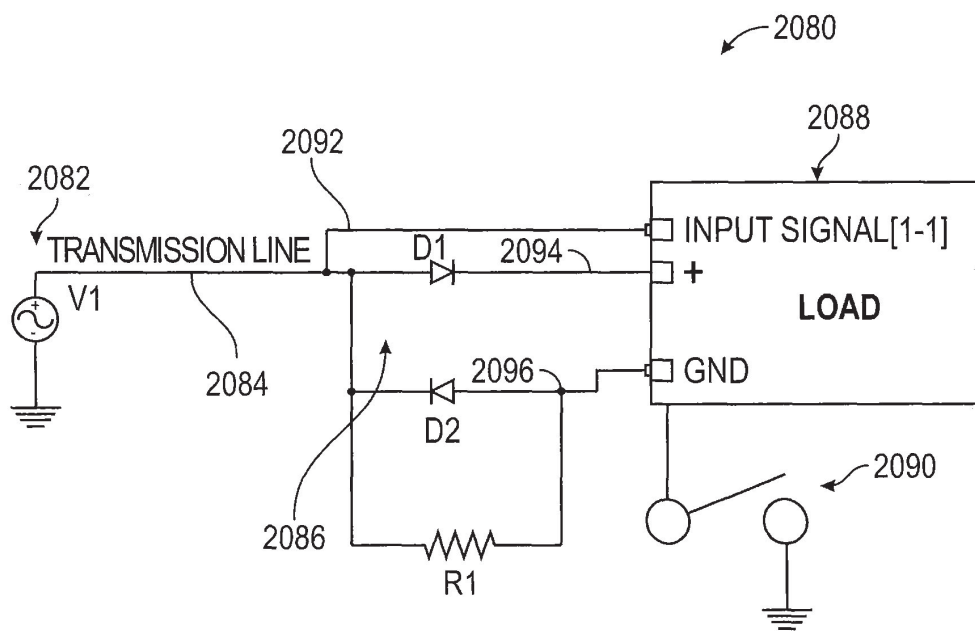

FIG. 53

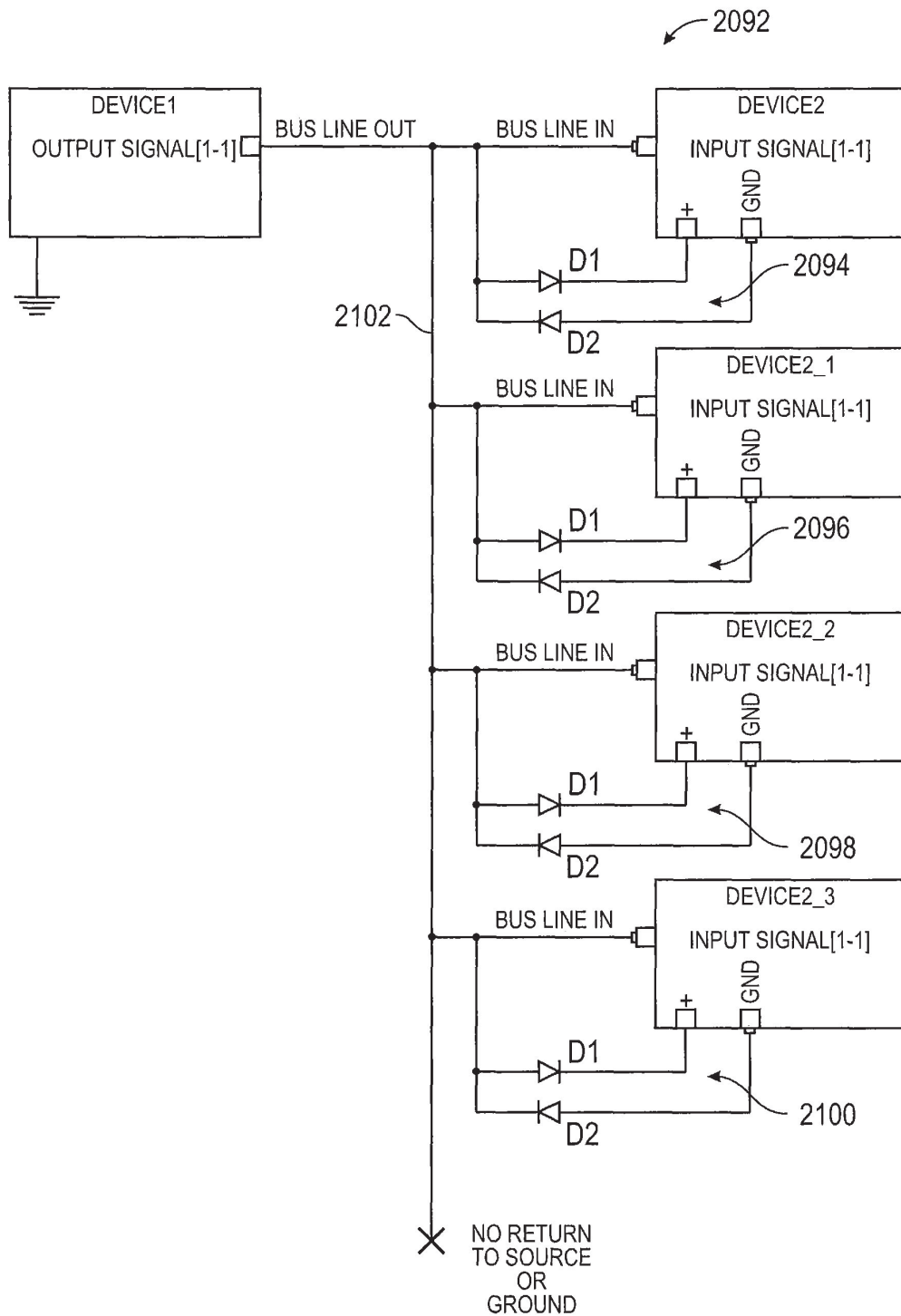

FIG. 54

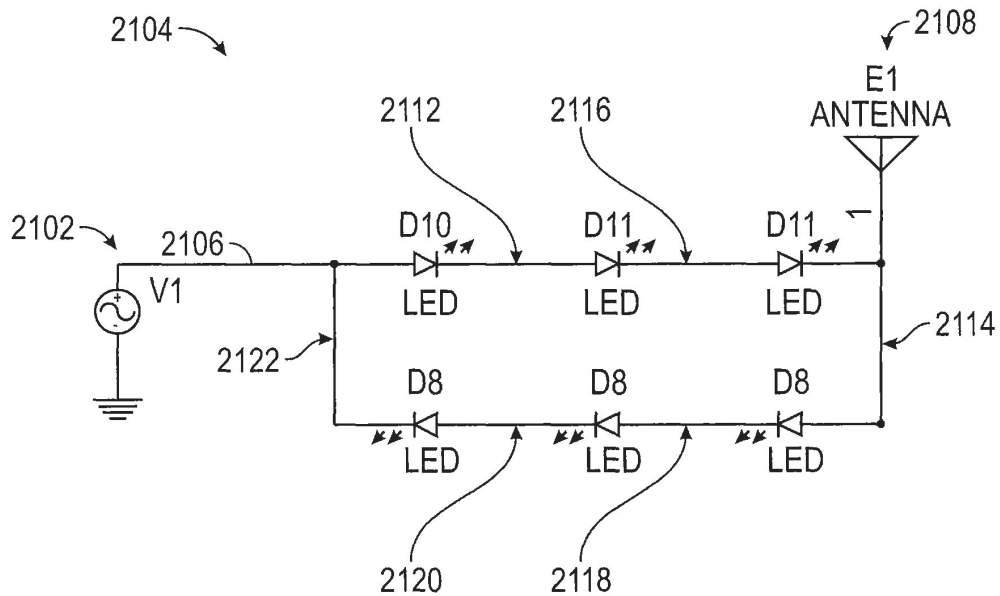

FIG. 55

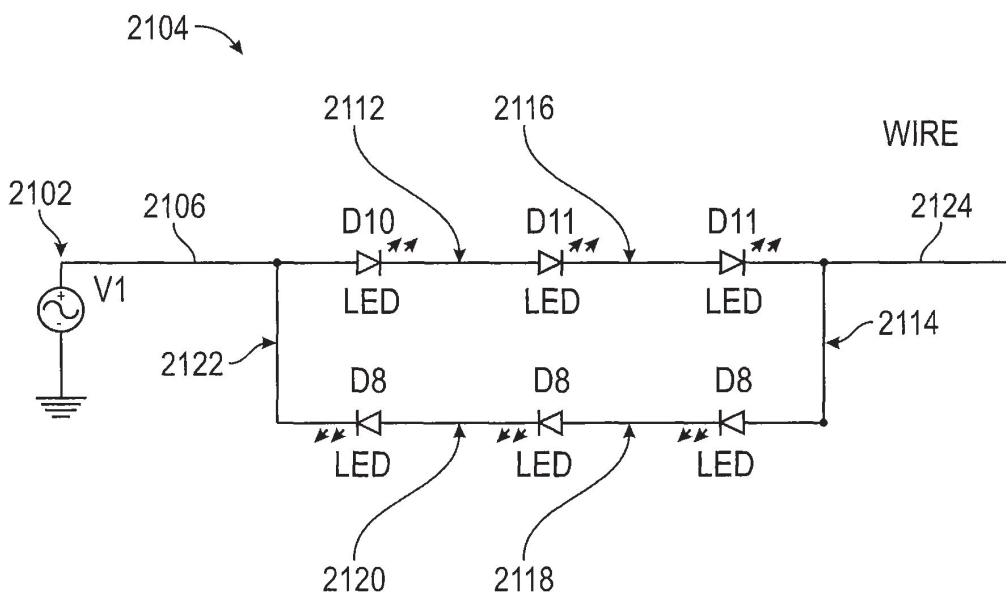
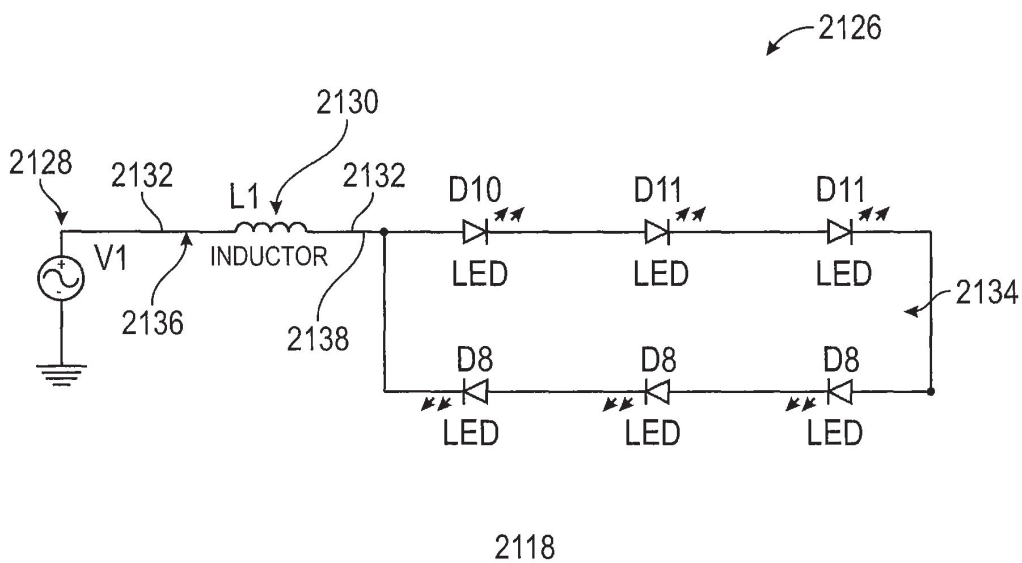

FIG. 56



2118
FIG. 57

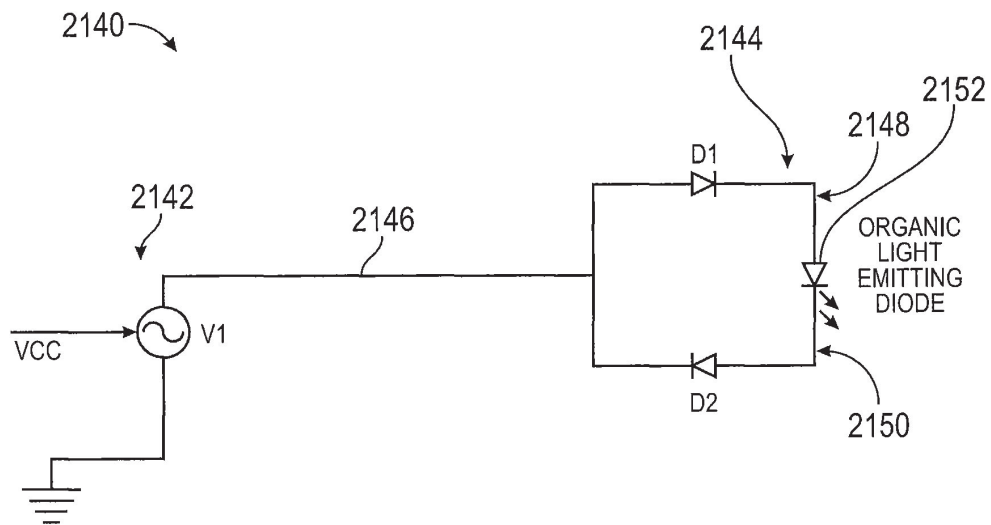

FIG. 58

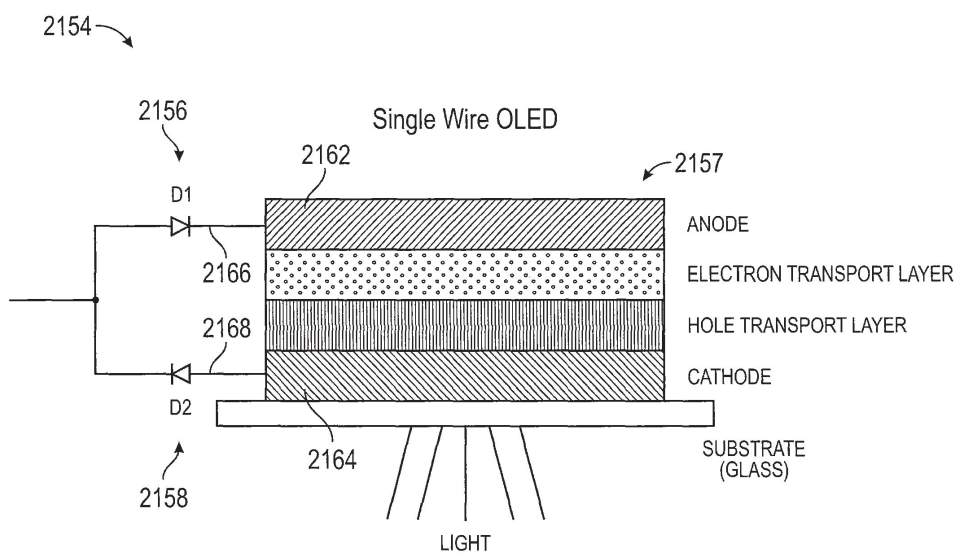

FIG. 59

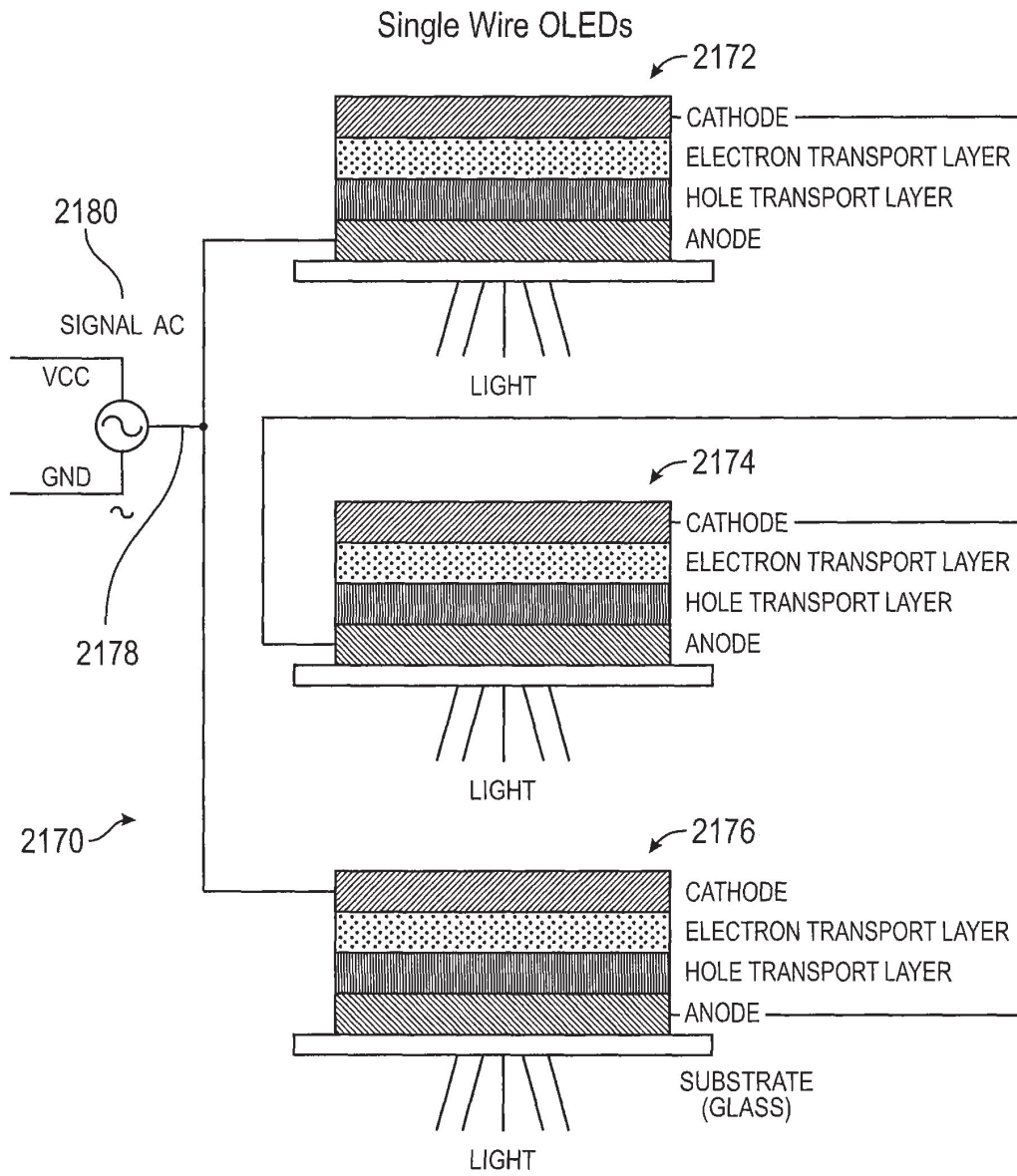

FIG. 60

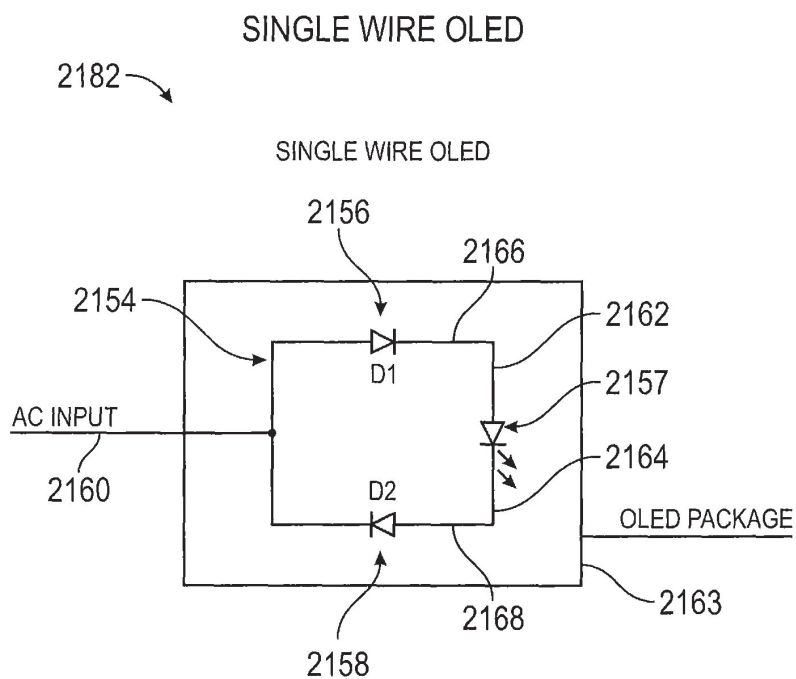

FIG. 61

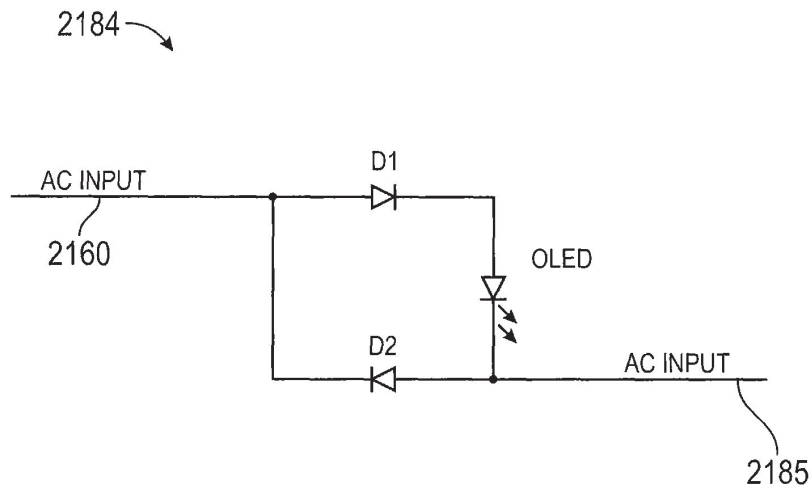

FIG. 62

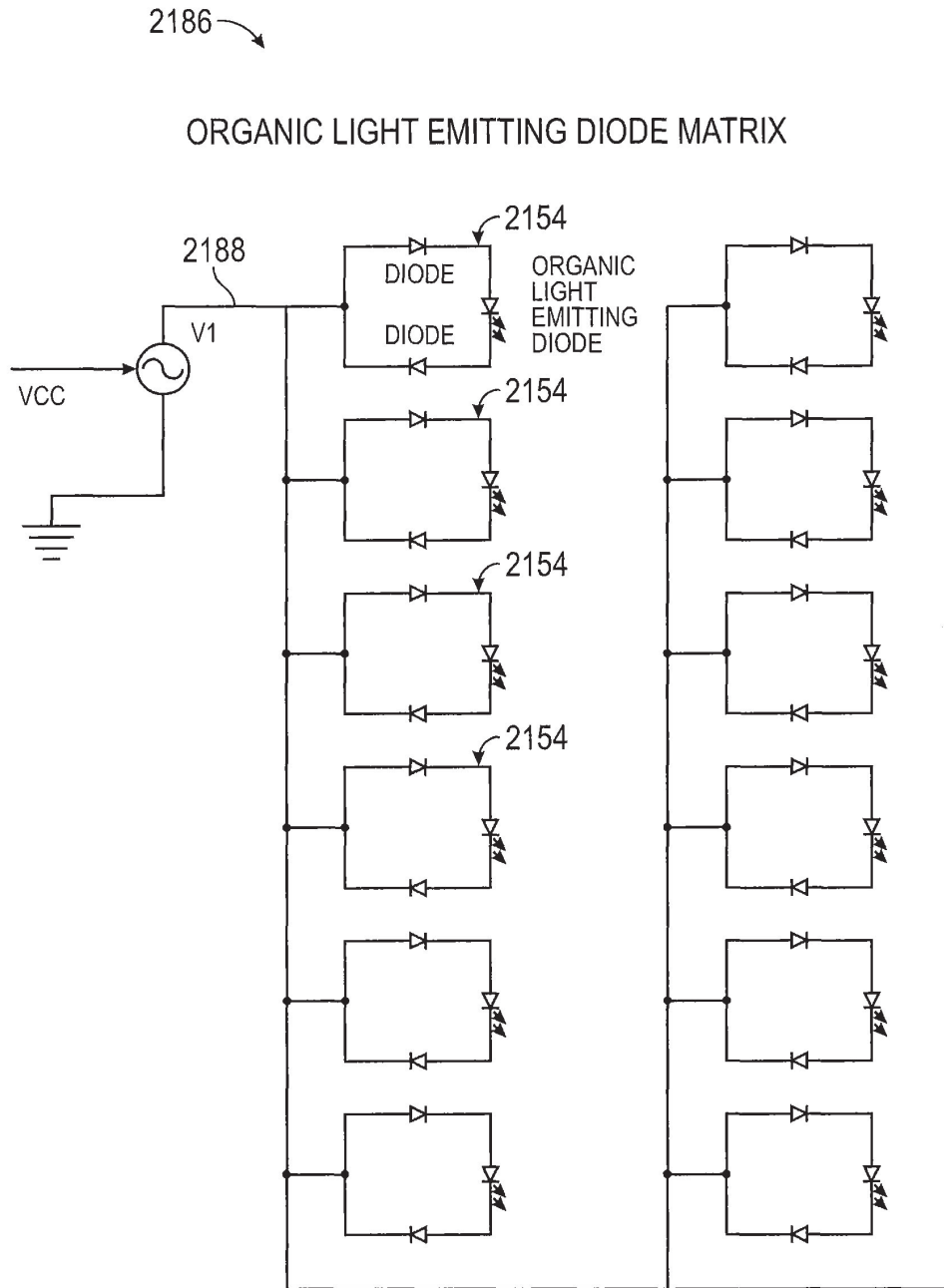

FIG. 63

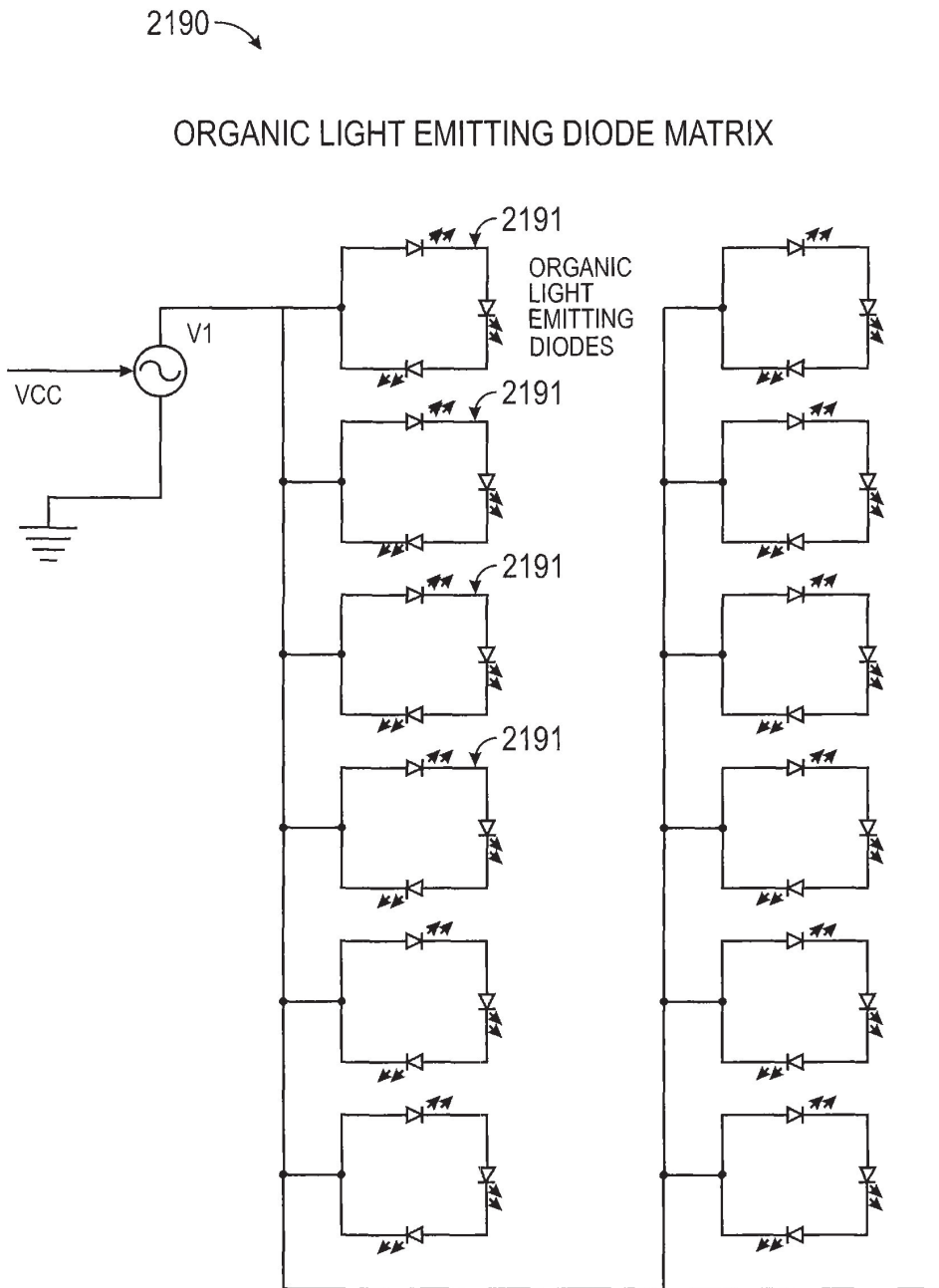

FIG. 64

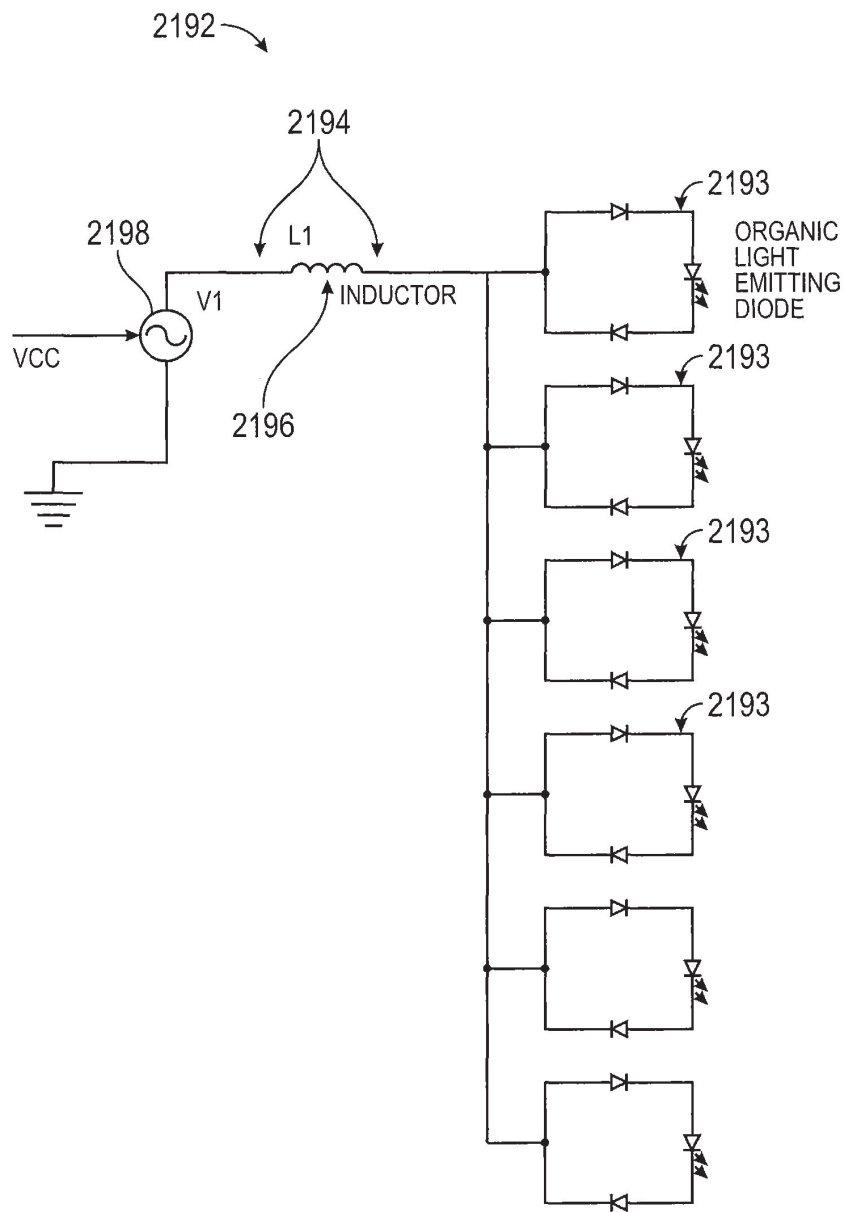

FIG. 65

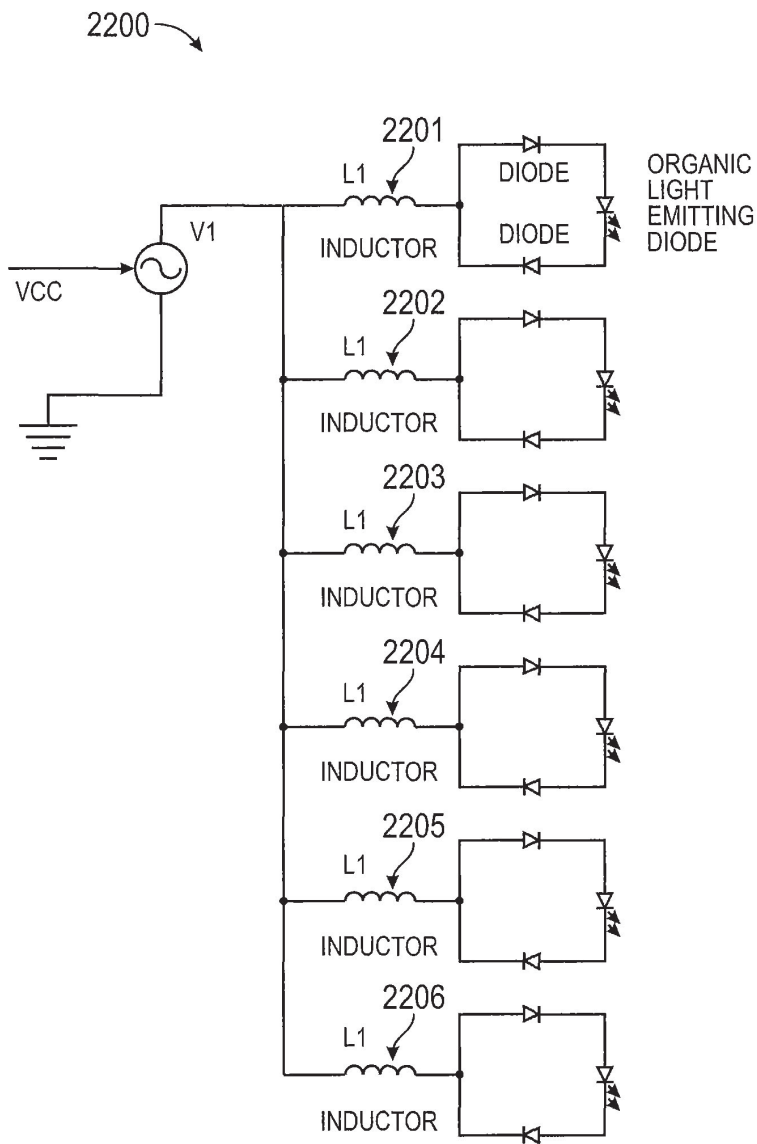

FIG. 66

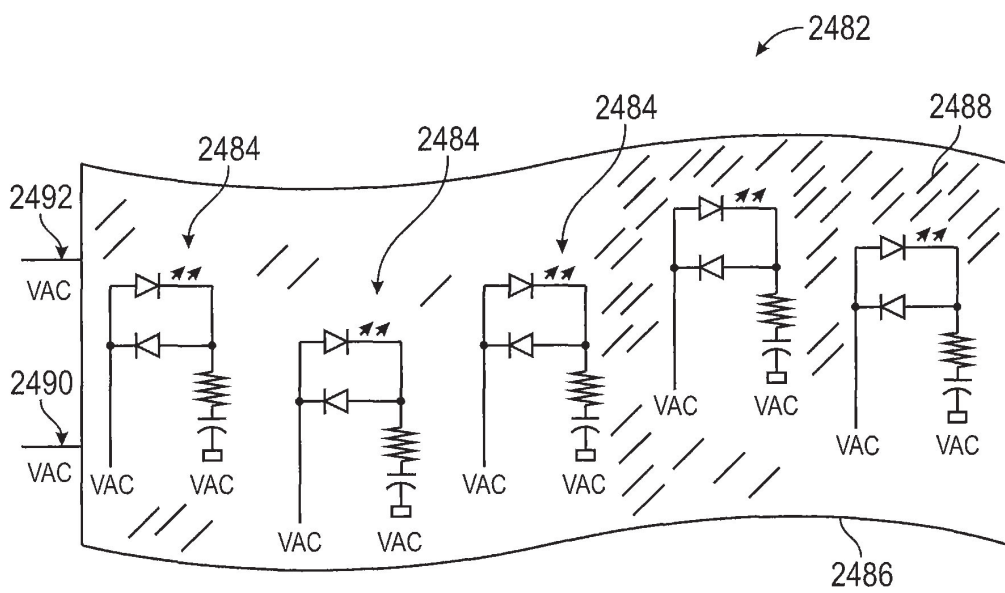

FIG. 67

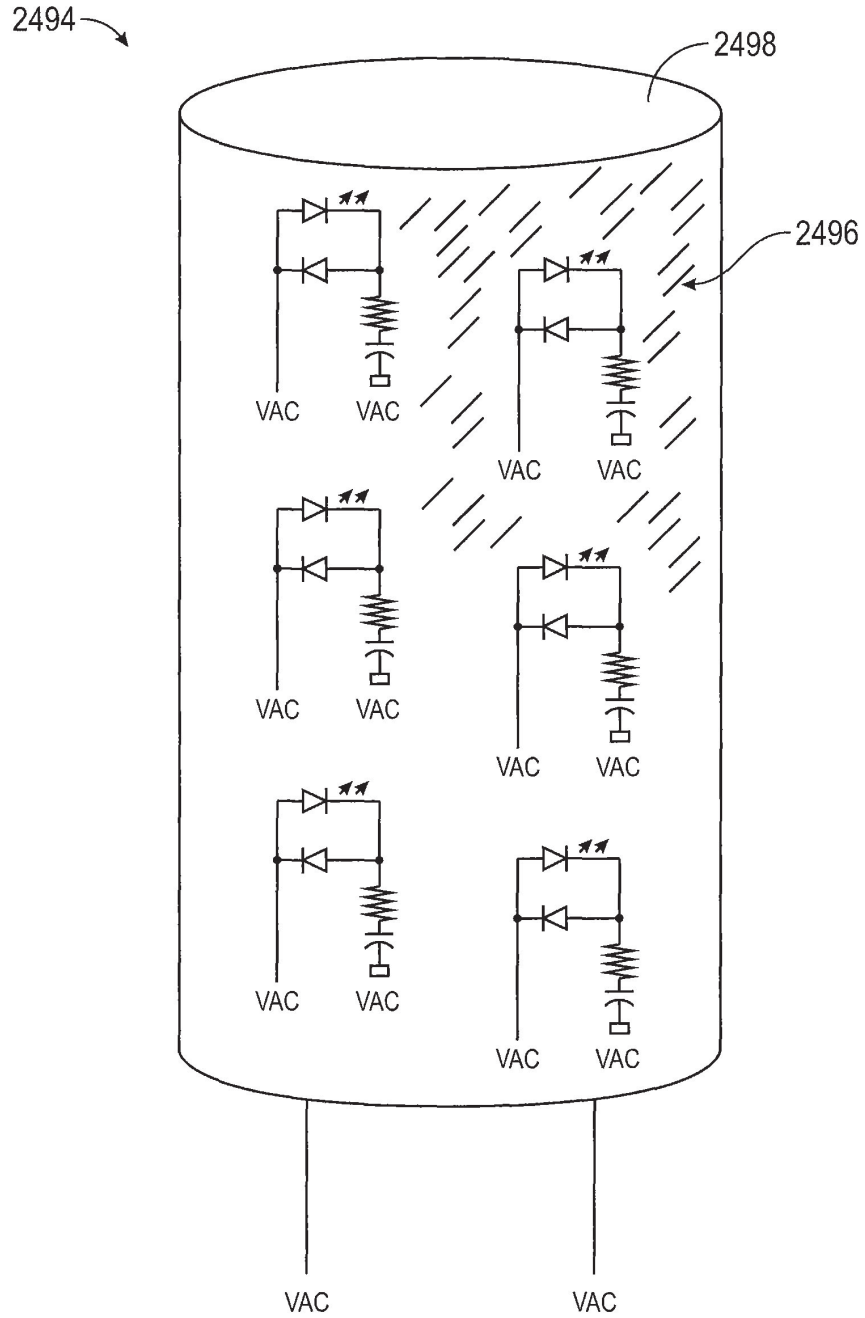

FIG. 68

US 10,687,400 B2

1

AC LIGHT EMITTING DIODE AND AC LED DRIVE METHODS AND APPARATUS

RELATED APPLICATIONS

The present application is a continuation of U.S. patent application Ser. No. 16/449,273 filed Jun. 21, 2019, which is a continuation of U.S. patent application Ser. No. 16/443,759 filed Jun. 17, 2019, which is a continuation of U.S. patent application Ser. No. 16/407,076 filed May 8, 2019, which is a continuation of U.S. patent application Ser. No. 16/148,945 filed Oct. 1, 2018, which is a continuation of U.S. patent application Ser. No. 15/334,029 filed Oct. 25, 2016, which is continuation-in-part of U.S. patent application Ser. No. 14/948,635 filed Nov. 23, 2015, which is a divisional application of U.S. patent application Ser. No. 13/697,646 filed Nov. 13, 2012 which is a 371 National Phase Application of International Application No. PCT/US2011/0363359 filed May 12, 2011 which claims priority to U.S. Provisional Application No. 61/333,963 filed May 12, 2010 and is a continuation-in-part of International Application No. PCT/US2010/062235 filed Dec. 28, 2010 which claims priority to U.S. Provisional Application No. 61/284,927 filed Dec. 28, 2009 and U.S. Provisional Application No. 61/335,069 filed Dec. 31, 2009 and is a continuation-in-part of U.S. patent application Ser. No. 12/287,267, filed Oct. 6, 2008, which claims priority to U.S. Provisional Application No. 60/997,771, filed Oct. 6, 2007; U.S. patent application Ser. No. 12/364,890 filed Feb. 3, 2009 which is a continuation of U.S. application Ser. No. 11/066,414 (now U.S. Pat. No. 7,489,086) filed Feb. 25, 2005 which claims priority to U.S. Provisional Application No. 60/547,653 filed Feb. 25, 2004 and U.S. Provisional Application No. 60/559,867 filed Apr. 6, 2004; International Application No. PCT/US2010/001597 filed May 28, 2010 which is a continuation-in-part of U.S. application Ser. No. 12/287,267, and claims priority to U.S. Provisional Application No. 61/217,215, filed May 28, 2009; International Application No. PCT/US2010/001269 filed Apr. 30, 2010 which is a continuation-in-part of U.S. application Ser. No. 12/287,267, and claims priority to U.S. Provisional Application No. 61/215,144, filed May 1, 2009; the contents of each of these applications are expressly incorporated herein by reference.

TECHNICAL FIELD

The present invention generally relates to light emitting diodes ("LEDs") and LED drivers. The present invention specifically relates to alternating current ("AC") driven LEDs, LED circuits and AC drive circuits and methods.

FEDERALLY SPONSORED RESEARCH OR DEVELOPMENT

None.

BACKGROUND OF THE INVENTION

1. Field of the Invention

The present invention generally relates to light emitting diodes ("LEDs") and LED drivers. The present invention specifically relates to alternating current ("AC") driven LEDs, LED circuits and AC drive circuits and methods.

2. Description of the Related Art

LEDs are semiconductor devices that produce light when a current is supplied to them. LEDs are intrinsically DC

2

devices that only pass current in one polarity and historically have been driven by DC voltage sources using resistors, current regulators and voltage regulators to limit the voltage and current delivered to the LED. Some LEDs have resistors built into the LED package providing a higher voltage LED typically driven with 5V DC or 12V DC.

With proper design considerations LEDs may be driven more efficiently with AC than with DC drive schemes. LED based lighting may be used for general lighting, specialty lighting, signs and decoration such as for Christmas tree lighting. For example, U.S. Pat. No. 5,495,147 entitled LED LIGHT STRING SYSTEM to Lanzisera (hereinafter "Lanzisera") and U.S. Pat. No. 4,984,999 entitled STRING OF LIGHTS SPECIFICATION to Leake (hereinafter "Leake") describes different forms of LED based light strings. In both Lanzisera and Leake, exemplary light strings are described employing purely parallel wiring of discrete LED lamps using a step-down transformer and rectifier power conversion scheme. This type of LED light string converts input electrical power, usually assumed to be the common U.S. household power of 110 VAC, to a low voltage, rectified to nearly DC input.

Pat. Pending Application No. 0015968A1 entitled PREFERRED EMBODIMENT TO LED LIGHT STRING to Allen (hereinafter "Allen") discloses AC powered LED-based light strings. Allen describes LED light strings employing series parallel blocks with a voltage matching requirement for direct AC drive placing fundamental restrictions on the number of diodes (LEDs) on each diode series block, depending on the types of diodes used. Allen discloses that for the forward voltage to be "matched," in each series block, the peak input voltage must be less than or equal to the sum of the maximum forward voltages for each series block in order to prevent over-driving.

LEDs can be operated from an AC source more efficiently if they are connected in an "opposing parallel" configuration as shown by WO98/02020 and JP11/330561. More efficient LED lighting systems can be designed using high frequency AC drivers as shown by Patent Publication Number 20030122502 entitled Light Emitting Diode Driver ("Clauberg et. al.") Clauberg et. al. discloses that higher frequency inverters may be used to drive an opposing parallel LED pair, an opposing parallel LED string and/or an opposing parallel LED matrix by coupling the LEDs to a high frequency inverter through a resonant impedance circuit that includes a first capacitor coupled in series to one or more inductors with the impedance circuit coupled in series to opposing parallel LEDs with each set of LEDs having a second series capacitor in series to the impedance circuit. In this system additional opposing parallel configurations of LEDs with capacitors may not be added to or removed from the output of the driver without effecting the lumens output of the previously connected LED circuits unless the driver or components at the driver and/or the opposing parallel LED capacitors were replaced with proper values. By adding or removing the opposing parallel LED circuits the voltage would increase or drop at the inductor and the current would increase or drop through the first series capacitor as the load changed therefore the inductor and all capacitors or entire driver would need to be replaced or adjusted each time additional LEDs were added to or removed from the system.

High frequency AC voltage power supplies and/or transformers can be used to drive LEDs by interfacing a bridge between the power supply and a DC driven LED circuit(s) or having no bridge between the high frequency transformer and an AC driven LED circuit(s).

US 10,687,400 B2

3

High frequency AC transformers can be made smaller and more cost effectively than constant current or constant voltage DC drivers or power supplies currently being used to power LEDs.

The higher the frequency, the smaller the transformer can be made. With proper design consideration and based on the wattage and the frequency of the AC voltage output, a high frequency AC voltage transformer can be made small enough to be mounted directly onto a LED lighting PCB assembly.

Patent application number US2004/0080941 entitled Light Emitting Diodes For High AC Voltage Operation And General Lighting discloses that a plurality of opposing parallel series strings of LEDs can be integrated into a single chip and driven with high voltage low frequency mains AC power sources as long as there are enough LEDs in each opposing parallel series string of LEDs to drop the total source voltage across the series LEDs within the chip. Patent numbers WO2004023568 and JP2004006582 disclose that a plurality of opposing parallel series strings or opposing parallel series matrix of LEDs can be integrated into a single chip and mounted on an insulating substrate and driven with a high drive voltage and low drive current as long as there are enough LEDs in each opposing parallel series string of LEDs to drop the total source voltage across the series LEDs within the chip. These patents and application disclose that for single chip or packaged LED circuits a plurality of opposing parallel series strings are required with the total number of LEDs in each series string needing to be equal to or greater than the AC voltage source in order to drop the total forward voltage and provide the required drive current when driven direct with low frequency AC mains power sources.

The present invention addresses the above-noted shortcomings of the prior art while providing additional benefits and advantages

This invention continues the line of inventions of Nikola Tesla, and Stanislav and Konstantin Avramenko. It is possible to transfer power through one wire, even to operate an electric motor. It is also possible to transfer power without any wires.

The self reference method and device goes one step ahead. For power and signal applications there are benefits in using self referencing circuits and devices without the need to bring extra objects to dissipate the energy already in place or provide a DC return path to ground or an AC power source. With precautions to protect integrated circuits and low power electronic devices, it is possible to design efficient systems when the heat, energy and the error budgets are important. It is also possible to design solid state electric power transformers that can be used in place of magnetic transformers. By reducing the number of connections inside these systems, more efficient designs are possible. It is even conceivable to design portable systems without batteries. DC powered electronic devices require a magnetic transformer and rectification when powered with 120 volt or 240 volt AC power. Additionally, they typically require a drop in supply voltage. A transformer typically reduces the high voltage and rectifies it to DC current. Solid state LED lighting can be powered with AC or DC depending on the design on the device. If rectification is not required, resistors can be used in place of a transformer to drop higher voltages. The resistors generate heat and transformers can be cumbersome as well as generate heat.

One wire electric transmission is due to displacement currents. The dipoles in matter and in the electromagnetic vacuum can move back and forth in the presence of a

4

longitudinal alternating electric field. A positive charge moving in the direction of the electric field contributes equally to the current as a negative charge moving in the opposite direction. There does not have to be a net displacement of charge, from left to right say, to have an electric current. There is no need for a return path.

There is no fundamental need to return all charges to a common dump either. One has to be careful not to produce intense electric fields that break the stability of the material circuits, but beyond that, there is no need to return all charges to a big reservoir like the earth. For portable devices this is a good thing, otherwise they would be impossible to construct. To perform all the tasks required, it is enough to have either real dipoles in material substances, or virtual dipoles in the electromagnetic vacuum. Once the function has been satisfied, the device goes back to the state it had when the process started. Circuits according to the invention have one or more of the following attributes: circulation/symmetry breaking/dipoles; difference of time constant between charge and discharge; AC to DC rectification; tunable load to resonant frequency; frequency/voltage dependence; series inductance; series capacitance; and, an open system harnessing electromagnetic field energy.

SUMMARY OF THE INVENTION

According to one broad aspect of the invention a lighting system is provided having one or more LED circuits. Each LED circuit has at least two diodes connected to each other in opposing parallel relation, wherein at least one of which such diodes is an LED. As used throughout the application, the term diode may mean any type of diode capable of allowing current to pass in a single direction, including but not limited to, a standard diode, a schottky diode, a zener diode, and a current limiting diode. A driver is connected to the one or more LED circuits, the driver providing an AC voltage and current to the one or more LED circuits. The driver and the LED circuits form a driven circuit. The driver and the LED circuits are also configured such that LED circuits may be added to or subtracted (intentionally or by component failure) from the driven circuit:

- (a) without significantly affecting the pre-determined desired output range of light from any individual LED; and,
- (b) without the need to: (i) change the value of any discrete component; or, (ii) to add or subtract any discrete components, of any of the pre-existing driven circuit components which remain after the change.

In another embodiment of the invention at least one capacitor is connected to and part of each LED circuit. In yet another embodiment, at least one resistor is connected to and is part of each opposing parallel LED circuit noted above. The resistor is connected in series with the at least one capacitor.

According to another aspect of the invention an LED circuit (sometimes referred to as an "AC LED") can comprise two opposing parallel LEDs, an opposing parallel LED string or an opposing parallel LED matrix. These opposing parallel LEDs may have a capacitor in series connected to at least one junction of the connected opposing parallel configurations within a single chip, a single package, an assembly or a module.

When a real capacitor is connected in series in one or more lines between an LED and an AC power source, there is a displacement current through that capacity of magnitude: $I=2\pi CV$. The capacitor in the LED circuits of the invention regulates the amount of current and forward voltage delivered to the one or more opposing parallel LEDs

US 10,687,400 B2

5

based on the voltage and frequency provided by the AC driver. Based on the number of LEDs in the LED circuit the opposing parallel connections provide two or more junctions to which at least one series capacitor may be connected in series of at least one power connection lead. In some embodiments, LED circuits may also use a series resistor in addition to the capacitor providing an "RC" resistor capacitor network for certain LED circuit driver coupling that does not provide protection against surge currents to the LED circuits.

According to another aspect of the invention an LED circuit may comprise a single LED or a series string of diodes and/or LEDs connected to a full bridge rectifier capable of rectifying a provided AC voltage and current for use by the series string of diodes and/or LEDs. The rectifier may be formed as part of the LED circuit, or may be formed separately, having leads provided on both the output of the driver and the input of the LED circuit to allow the LED circuit to connect directly to the driver. In order to protect the LED circuit from voltage spikes a capacitor may be connected across the inputs of the bridge rectifier. The capacitor may also be used for smoothing the AC waveform to reduce ripple. A capacitor may likewise be connected between one rectifier input and the AC voltage and current source in order to limit the DC current flow to protect the LEDs. The bridge diode and LED circuit may be packaged separate or together, and may be configured within a single chip or two chips, a single package or two packages, an assembly, or a module.

According to another aspect of the invention, a single bridge rectifier may be used to drive parallel LEDs or series strings of diodes and/or LEDs. Alternatively, it is contemplated by the invention that each LED circuit requiring a bridge rectifier to utilize both the high and low phases of an AC power wave may include its own full bridge rectifier integrated or otherwise connected thereto. In embodiments where each LED circuit includes its own rectifier, additional LED circuits may be added in parallel across an AC voltage and current source to any existing LED circuits without concern of connecting to any existing bridge rectifiers or, where used, capacitors. Providing each LED circuit with its own bridge rectifier has the further advantage of scaling capacitors included in the circuit for voltage protection and/or current limiting to be matched to a particular LED or string of diodes and/or LEDs.

It should be noted that "package" or "packaged" is defined herein as an integrated unit meant to be used as a discrete component in either of the manufacture, assembly, installation, or modification of an LED lighting device or system. Such a package includes LED's of desired characteristics with capacitors and or resistors (when used) sized relative to the specifications of the chosen LED's to which they will be connected in series and with respect to a predetermined AC voltage and frequency.

Preferred embodiments of a package may include an insulating substrate whereon the LEDs, capacitors and/or resistors are formed or mounted. In such preferred embodiments of a package, the substrate will include electrodes or leads for uniform connection of the package to a device or system associated with an AC driver or power source or any individually packaged rectifiers used to rectify AC voltage and current. The electrodes, leads, and uniform connection may include any currently known means including mechanical fit, and/or soldering. The substrate may be such as sapphire, silicon carbide, gallium nitride, ceramics, printed circuit board material, or other materials for hosting circuit components.

6

A package in certain applications may preferably also include a heat sink, a reflective material, a lens for directing light, phosphor, nano-crystals or other light changing or enhancing substances. In sum, according to one aspect of the invention, the LED circuits and AC drivers of the present invention permit pre-packaging of the LED portion of a lighting system to be used with standardized drivers (and when necessary full wave rectifiers) of known specified voltage and frequency output. Such packages can be of varied make up and can be combined with each other to create desired systems given the scalable and compatible arrangements possible with, and resulting from, the invention.

According to one aspect of the invention, AC driven LED circuits (or "driven circuits") permit or enable lighting systems where LED circuits may be added to or subtracted (either by choice or by way of a failure of a diode) from the driven circuit without significantly affecting the pre-determined desired output range of light from any individual LED and, without the need to: (i) change the value of any discrete component; or, (ii) to add or subtract any discrete components, of any of the pre-existing driven circuit components which remain after the change. During design of a lighting system, one attribute of the LEDs chosen will be the amount of light provided during operation. In this context, it should be understood that depending on the operating parameters of the driver chosen, the stability or range of the voltage and frequency of the driver will vary from the nominal specification based upon various factors including but not limited to, the addition or subtraction of the LED circuits to which it becomes connected or disconnected. Accordingly, as sometimes referred to herein, drivers according to the invention are described as providing "relatively constant" or "fixed" voltage and frequency. The extent of this relative range may be considered in light of the acceptable range of light output desired from the resulting circuit at the before, during, or after a change has been made to the lighting system as a whole. Thus it will be expected that a pre-determined range of desired light output will be determined within which the driven LED circuits of the invention will perform whether or not additional or different LED circuits have been added or taken out of the driven circuit as a whole or whether additional or different LED circuits have been added proximate any existing LED circuits or positioned remotely.

According to another aspect of the invention an LED circuit may be at least one pre-packaged LED and one pre-packaged diode connected together opposing parallel of each other, two opposing parallel pre-packaged LEDs, an opposing parallel LED string of pre-packaged LEDs, an opposing parallel LED matrix of pre-packaged LEDs optionally having a capacitor in series of at least one junction of the connected LED circuits. It is contemplated that the LED circuit may also be at least one of a single LED or series string of diodes and/or LEDs having a bridge rectifier connected across the the single LED or string of diodes. In embodiments where a series string of diodes and/or LEDs and a rectifier is utilized, each LED may likewise be pre-packaged. The rectifier may optionally having a capacitor connected across the rectifier inputs and/or a capacitor connected between to an input of the rectifier for connection between the rectifier and a AC voltage and current source. In either embodiment, utilizing an LED circuit capacitor may allow for direct coupling of at least one LED circuit to the LED driver without additional series components such as capacitors and/or inductors between the LED circuit driver and the LED circuits. The LED circuit

US 10,687,400 B2

7

driver provides a relatively fixed voltage and relatively fixed frequency AC output even with changes to the load using feedback AC voltage regulator circuitry. The LED circuit's may be directly coupled and scaled in quantity to the LED circuit driver without affecting the other LED circuit's lumen output as long as the LED circuit driver maintains a relatively fixed voltage and relatively fixed frequency AC output.

According to an aspect of the invention, an LED circuit driver provides a relatively fixed voltage and relatively fixed frequency AC output such as mains power sources. The LED circuit driver output voltage and frequency delivered to the LED circuit may be higher than, lower than, or equal to mains power voltage and frequencies by using an LED circuit inverter driver. The LED circuit inverter driver providing higher frequencies is preferable for LED circuits that are integrated into small form LED packages that include integrated capacitors or resistor capacitor "RC" networks. The LED circuit inverter driver has feedback circuitry such as a resistor divider network or other means allowing it to sense changes to the load and re-adjust the frequency and/or voltage output of the LED circuit driver to a desired relatively fixed value. The LED circuit driver may also provide a soft-start feature that reduces or eliminates any surge current from being delivered to the LED circuit when the LED circuit driver is turned on. Higher frequency and lower voltage LED circuit inverter drivers are preferred enabling smaller package designs of LED circuits as the capacitor at higher frequencies would be reduced in size making it easier to integrate into a single LED circuit chip, package, assembly or module.

According to the invention LED circuits may have a resistor capacitor ("RC") network connected together in series or separate from the the LED circuits. The maximum resistor value needed is only that value of resistance needed to protect the one or more LEDs within the LED circuit from surge currents that may be delivered by LED circuit drivers that do not provide soft start or other anti surge current features. Direct mains power coupling would require RC network type LED circuits as the mains power source delivers surge currents when directly coupled to an LED circuit.

The higher frequency LED circuit inverter driver may be a halogen or high intensity discharge (HID) lamp type driver with design modifications for providing a relatively fixed voltage and relatively fixed frequency output as the LED circuit load changes. Meaning if the LED circuit inverter driver is designed to have an output voltage of 12V at a frequency of 50 Khz the LED circuit driver would provide this output as a relatively constant output to a load having one or more than one LED circuits up to the wattage limit of the LED circuit driver even if LED circuits were added to or removed from the output of the LED circuit driver.

The higher frequency inverter having a relatively fixed voltage and relatively fixed frequency output allows for smaller components to be used and provides a known output providing a standard reference High Frequency LED circuit driver enabling LED circuits to be manufactured in volume in existing or reasonably similar LED package sizes with integrated capacitors or RC networks based on the number of LEDs desired in the LED circuit package.

Patent publication number 20030122502 entitled Light Emitting Diode driver (Clauberg and Erhardt) does not disclose the use of a high frequency inverter driver having a means or keeping a relatively fixed voltage and relatively frequency in response to changes in the load. According to the present invention described herein, by not having addi-

8

tional components such as an inductor or capacitor in series between the LED circuit and the LED circuit driver one LED circuit at a time may be added to or removed from the LED circuit driver output without having to change any components, the LED circuit driver or make adjustments to the LED circuit driver. Additionally, according to this invention the lumen output of the existing LED circuits stays relatively constant due to the self-regulating nature of each individual LED circuit when driven with the relatively fixed frequency and voltage of the LED circuit driver. This level of scalability, single chip LED circuit packaging and standardization is not possible with the prior art using an inductor in series between the LEDs or other components due to the voltage or current increase or drop across the inductors and capacitors in response to changes in the load.

Prior art for single chip LED circuits, for example those disclosed in WO2004023568 and JP2004006582 do not provide a way to reduce the number of LEDs within the chip below the total forward voltage drop requirements of the source. The present invention however, enables an LED circuit to be made with any number of LEDs within a single chip, package or module by using, where desired, transformers, capacitors, or RC networks to reduce the number of LEDs needed to as few as one single LED. Improved reliability, integration, product and system scalability and solid state lighting design simplicity may be realized with LED circuits and the LED circuit drivers. Individual LED circuits being the same or different colors, each requiring different forward voltages and currents may be driven from a single source LED circuit driver. Each individual LED circuit can self-regulate current by matching the capacitor or RC network value of the LED circuit to the known relatively fixed voltage and frequency of the LED circuit driver whether the LED circuit driver is a mains power source, a high frequency LED circuit driver or other LED circuit driver capable of providing a relatively fixed voltage and relatively fixed frequency output.

When a real capacitor is connected in series in one or more lines between an LED and an AC power source, there is a displacement current through that capacity of magnitude: $I=2\pi fCV$. This means that one can predetermine the amount of current to be delivered through a capacitance based upon a known voltage and frequency of an AC source, allowing for each LED circuit containing a series capacitor to have the specific or ideal current required to provide the desired amount of light from the LED circuit.

According to other aspects of the invention, the LED circuit driver may be coupled to a dimmer switch that regulates voltage or frequency or may have integrated circuitry that allows for adjustability of the otherwise relatively fixed voltage and/or relatively fixed frequency output of the LED circuit driver. The LED circuits get brighter as the voltage and/or frequency of the LED circuit driver output is increased to the LED circuits.

One form of the invention is at least one LED and one diode connected together opposing parallel of each other, two opposing parallel LEDs, an opposing parallel LED string and/or opposing parallel LED matrix having a capacitor in series of at least one connected junction of the connected opposing parallel LED configurations within a single chip, a single package, an assembly or a module. When desired, the LED circuit with capacitor may be placed on an insulating substrates such as but not necessarily ceramic or sapphire and/or within various LED package sizes; materials and designs based of product specifications or assembled on printed circuit board material. Any integrated LED circuit capacitors should be scaled to a prede-

US 10,687,400 B2

9

terminated value enabling the LED circuit to self-regulate a reasonably constant and specific current when coupled to an LED circuit driver that provides a relatively fixed voltage and frequency output. Utilized LED circuit capacitors may be of a value needed to provide the typical operating voltage and current of the LED circuit when designed for coupling to a specific LED circuit driver.

Another form of the invention is an LED circuit comprising at least one LED and one diode connected together opposing parallel of each other, two opposing parallel LEDs, an opposing parallel LED string and/or opposing parallel LED matrix having a series resistor capacitor ("RC") network connected together in series or independently in series between at least one connected junction of the opposing parallel LEDs and the respective power connection of the LED circuit. When desired, the opposing parallel LEDs and RC network may be placed on an insulating substrate such as but not necessarily ceramic or sapphire and/or within various LED package sizes; materials and designs based of product specifications or assembled on printed circuit board material. The LED circuit RC network may be of a value needed to provide the typical operating voltage and current of the LED circuit when designed for coupling to a specific LED circuit driver.

Another form of the invention is an LED circuit comprising a matrix of two opposing parallel LEDs connected together in parallel with every two opposing parallel LEDs having an individual capacitor in series to the power source connection if desired. The entire parallel array of opposing parallel LED circuits, including capacitors when used, may be placed on an insulating substrate such as but not necessarily ceramic or sapphire and/or within various LED package sizes; materials and designs based of product specifications or assembled on printed circuit board material. The opposing parallel matrix of LED circuits integrated in the LED circuit package may be RC network type LED circuits.

Another form of the invention is an LED circuit comprising a matrix of opposing parallel LEDs connected together in parallel with every set of opposing parallel LEDs having an individual RC network in series to the power connection lead if desired.

Another form of the invention is an LED circuit comprising a matrix of opposing parallel LEDs connected together in parallel, a capacitor connected in series to at least one side of the line going to the matrix of opposing parallel LEDs with every set of opposing parallel LEDs having an individual resistor in series to the power connection if desired.

Yet another form of the invention is an LED circuit comprising opposing parallel series strings of LEDs connected together and driven direct with a high frequency AC voltage equal to or less than to total series voltage drop of the opposing parallel series strings of LEDs within the LED circuit.

Yet another form of the invention is a LED circuit comprising a single LED or a series string of diodes and/or LEDs and a bridge rectifier connected across the LED or string of diodes and/or LEDs. The rectifier may optionally include a capacitor connected across the inputs of the rectifier. The rectifier may additionally, or alternatively, optionally include a capacitor connected in series with one input, the capacitor being capable of connecting the rectifier input to an AC voltage and current source.

Yet another form of the invention is a LED circuit comprising a single LEDs or a series strings of diodes and/or LEDs connected in parallel across the output of a bridge rectifier. The rectifier may optionally include a capacitor connected across the inputs of the rectifier. The rectifier may

10

additionally, or alternatively, optionally include a capacitor connected in series with one input, the capacitor being capable of connecting the rectifier input to an AC voltage and current source.

Another form of the invention comprises a method of driving LED circuits direct from an AC power source ("LED circuit driver") having a relatively fixed voltage and relatively fixed frequency. The LED circuit driver may be a mains power source, the output of a transformer, a generator or an inverter driver that provides a relatively fixed voltage and relatively fixed frequency as the load changes and may be a higher or lower frequency than the frequencies of mains power sources. The LED circuit driver provides a relatively fixed voltage and relatively fixed frequency output even when one or more LED circuits are added to or removed from the output of the LED circuit driver. Higher frequency inverters with lower output voltages are used as one LED circuit driver in order to reduce component size and simplify manufacturing and standardization of LED circuits through the availability of higher frequency LED circuit drivers. The LED circuit driver may also include circuitry that reduces or eliminates surge current offering a soft-start feature by using MOSFET transistors, IGBT transistors or other electronic means. The LED circuit driver may also be pulsed outputs at a higher or lower frequency than the primary frequency.

Another form of the invention is an LED lighting system comprising an LED circuit array having a plurality of different LED circuits each drawing the same or different currents, each having the same or different forward operating voltages, and each delivering the same or different lumen outputs that may be the same or different colors and an LED circuit driver coupled to the LED circuit array. The LED circuit driver delivering a relatively fixed frequency and voltage output allows for mixing and matching of LED circuits requiring different forward voltages and drive currents. The LED circuits may be connected to the output of an LED circuit driver in parallel one LED circuit at a time within the limit of the wattage rating of the LED circuit driver with no need to change or adjust the LED circuit driver as would typically be required with DC drivers and LEDs when increasing or reducing the load with LEDs and other components. Never having to go back to the power source allows for more efficient integration and scalability of lighting systems designed with LED circuits and allows for a single driver to independently provide power to multiple independently controlled LED circuits in the system. Introducing an inductor and/or an additional capacitor such as the impedance circuit described in prior art between the LED circuit drive source and the LED circuits would require changes to the driver or components and prohibit scalability, standardization and mass production of AC-LEDs with integrated capacitors or RC networks.

With the LED circuit driver providing a known relatively constant AC voltage and frequency, mass production of various LED circuits with specific capacitor or RC network values would deliver 20 mA, 150 mA or 350 mA or any other desired current to the LED circuit based on the output of the specified LED circuit driver. The relatively fixed voltage and frequency allows for standardization of LED circuits through the standardization of LED circuit drivers.

In another aspect, a transistor is coupled to at least one power connection of the LED circuit or built into the LED circuit package in series between the power connection lead and the LED circuit with the transistor being operable to control (e.g., varying or diverting) the flow of the alternating current through the LED circuit through a capacitance within the transistor.

US 10,687,400 B2

11

The foregoing forms as well as other forms, features and advantages of the present invention will become further apparent from the following detailed description of the presently preferred embodiments, read in conjunction with the accompanying drawings. The detailed description and drawings are merely illustrative of the present invention rather than limiting, the scope of the present invention being defined by the appended claims and equivalents thereof.

BRIEF DESCRIPTION OF THE DRAWINGS

FIG. 1 shows a schematic view of a preferred embodiment of the invention.

FIG. 2 shows a schematic view of a preferred embodiment of the invention.

FIG. 3 shows a schematic view of a preferred embodiment of the invention.

FIG. 4 shows a schematic view of a preferred embodiment of the invention.

FIG. 5 shows a schematic view of a preferred embodiment of the invention.

FIG. 6 shows a schematic view of a preferred embodiment of the invention.

FIG. 7 shows a schematic view of a preferred embodiment of the invention.

FIG. 8 shows a schematic view of a preferred embodiment of the invention.

FIG. 9 shows a schematic view of a preferred embodiment of the invention.

FIG. 10 shows a schematic view of a preferred embodiment of the invention.

FIG. 11 shows a schematic view of a preferred embodiment of the invention.

FIG. 12 shows a schematic view of a preferred embodiment of the invention.

FIG. 13 shows a schematic view of a preferred embodiment of the invention.

FIG. 14 shows a schematic view of a preferred embodiment of the invention.

FIG. 15 shows a schematic view of a preferred embodiment of the present invention.

FIG. 16 shows a schematic view of a preferred embodiment of the present invention.

FIG. 17 shows a schematic view of a preferred embodiment of the present invention.

FIG. 18 shows a schematic view of a preferred embodiment of the present invention.

FIG. 19 shows a schematic view of a preferred embodiment of the invention.

FIG. 20 shows a schematic view of a preferred embodiment of the invention.

FIG. 21 shows a schematic view of a preferred embodiment of the invention.

FIG. 22 shows a schematic view of a preferred embodiment of the invention.

FIG. 23 shows a schematic view of a preferred embodiment of the invention.

FIG. 24 shows a schematic view of a preferred embodiment of the present invention.

FIG. 25 shows a schematic view of a preferred embodiment of the present invention.

FIG. 26 shows a schematic view of a preferred embodiment of the present invention.

FIG. 27 shows a schematic view of a preferred embodiment of the present invention.

FIG. 28 shows a schematic view of a preferred embodiment of the present invention.

12

FIG. 29 shows a schematic view of a preferred embodiment of the invention.

FIG. 30A shows a schematic view of a preferred embodiment of the invention.

FIG. 30B shows a schematic view of a preferred embodiment of the invention.

FIG. 30C shows a schematic view of a preferred embodiment of the invention.

FIG. 30D shows a schematic view of a preferred embodiment of the invention.

FIG. 30E shows a schematic view of a preferred embodiment of the invention.

FIG. 31 shows a schematic view of a preferred embodiment of the invention.

FIG. 32 shows a schematic view of a preferred embodiment of the invention.

FIG. 33 shows a schematic view of a preferred embodiment of the invention.

FIG. 34 shows a schematic view of a preferred embodiment of the invention.

FIG. 35 shows a schematic view of a preferred embodiment of the invention.

FIG. 36 shows a schematic view of a preferred embodiment of the invention.

FIG. 37 shows a schematic view of a preferred embodiment of the invention.

FIG. 38 shows a schematic view of a preferred embodiment of the invention.

FIG. 39 shows a schematic view of a preferred embodiment of the invention.

FIG. 40 shows a schematic view of a preferred embodiment of the invention.

FIG. 41 shows a schematic view of a preferred embodiment of the invention.

FIG. 42 shows a schematic view of a preferred embodiment of the invention.

FIG. 43 shows a schematic view of a preferred embodiment of the invention.

FIG. 44 shows a schematic view of a preferred embodiment of the invention.

FIG. 45 shows a schematic view of a preferred embodiment of the invention.

FIG. 46 shows a schematic view of a preferred embodiment of the invention.

FIG. 47 shows a schematic view of a preferred embodiment of the invention.

FIG. 48 shows a schematic view of a preferred embodiment of the invention.

FIG. 49 shows a schematic view of a preferred embodiment of the invention.

FIG. 50 shows a schematic view of a preferred embodiment of the invention.

FIG. 51 shows a schematic view of a preferred embodiment of the invention.

FIG. 52 shows a schematic view of a preferred embodiment of the invention.

FIG. 53 shows a schematic view of a preferred embodiment of the invention.

FIG. 54 shows a schematic view of a preferred embodiment of the invention.

FIG. 55 shows a schematic view of a preferred embodiment of the invention.

FIG. 56 shows a schematic view of a preferred embodiment of the invention.

FIG. 57 shows a schematic view of a preferred embodiment of the invention.

US 10,687,400 B2

13

FIG. 58 shows a schematic view of a preferred embodiment of the invention.

FIG. 59 shows a schematic view of a preferred embodiment of the invention.

FIG. 60 shows a schematic view of a preferred embodiment of the invention.

FIG. 61 shows a schematic view of a preferred embodiment of the invention.

FIG. 62 shows a schematic view of a preferred embodiment of the invention.

FIG. 63 shows a schematic view of a preferred embodiment of the invention.

FIG. 64 shows a schematic view of a preferred embodiment of the invention.

FIG. 65 shows a schematic view of a preferred embodiment of the invention.

FIG. 66 shows a schematic view of a preferred embodiment of the invention.

FIG. 67 shows a schematic view of a preferred embodiment of the invention.

FIG. 68 shows a schematic view of a preferred embodiment of the invention.

DETAILED DESCRIPTION OF PREFERRED EMBODIMENTS

While this invention is susceptible to embodiments in many different forms, there is described in detail herein, preferred embodiments of the invention with the understanding that the present disclosures are to be considered as exemplifications of the principles of the invention and are not intended to limit the broad aspects of the invention to the embodiments illustrated.

The present invention is directed to an LED light emitting device and LED light system capable of operating during both the positive and negative phase of an AC power supply. In order to operate during both phases provided by an AC power, as is shown herein, the circuit must allow current to flow during both the positive and negative phases and LED light emitting devices may be configured such that at least one LED is capable of emitting light during one or both of the positive or negative phases. In order to accomplish this, the LED circuit itself may be configured so as to allow current to pass during both phases, or the device may include a bridge rectifier to rectify AC power for use by single LEDs, series strings of LEDs, and parallel series strings of LEDs. Rectification may be accomplished within the light emitting device, or prior to any power being provided to the same. Once integrated into a light system, the present invention further contemplates a driver having the ability to provide a substantially constant voltage at a substantially constant frequency, and that the driver be configured in a manner which will allow LED light emitting devices to be added to or subtracted from the system, regardless of configuration, without having to add, subtract, or change the values of discrete circuit components and without affecting the light output of any individual LED.

FIG. 1 discloses a schematic diagram of a light emitting device 10 for an AC driver according to one embodiment of the invention. The device 10 includes a first LED 12 connected to a second LED 14 in opposing parallel configuration, a capacitor 16 connected in series between a first junction 18 of the two opposing parallel LEDs, a first power connection 20 connected to the two opposing parallel LEDs, and a second power connection 22 connected to a second junction 24 of the two opposing parallel connected LEDs. A diode may be used in place of LED 12 or LED 14.

14

FIG. 2 discloses a schematic diagram of a light emitting device 26 for an LED circuit driver according to an embodiment of the invention. The device 26 includes the device 10 as disclosed in FIG. 1 mounted on an insulating substrate 28 such as, but not necessarily, ceramic or sapphire, and integrated into an LED package 30 that may be various LED package sizes; materials and designs based of product specifications or on printed circuit board material. The device 26 provides power connection leads 32 and may have a first or additional lens 34 that may be made of a plastic, polymer or other material used for light dispersion and the lens may be coated or doped with a phosphor or nano-particle that would produce a change in the color or quality of light emitted from the device 10 through the lens 34.

FIG. 3 discloses a schematic diagram of a device 36 having a schematic diagram of the embodiment shown as light emitting device 26 driven directly by an AC driver 38 that is connected to the power connections 32 of the device 26 without any additional components in series between the AC driver 38 and the device 26 such as a capacitor, inductor or resistor. The AC driver 38 provides a relatively constant AC voltage and frequency output to the device 26 no matter what the total load of the device 26 may be, or the number of devices 26 added or subtracted as long as the load does not exceed the wattage limitation of the AC driver 38. The AC driver 38 may be a generator, a mains power source, or an inverter capable of providing a relatively fixed voltage and relatively fixed frequency output to different size loads. The AC driver may provide a low or high voltage and a low or high frequency to the device 26 according to the invention as long as the capacitor 16 is the proper value for the desired operation of the device 26.

FIG. 4 discloses a schematic diagram of a light emitting device 40 for coupling to an LED circuit driver according to an embodiment of the invention. The device 40 includes a first LED 42 connected to a second LED 44 in opposing parallel configuration. A capacitor 46 is connected in series between a first junction 48 of the two opposing parallel LEDs and a first power connection 50. A resistor 52 is connected in series between a second junction 54 of the two opposing parallel LEDs and a second power connection 56. A diode may be used in place of LED 42 or LED 44 and the resistor 52 may be put in series on either end of the capacitor 46 as an alternate location.

FIG. 5 discloses a schematic diagram of a light emitting device 58 for LED circuit drivers according to an embodiment of the invention. The device 58 includes the device 40 as disclosed in FIG. 4 integrated into a package as disclosed in the device 26 in FIG. 2. The device 58 provides power connection leads for connecting to an AC driver 38 as disclosed in FIG. 3.

FIG. 6 discloses a diagram of a light emitting device 64 for coupling to an LED circuit driver according to an embodiment of the invention. The device 64 includes a first series string of LEDs 66 connected to a second series string of LEDs 68 in opposing parallel configuration, a capacitor 70 connected in series between a first junction 72 of the opposing parallel series string of LEDs and a first power connection 74, and a second power connection 76 connected to a second junction 78 of the opposing parallel series string of LEDs. A diode may be used in place of one or more LEDs 66 and one or more of LEDs 68 and the LEDs 66 and 68 are integrated into a package 80 as described in the package 30 disclosed in FIG. 2 along with capacitor 70.

FIG. 7 discloses a diagram of a light emitting device 82 for AC drive according to an embodiment of the invention. The device 82 includes a first series string of LEDs 84

US 10,687,400 B2

15

connected to a second series string of LEDs **86** in opposing parallel configuration, a capacitor **88** connected in series between a first junction **90** of the opposing parallel series string of LEDs and a first power connection **92**, and a resistor **94** connected in series between a second junction **96** of the opposing parallel series string of LEDs and a second power connection **98**. A diode may be used in place of one or more LEDs **84** and one or more of LEDs **86** and the LEDs **84** and **86** are integrated into a package **100** as described in the package **30** disclosed in FIG. 2 along with capacitor **88** and resistor **94**. The resistor **94** may be put in series on either end of the capacitor **88** as an alternate location.

FIG. 8 discloses a diagram of a light emitting device **102** according to an embodiment of the invention. The device **102** includes a first series string of LEDs **104** connected to a second series string of LEDs **106** in opposing parallel configuration. A first power connection **108** is connected to a first junction **110** of the opposing parallel series string of LEDs and a second power connection **112** is connected to a second junction **114** of the opposing parallel series string of LEDs. A diode may be used in place of one or more LEDs **104** and one or more of LEDs **106** and the LEDs **104** and **106** are integrated into a package **118** as described in the package **30** disclosed in FIG. 2.

FIG. 9 discloses a circuit diagram of a light emitting device **120** according to an embodiment of the invention. The device **120** is similar to the device disclosed in FIG. 5 and includes a second series resistor **122** that can be placed in series on either side of the first capacitor **46**.

FIG. 10 discloses a diagram of a light emitting device **124** according to an embodiment of the invention. The device **124** is similar to the device disclosed in FIG. 2 and includes a second series capacitor **126** connected in series between the junction **128** of the opposing parallel LEDs and a power connection **130**.

FIG. 11 discloses a diagram of a light emitting device **130** according to an embodiment of the invention. The device **130** has a matrix of individual light emitting devices **10** as described in FIG. 1 integrated into a package **132** similar to package **30** as described in FIG. 2.

FIG. 12 discloses a diagram of a light emitting device **134** according to an embodiment of the invention. The device **134** has a matrix of individual light emitting devices **40** as described in FIG. 4 integrated into a package **136** similar to package **30** as described in FIG. 2.

FIG. 13 discloses a diagram of a light emitting device **138** according to an embodiment of the invention. The device **138** has a matrix of individual sets of 2 opposing parallel light emitting devices **140** with each set having an individual series resistor to connect to a first power connection **140** and a capacitor **146** connected in series between a second power connection and the matrix of devices **140**. The capacitor **146** may alternately be in series between the first power connection **144** and all resistors **142**. The matrix of devices **140**, resistors **142** and capacitor **146** are integrated into a package **150** similar to package **30** as described in FIG. 2.

FIG. 14 discloses a diagram of a light emitting device **152** according to an embodiment of the invention. The device **152** includes another version of a series opposing parallel LED matrix **154** and a capacitor **156** connected in series between a first junction **158** of the opposing parallel LED matrix **154** and a first power connection, and a second power connection **162** connected to a second junction **164** of the opposing parallel LED matrix. A first power connection **108** is connected to a first junction **110** of the opposing parallel series string of LEDs and a second power connection **112** is connected to a second junction **114** of the opposing parallel

16

series string of LEDs. A diode may be used in place of one or more LEDs **104** and one or more of LEDs **106** and the LEDs **104** and **106** are integrated into a package **118** as described in the package **30** disclosed in FIG. 2.

FIG. 15 discloses a schematic diagram of a light emitting device **300** according to an embodiment of the invention. Device **300** includes bridge rectifier circuit **302** having diodes **304a-304d** with at least one LED connected across the output of the rectifier circuit, shown as LED **306**. While inputs **308** and **310** of the bridge rectifier may be provided for direct connection to an AC power supply, it is contemplated by the invention that one input, shown as input **310**, may have a capacitor (shown as capacitor **312**) or a resistor (shown in FIG. 18 as resistor **313**) connected in series in order to control and limit the current passing through the at least one LED. Additionally, capacitor **314** may be connected across the rectifier inputs to protect against voltage spikes.

FIGS. 16 and 18 each disclose a schematic diagram of a light emitting device **316** and **332** for an LED circuit driver according to an embodiment of the invention. The device **316** includes the device **300** as disclosed in FIG. 15 (with additional LEDs **306** added in series) mounted on an insulating substrate **318** such as, but not necessarily, ceramic or sapphire, and forming an LED package **320** that may be various sizes; materials and designs based of product specifications or on printed circuit board material. As shown in FIG. 16, The device **316**, **332** provides power connection leads **322** and **323** and may have a first or additional lens that may be made of a plastic, polymer or other material used for light dispersion and the lens may be coated or doped with a phosphor or nano-particle that would produce a change in the color or quality of light emitted from device **300** through the lens. LED package **320** may include rectifier **302** to drive LEDs **306**. Rectifier **306** may be mounted on insulating substrate **318** along with any LEDs. As should be appreciated by those having ordinary skill in the art, it is contemplated by the invention that any diode or LED may be swapped for the other within the package so long as the package includes at least one LED to emit light when in operation. Any capacitors **312**, **314** or resistors **313** included in the light emitting devices may like wise be mounted on substrate **318** and included in LED package **320**.

Rather than be packaged together and mounted on a single substrate, and no matter whether the LEDs and diodes are integrated into a single package or are discrete individual LEDs and/or diodes wire-bonded together, as disclosed in FIG. 17 rectifier **302** may be discretely packaged separate from any discrete LED packages **324** where discrete LED package **324** includes one LED **306** or multiple LEDs connected in series or parallel. Rectifier **302** may be packaged into rectifier package **326** for plug and use into a light system, or alternatively may be included as part of a driver used to drive the series LEDs. When packaged separate, package **326** may be provided with input power connections **328** and **329** which to connect the inputs of the rectifier to an AC power supply. In order to connect to one (or more) single or series LEDs and provide power thereto, package **326** may also be provided with output power connections **330** and **331** which may connect to LED package inputs **334** and **335**. Any capacitors **312**, **314** or resistors **313** included in the light emitting devices may like wise be mounted on substrate **316** and included in rectifier package **326**.

Regardless of whether rectifier **302** and LEDs **306** are integrated or mounted in a single package or are discretely packaged and connected, in order to drop higher voltages any number of LEDs may be connected in series or parallel

US 10,687,400 B2

17

in a device to match a desired voltage and light output. For example, in a lighting device that is run off of a 120 V source and contains LEDs having a forward operating voltage of 3V each connected to a bridge rectifier having diodes also having a forward operating voltage of 3V each, approximately 38 LEDs may be placed in series to drop the required voltage.

FIG. 19 discloses an embodiment of an LED lighting device encapsulated in a housing. As shown in FIG. 19, LED device 336 may include a housing 338 encapsulating at least one bridge rectifier 340, at least one LED circuit 342 connected across the output of the bridge rectifier. Device 334 includes first power connection lead connected 344 to a first input of the rectifier 346 and a second power connection lead 348 connected to a second input of the rectifier 350. At least a portion of each power connection is contained within the housing while at least a portion of each power connection extends beyond the housing to allow device 336 to connect to an AC power source. Rectifier 340 and LED circuit 342 may be connected, assembled, and/or packaged within housing 336 using any of the methods described in conjunction with FIGS. 15-18 or any other means known in the art. It should be appreciated by those having ordinary skill in the art that the devices and packages described in FIGS. 2, 3, and 5-14 may likewise incorporate a housing to encapsulate any device and/or package therein.

FIG. 20 discloses a schematic diagram of a lighting system 168 according to an embodiment of the invention. The device 168 includes a plurality of devices 26 as described in FIG. 2 connected to a high frequency inverter AC drive Method 170 as described in FIG. 3 which in this example provides a relatively constant 12V AC source at a relatively constant frequency of 50Khz to the devices 26. Each or some of the devices 26 may have integrated capacitors 172 of equal or different values enabling the devices 26 to operate at different drive currents 174 from a single source AC drive Method.

FIG. 21 discloses a schematic diagram of a lighting system 176 according to an embodiment of the invention. The lighting system 176 includes a plurality of devices 178, 180 and 182 each able to have operate at different currents and lumens output while connected directly to the transformer 184 output of a fixed high frequency AC drive Method 186.

Any of the aforementioned AC drive methods may likewise be used with the devices embodied in FIGS. 15-19.

For example, FIG. 22 discloses a schematic diagram of a lighting system 400 according to an embodiment of the invention. System 400 includes a plurality of devices 316, 332 as described in FIGS. 16 and 18 connected to a high frequency inverter AC drive Method 170 similar to that described in FIGS. 3 and 20 which provides a relatively constant 12V AC source at a relatively constant frequency of 50 Khz to the devices 316, 332. Each or some of the devices 316, 332 may have integrated capacitors 312, 314 and resistors 313 of equal or different values enabling the devices 300 to operate at different drive currents from a single source AC drive Method. As should be appreciated by those having ordinary skill in the art, while the example of 12V AC at 50 Khz is given herein, it is contemplated by the invention that any voltage at substantially any frequency may be provided by the driver by utilizing a proper transformer and/or inverter circuit.

Similarly, AC drive Method 186 may be utilized may be used with a single or plurality of devices 214 as disclosed in FIG. 23. As with the embodiment shown in FIG. 21, each

18

device 316, 332 may be connected directly to transformer 184 output to receive a substantially fixed frequency voltage.

FIG. 24 discloses an embodiment of the invention where AC drive Method 186 is provided to a rectifier and LED series strings are discretely packaged. As previously disclosed, rectifier 302 may be discretely packaged in a rectifier package 326, separate from both AC drive Method 186 (or alternatively AC drive Method 170) and discrete LED packages 324, or alternatively may be included in AC drive Method 186.

FIG. 25 discloses another schematic view diagram of a light emitting device 188 identical to the device 130 disclosed in FIG. 11 and integrated into a package 30 as described in FIG. 2 for an AC drive Method according to an embodiment of the invention. The device 188 includes the device 130 as disclosed in FIG. 11 mounted on an insulating substrate 28 such as but not necessarily ceramic or sapphire and integrated into an LED package 30 that may be various LED package sizes; materials and designs based of product specifications or on printed circuit board material. The device 188 provides power connection leads 190 and 192 and may have a first or additional lens 194 that may be made of a plastic, polymer or other material used for light dispersion and the lens may be coated or doped with a phosphor or nano-crystals that would produce a change in the color or quality of light emitted from the device 130 through the lens 194. The device 130 has a matrix of devices 10. The power connection opposite the capacitors 16 within the device 130 and part of each device 10 is connected to a power connection 196 that is connected to a solderable heat sinking material 198 and integrated into the package 30. The power connection 196 connected to the heat sink 198 may be of a heavier gauge within the device 130 or 188 than other conductors. The schematic view of the device 188 provides a side view of the package 30 and an overhead view of the device 130 in this FIG. 25.

FIG. 26 discloses another schematic view diagram of a light emitting device 198 similar to the device 188 described in FIG. 25 with a different light emitting device 200 identical to the device 136 disclosed in FIG. 12 and integrated into a package 30 as described in FIG. 2 for an AC drive Method according to an embodiment of the invention. The device 198 includes a reflective device integrated into the package 30 for optimized light dispersion. The light emitting device 200 may be facing down towards the reflector 202 and opposite direction of light output from the lens 194 if the reflector 202 is integrated into the package 30 properly for such a design.

FIG. 27 discloses another schematic view diagram of a light emitting device 500 similar to that shown in FIG. 24 according to an embodiment of the invention. The device 500 includes the devices 316, 332 similar to those disclosed in FIGS. 16 and 18, mounted on an insulating substrate 318 such as but not necessarily ceramic or sapphire and integrated into an LED package 320 that may be various LED package sizes; materials and designs based of product specifications or on printed circuit board material. The device 500 provides power connection leads 502 and 503 which connect to package power connect leads 322 and 323 and may have a first or additional lens 504 that may be made of a plastic, polymer or other material used for light dispersion and the lens may be coated or doped with a phosphor or nano-crystals that would produce a change in the color or quality of light emitted from the device through the lens 504. Power

US 10,687,400 B2

19

connection 322 may be connected to heat sink 506 and may be of a heavier gauge within the device than other conductors.

FIG. 28 discloses another schematic view diagram of a light emitting device 508 similar to that shown in FIG. 26. Device 508 is contemplated for use in embodiments where the rectifier is discretely packaged or included as part of AC drive Method 170 or 186. In device 508, power connection leads 510 and 511 connect to the outputs of rectifier 302 (not shown) to provide power to LED packages 324.

FIG. 29 shows a block diagram of an LED circuit driver 204 having a high frequency inverter 206 stage that provides a relatively constant voltage and relatively constant frequency output. The high frequency inverter 206 stage has an internal dual half bridge driver with an internal or external voltage controlled oscillator that can be set to a voltage that fixes the frequency. A resistor or center tapped series resistor diode network within the high frequency inverter 206 stage feeds back a voltage signal to the set terminal input of the oscillator. An AC regulator 208 senses changes to the load at the output lines 210 and 212 of the inverter 206 and feeds back a voltage signal to the inverter 208 in response changes in the load which makes adjustments accordingly to maintain a relatively constant voltage output with the relatively constant frequency output.

FIG. 30 shows a schematic diagram of an LED circuit driver 214 having a voltage source stage 216, a fixed/adjustable frequency stage 218, an AC voltage regulator and measurement stage 220, an AC level response control stage 222, an AC regulator output control stage 224 and a driver output stage 226.

FIG. 31 shows a schematic diagram of the voltage source stage 216 described in FIG. 20. The voltage source stage 216 provides universal AC mains inputs 228 that drive a diode bridge 230 used to deliver DC to the LED circuit driver system 214. Direct DC could eliminate the need for the universal AC input 228. Power factor correction means 232 may be integrated into the LED circuit driver 216 as part of the circuit. The voltage source stage 216 includes a low voltage source circuit 234 that may include more than one voltage and polarity.

FIG. 32 shows a schematic diagram of the fixed/adjustable frequency stage 218 as described in FIG. 20. The fixed/adjustable frequency stage 218 includes a bridge driver 236 that may include an integrated or external voltage controlled oscillator 238. The oscillator 238 has a set input pin 240 that sets the frequency of the oscillator to a fixed frequency through the use of a resistor or adjustable resistor 242 to ground. The adjustable resistor 242 allows for adjusting the fixed frequency to a different desired value through manual or digital control but keeps the frequency relatively constant based on the voltage at the set terminal 240.

FIG. 33 is a schematic diagram of the AC voltage regulator with voltage measurement stage 220 as described in FIG. 20. The AC voltage regulator with voltage measurement circuit 220 monitors the voltage at the driver output 226 as shown in FIG. 20 and sends a voltage level signal to the AC level response control stage 222 as shown in FIG. 20.

FIG. 34 is a schematic diagram of the AC level response control 228 stage. The AC level response control stage 228 receives a voltage level signal from the AC voltage regulator with voltage measurement circuit 220 as shown in FIG. 23 and drives the AC regulator output control stage 224 as shown in FIG. 20.

FIG. 35 is a schematic diagram of the AC regulator output control stage 230. The AC regulator output control stage 230 varies the resistance between the junction of the drive

20

transistors 232 and the transformer input pin 234 of the driver output 226 as shown in FIG. 26. The AC regulator output control stage 230 is a circuit or component such as but not necessarily a transistor, a voltage dependent resistor or a current dependent resistor circuit having a means of varying its resistance in response to the voltage or current delivered to it.

FIG. 36 is a schematic diagram of the driver output stage 226. The driver output stage 226 includes drive transistors 232 and the transformer 236 that delivers an AC voltage output 238 to LED circuits at a relatively constant voltage and frequency.

FIGS. 37 and 38 discloses a circuit 1104 to illustrate another aspect of the invention. Accordingly, an alternating electric field is provided to a first transmission conductor by a signal generator 1102 and a second transmission conductor is provided by an antenna 1108 (see FIG. 37) or wire 1124 (see FIG. 38) that is connected to a relatively less positive side 1114-1122 within the directional circuit 1110. A difference in DC potential between a relatively more positive side 1112 within the directional circuit, and relatively less positive side 1114-1122 is provided. Another aspect of the invention is sensing proximity with impedance changes within the directional circuits described herein (as it could be with any embodiment disclosed herein) by approaching any of the directional circuits or transmission conductors (also any of which are described herein), for example approaching 1108 (shown in FIG. 37) and/or 1124 (as shown in FIG. 38) with a conductive substance such as a person, including the touch of a person (human touch), or metallic material thereby changing the circulation of current flow within the directional circuit by changes in impedance through the capacitance of the conductive substance.

FIGS. 39, and 40-41 disclose another embodiment of the invention having a directional organic light emitting diode ("OLEO") circuit 1154 that includes a first diode D1 1156, a second diode D2 1158, and an OLED 1157. The first diode D1 1156 has an anode and the second diode D2 1158 has a cathode, which are commonly connected to a input transmission conductor 1160. The cathode of diode D1 1156 is connected to the relatively more positive side 1162 anode of an OLED 1157 while the anode of diode D2 1158 is connected to the relatively less positive side cathode 1164 of the OLED 1157 to form the loop circuit 1154 among the diodes D1, D2 and the OLED 1157. The directional OLEO circuit 1154 is a loop circuit which includes one or more circuit elements (e.g. diodes or OLEDs 1156, 1157 and 1158) causing the loop circuit to be asymmetric to current flow. Circuit element 1157 is an OLED. The directional OLEO circuit 1154 does not have a continuous conductive path to earth ground, or battery ground. The directional OLEO circuit 1154 develops a DC potential in response to an alternating electric field imposed on input 1160. The directional OLEO circuit 1154 is self referencing between a relatively high potential output and a relatively lower potential output. The directional OLEO circuit 1154 has a resistance, inductance and capacitance that is responsive to the voltage and frequency of the alternating electric field. The directional OLEO circuit 1154 has transmission conductors 1166, 1168 connected to the directional OLEO circuit 1154.

FIG. 40 discloses a circuit 1182 with the same embodiment of the invention shown in FIG. 39 (see FIG. 39) encasing the directional OLEO circuit 1154 within a package 1163.

FIG. 41 discloses a circuit 1184 with the same embodiment of the invention shown in FIG. 39 (see FIG. 39) with a second transmission conductor 1185 providing an input

US 10,687,400 B2

21

within the directional circuit **1184** at a point other than the input of the first transmission conductor input of **1160**. The transmission conductors **1160** and **1185** (or any transmission conductors described herein) can act as an antenna and cause the directional OLEO circuit **1184** to react to the proximity of conductive substances near the transmission conductors **1160** and **1185**. In preferred embodiments, the circuits disclosed in FIGS. **39-41** and **43** below may be connected to ground through capacitance at a point within the directional circuit such as transmission conductor **1185** (e.g. FIG. **41**). This ground connection seems to provide increased circulation current, as it is noted that the OLEDs get brighter for a given alternating electromagnetic source.

FIG. **42** discloses a circuit **1226** identical to circuit **1210** but that the circuit has a first transmission conductor **1228** and a second transmission conductor **1230**. Each transmission conductor **1228,230** can be driven with an alternating electric field and can cause the circuit **1226** to react to the proximity of a conductive substance that approaches the transmission conductors **1228** and **1230** with only one or both conductors being driven.

FIG. **43** discloses another embodiment of the invention having a directional organic light emitting diode (“OLEO”) circuit **1170** that includes a first OLEO **1172**, a second OLEO **1174**, and a third OLEO **1176**. The first OLEO **1172** has an anode and the third OLEO **1176** has a cathode, which are commonly connected to an input transmission conductor **1178** having AC signal source from a signal generator **1180**. The cathode of the first OLEO **1172** is connected to the anode of the second OLEO **1174** while the cathode of the second OLEO **1174** is connected to the anode of the third OLEO **1176** to form the loop circuit **1170** among the OLEDs 1, 2 and 3 (**1172-1176**). The directional OLEO circuit **1170** can be designed with more than 3 OLEDs.

FIG. **44** discloses a preferred circuit **2010** according to the invention. The circuit **2010** includes a first source for providing an alternating electric field. The source may be 120V or 240V line power, RF energy or the output of a standard AC signal generator such as generator **2012** of FIG. **44**. This generator **2012** may produce its signal with reference to ground as indicated in FIG. **44**. Circuit **2010** also discloses a directional circuit **2014** connected to the generator **2012** by a transmission conductor **2016**. According to the invention the conductor **2016** may be any form of conventional conductive path whether twisted wire bundles, single wires, etc. The point is that the transmission conductor **2016** provides a single transmission path to the directional circuit **2014**. Important to the invention is the fact that there is no conductive return path provided back from the directional circuit **2016** to the generator **2012**.

In the broad sense, the directional circuit **2014** is a loop circuit which includes one or more circuit elements causing the loop circuit to be asymmetric to current flow. Again it is important that the directional circuit **2014** has no continuous conductive path to earth ground, or a battery ground. As such, and as disclosed in FIG. **44** the directional circuit **2014** develops a DC potential across a load, such as resistor R1 in response to the alternating electric field. This DC potential is not referenced to ground but merely to the potential differences created by the circulation of current (see FIG. **45**) in the loop across the load (resistor R1 of FIG. **44**). Accordingly, the DC potential is self referencing. As far as the resistor R1 is concerned, circuit **2010** presents it with a relatively higher DC potential output at **2020** and a relatively lower potential output at **2022**.

FIG. **45** discloses circuit **2010** with the load represented as a generic load **2024** (rather than resistor R1) to show the

22

circulation path of current flow (indicated by the arrows) in any generic load circuit utilizing the DC potential of circuit **2010**.

FIGS. **44** and **45** disclose that the loads connected to the directional circuit **2014** do not have a continuous conductive path to earth ground or a battery ground. They also disclose that the directional circuit **2014** has circuit elements causing the directional circuit to be asymmetric to current flow. In the preferred embodiment disclosed, these circuit elements are diodes D1 and D2. However, it is contemplated that numerous other circuit elements could provide the same functionality, in particular, semiconductors with “pn” junctions; electrets, plasma, organic; or combinations thereof.

The circuit **2010** is preferably used for delivering power and sensing proximity. The circuit **2010** is also preferably useful in TTL logic applications as disclosed in FIG. **46** showing a standard TTL logic output circuit **2026** powered by circuit **2010**. In that application, the DC voltages necessary range from 0V to +/-5V.

FIGS. **44-46** each disclose that directional circuit **2014** includes first and second diodes D1 and D2, with D1 having an anode and diode D2 having a cathode which are commonly connected to the transmission conductor **2016**. The cathode of the first diode D1 is connected to the relatively more positive side of the load **2020** while the anode of the second diode is connected to the relatively less positive side load **2022** to form the directional loop circuit among the diodes and the load.

FIG. **47** discloses a circuit **2024** according to the invention having a standard AC signal generator **2026** and a directional circuit **2028** includes first and second light emitting diodes (LEDs), the first LED 1 has an anode and the second LED 2 has a cathode, which are commonly connected to the conductor **2030** from the generator **2026**. The cathode of LED 1 is connected to the relatively more positive voltage side **2032** of the load **2036** while the anode of LED 2 is connected to the relatively less positive side **2034** of the load **2036** to form the loop circuit **2028** among the LEDs 1 and 2. In this embodiment the load is configured to optimize the lumen produced by the directional circuit, for example the LEDs 1, 2 used to deliver power to the load **2036** which can be a third LED as shown in FIG. **48**.

FIG. **48** discloses a circuit **2038** according to the invention. In this embodiment, a generator **2040** produces an alternating electric field on transmission conductor **2040**. The conductor **2041** is connected to a directional circuit **2042** having circuit elements causing an asymmetrical response to the alternating field and current flow. In particular, circuit **2042** includes three LEDs 1, 2, 3, configured to provide circulation according to the direction of the arrows (see FIG. **48**). In this embodiment, all three LEDs 1-3 provide light as an output that can be considered as a load. This shows that relative nature of the positioning of elements in the various directional circuits disclosed herein according to the invention. If light is desired, then each of the diodes may be considered both loads and circuit elements which cause asymmetrical current flow. For example, FIG. **49** discloses the same circuit **2038** with only the substitution of LEDs 1 and 3 by diodes D1 and D2. In this circuit, optimization of the light emitted by LED 2 is of paramount concern, whereas the diodes 1, 2 provide directionality and a DC offset to the AC signal source as will be disclosed in more detail below. In preferred embodiments, the directional circuits, including directional circuit **2014**, disclosed herein throughout this invention may be connected to ground through capacitance **2039** at a point within the directional circuit other than the AC signal input point **40** as

US 10,687,400 B2

23

shown in FIG. 49. This ground connection seems to provide increased circulation current, as it is noted that the LEDs get brighter for a given alternating electromagnetic source. The capacitor 2039 may alternatively be placed on the other side of the AC line 2041. The capacitor is used to drop the voltage from the AC source.

FIG. 50 discloses a circuit 2042 having an AC signal generator 2044 inducing an alternating electric field onto transmission conductor 2046 which is connected to a first directional circuit 2048 having LEDs 1-3. LED 2 acting as a load to circuit 2048, provides the relatively high DC potential at point 2050 and a relatively lower DC potential at point 2052 to another directional circuit 2054 comprised of LEDs 4-6. This is repeated for another directional circuit 2056 and LEDs 7-9. Again, the circuit components LEDs 1-9 provide both directionality and useful work as a load in the form of producing light. According to another aspect of the invention, the circuit 2042 discloses the multiplexing possibilities of the directional circuits 2048, 2052, 2056. According to another aspect of the invention, the circuit 2042 discloses a parallel LED directional circuit.

FIG. 51 discloses a circuit 2058 to illustrate another aspect of the invention, in particular the transmission of information or data as one may use the terms. Accordingly, the alternating electric field is provided (as it could be with any embodiment disclosed herein) by either an antenna 2060 or a signal generator 2061. The alternating signal source is imposed on transmission conductor 2062. A directional circuit 2064 is comprised of a load 2066 and two diodes D1 and D2. The circuit 2058 discloses the directional DC current flow as well as an AC plus DC current flow and potential indicated by "AC+DC" in FIG. 51. This DC plus AC component is important to the transmission of information or data signals from the generators 2060, 2061.

In particular, FIG. 52 discloses a circuit 2068 having a signal generator 2070, a transmission conductor 2072, and a directional circuit 2074. The directional circuit has asymmetrical diode elements D1 and D2 and a load R1. In this and the other embodiment disclosed herein (see FIG. 51), the directional circuit 2074 is constructed to permit a DC voltage level to accrue on the transmission conductor 2072 along with the AC signal to provide an offset to the signal. This offset is preferential to the signal as the signal is ungrounded. It is believed that this may prevent noise in the system to be added to the line 2072 as a second alternating field but with reference to ground. Accordingly the noise adds to the DC level but not to the signal level in the same proportions.

Also as disclosed in FIG. 52, an output 2076 is provided which will transmit the AC signals from transmission line 2072 to an information or data signal receiver 2078 which will detect the signal riding the DC level. The DC level can easily be distinguished and handled by such a receiver as is conventional. It should be understood that the signal receiver 2078 may be of any conventional type of TTL logic device, modem, or telecommunications receiver and is believed to operate best with the preferred systems of the invention when it is not connected to earth ground or a battery ground, or a current sink or charge collector (as is the case for the working loads disclosed through out this disclosure).

According to another embodiment, FIG. 53 discloses another information or data communication circuit 2080. The circuit 2080 includes a signal generator 2082, a transmission conductor 2084, a directional circuit 2086, a data receiver 2088, and a ground switch 2090. In this embodiment, the directional circuit 2086 provides both the DC

24

power for the receiver 2088, and a data signal through output 2092 connected between the receiver input and the common connection between the conductor 2084 and directional circuit input to anode of diode D1 and cathode D2. In the meantime, the receiver is powered on the DC potential difference between D1 the relatively more positive side 2094 and D2 the relatively less positive side 2096 of the directional circuit. In this embodiment, resistor R1 is provided according to another aspect of the invention to regulate or select as desired the level of DC offset the AC data signal will have at line 2092.

According to another aspect of the invention, the ground switch 2090 is provided to provide a non-continuous connection to a circuit, such as the ground circuit disclosed in FIG. 53, to dissipate excessive accumulations of charge or voltage potentials in the circuit 2080. It is contemplated that the switch 2090 be actuated based upon a timing (such as a pre-selected clock pulse) criteria, or by a sensor (not shown) of an undesirable DC level developing in the circuit 2080. Once engaged, the circuit 2090 would dissipate the excess energy to a ground, ground, plane, capacitor, battery ground, or the like.

FIG. 54 discloses a circuit 2092 wherein directional circuits 2094-2100 are connected through a common bus conductor 2102 to provide DC power and signals from generator 2104 as described previously herein.

FIGS. 55 and 56 disclose a circuit 2104 to illustrate another aspect of the invention. Accordingly, an alternating electric field is provided to a first transmission conductor by a signal generator 2102 and a second transmission conductor is provided by an antenna 2108 (see FIG. 55) or wire 2124 (see FIG. 56) that is connected to a relatively less positive side 2114-2122 within the directional circuit 2110. A difference in DC potential between a relatively more positive side 2112 within the directional circuit, and relatively less positive side 2114-2122 is provided. Another aspect of the invention is sensing proximity with impedance changes within the directional circuits described herein (as it could be with any embodiment disclosed herein) by approaching any of the directional circuits or transmission conductors (also any of which are described herein), for example approaching 2108 (shown in FIG. 55) and/or 2124 (as shown in FIG. 56) with a conductive substance such as a person, including the touch of a person (human touch), or metallic material thereby changing the circulation of current flow within the directional circuit by changes in impedance through the capacitance of the conductive substance.

FIG. 57 discloses a circuit 2126 to illustrate another aspect of the invention. Accordingly, an alternating electric field is provided to a transmission conductor 2132 by a signal generator 2128 that provides a first voltage level output equal to that provided by the signal generator 2128. A lump inductance 2130 is provided in series of the transmission conductor 2132 between the signal generator 2128 and directional circuit 2134. The lump inductance 2130 provides an increased voltage level from the relatively lower voltage on the transmission conductor 2132 at the point 2136 between the signal generator 2128 and lump inductance 2130 and a relatively higher voltage level on the transmission conductor 2132 at the point 2138 between the lump inductance 2130 and the directional circuit 2134 thereby providing an increase in current flow within the directional circuit 2134 or electromagnetic field energy radiating from the circuit 2126. The amount of current flow within the directional circuits described herein and electromagnetic field energy external of the directional circuits described herein is dependent on the frequency of an AC

US 10,687,400 B2

25

signal provided to the transmission conductor **2132** (or any of which are described herein). In preferred embodiments, the circuits disclosed in FIGS. **44-57** may be connected to ground through capacitance. This ground connection seems to provide increased circulation current, as it is noted that the LEDs get brighter for a given alternating electromagnetic source.

FIG. **58** discloses a circuit **2140** according to the invention having a standard AC signal generator **2142** and a directional circuit **2144** that includes first and second diodes D1, D2, the first diode D1 has an anode and the second diode D2 has a cathode, which are commonly connected to the transmission conductor **2146** from the generator **2142**. The cathode of diode D1 is connected to the relatively more positive side **2148** of an organic light emitting diode (OLED) **2152** while the anode of diode D2 is connected to the relatively less positive side **150** of the OLED **2152** to form the loop circuit **2144** among the diodes D1, D2 and the OLED **2152**.

FIGS. **59**, and **61-62** disclose another embodiment of the invention having a directional organic light emitting diode ("OLED") circuit **2154** that includes a first diode D1 **2156**, a second diode D2 **2158**, and an OLED **2157**. The first diode D1 **2156** has an anode and the second diode D2 **2158** has a cathode, which are commonly connected to an input transmission conductor **2160**. The cathode of diode D1 **2156** is connected to the relatively more positive side **2162** anode of an OLED **2157** while the anode of diode D2 **2158** is connected to the relatively less positive side cathode **2164** of the OLED **2157** to form the loop circuit **2154** among the diodes D1, D2 and the OLED **2157**. The directional OLED circuit **2154** is a loop circuit which includes one or more circuit elements (e.g. diodes or OLEDs **2156**, **2157** and **2158**) causing the loop circuit to be asymmetric to current flow. Circuit element **2157** is an OLED. The directional OLED circuit **2154** does not have a continuous conductive path to earth ground, or battery ground. The directional OLED circuit **2154** develops a DC potential in response to an alternating electric field imposed on input **2160**. The directional OLED circuit **2154** is self referencing between a relatively high potential output and a relatively lower potential output. The directional OLED circuit **2154** has a resistance, inductance and capacitance that is responsive to the voltage and frequency of the alternating electric field. The directional OLED circuit **2154** has transmission conductors **2166**, **2168** connected to the directional OLED circuit **2154**.

FIG. **60** discloses another embodiment of the invention having a directional organic light emitting diode ("OLED") circuit **2170** that includes a first OLED **2172**, a second OLED **2174**, and a third OLED **2176**. The first OLED **2172** has an anode and the third OLED **2176** has a cathode, which are commonly connected to an input transmission conductor **2178** having AC signal source from a signal generator **2180**. The cathode of the first OLED **2172** is connected to the anode of the second OLED **2174** while the cathode of the second OLED **2174** is connected to the anode of the third OLED **2176** to form the loop circuit **2170** among the OLEDs 1, 2 and 3 (**2172-2176**). The directional OLED circuit **2170** can be designed with more than 3 OLEDs.

FIG. **61** discloses a circuit **2182** with the same embodiment of the invention shown in FIG. **59** (see FIG. **59**) encasing the directional OLED circuit **2154** within a package **2163**.

FIG. **62** discloses a circuit **2184** with the same embodiment of the invention shown in FIG. **59** (see FIG. **59**) with a second transmission conductor **2185** providing an input within the directional circuit **2184** at a point other than the

26

input of the first transmission conductor input of **2160**. The transmission conductors **2160** and **2185** (or any transmission conductors described herein) can act as an antenna and cause the directional OLED circuit **2184** to react to the proximity of conductive substances near the transmission conductors **2160** and **2185**. In preferred embodiments, the circuits disclosed in FIGS. **59-66** may be connected to ground through capacitance at a point within the directional circuit such as transmission conductor **2185** (e.g. FIG. **62**). This ground connection seems to provide increased circulation current, as it is noted that the OLEDs get brighter for a given alternating electromagnetic source.

FIG. **63** discloses a matrix circuit **2186** comprised of twelve circuits **2154** (e.g. FIG. **61**). The circuits in the matrix **2186** are connected commonly to a transmission conductor **2188**.

FIG. **64** discloses a matrix circuit **2190** identical to matrix circuit **2186** but that the circuits **2191** employ only LEDs or optionally OLEDs.

FIG. **65** discloses a matrix circuit **2192** identical to matrix circuit **2186** but that the circuits **2193** in the matrix **2192** are connected commonly to one end of a lump inductance **2196** placed in series of the transmission conductor **2194** between the signal generator **2198** and the matrix circuit.

FIG. **66** discloses a matrix circuit **2200** identical to matrix circuit **2192** but that the circuits in the matrix **2200** are connected to individual lump inductances **2201-2206** which can be of equal or different values.

FIG. **67** shows a device **2482** comprising individual light emitting diode circuits **2484** on a flexible printed circuit board having a mirror like reflective material or coating **2488** designed into or on the flexible printed circuit board in an area at least near the light emitting diodes for providing more efficient light output from the circuit board areas surrounding the light emitting diodes by having the flexible printed circuit board reflect light rather than absorb it. Power connection points **2490** and **2492** are provided to the board.

FIG. **68** shows a device **2494** comprising a device **2496** identical to the device shown in FIG. **67** adhered to a device **2498** having a cylindrical shape for providing improved uniformity and increased angle of light output from device **2496**.

A circuit includes a first source for providing an alternating electric field, a directional circuit is connected to the first source for providing an alternating electric field by a transmission conductor there being no conductive DC path is provided back from the directional circuit to the first source for providing an alternating electric field. The directional circuit being a loop circuit which includes one or more circuit elements causing the loop circuit to be asymmetric to current flow; the directional circuit having no continuous conductive path to earth ground, or battery ground, the directional circuit thereby developing a DC potential in response to the alternating electric field which is self referencing between a relatively high potential output and a relatively lower potential output. One or more loads connected to the directional circuit, the one or more loads also not having a continuous conductive path to earth ground or a battery ground. The load is not provided with a continuous connection to earth ground, or battery ground. The load may be provided with a capacitive connection to earth ground, or battery ground. The DC current flow within the directional circuit is adjustable by tuning the directional circuit to different frequencies of an alternating electric field thereby causing the directional circuit to reach a resonant state. The current flow increases within the directional circuit and the electromagnetic field is concentrated within the directional

US 10,687,400 B2

27

circuit when the directional circuit is tuned to a resonant frequency. The directional circuit being tuned out of its resonant frequency and providing a larger electromagnetic field surrounding the exterior of the directional circuit enables the directional circuit to be responsive to the proximity of objects having a capacitance that enter the electromagnetic field. The directional circuit is tuned towards resonance as conductive objects enter the electromagnetic field of the directional circuit.

The above-described embodiments of the present invention are intended to be examples only. Alterations, modifications and variations may be effected to the particular embodiments by those of ordinary skill in the art without departing from the scope of the invention, which is defined by the claims appended hereto.

What is claimed is:

1. A lighting system comprising:
a data communication circuit comprising an LED circuit and an antenna;
wherein the LED circuit comprises a plurality of LEDs connected in series, parallel, or opposing parallel;
wherein the LED circuit and the antenna are integrated in a package;
wherein the data communication circuit is integrated into a lighting device;
wherein the lighting device is adapted to be connected to a socket;
wherein the lighting device is configured to transmit data signals to or receive data signals from at least one telecommunications device; and
wherein the telecommunications device comprises a circuit configured to detect human touch via capacitive sensing.
2. The lighting system of claim 1, wherein the package comprises a reflective material.
3. The lighting system of claim 1, further comprising the telecommunications device.
4. The lighting system of claim 1, wherein the telecommunications device is portable.
5. The lighting system of claim 4, wherein the portable telecommunications device further comprises at least one OLED, and wherein the portable telecommunications device is configured to receive power wirelessly.
6. The lighting system of claim 1, further comprising a current limiting device coupled to the LED circuit.
7. A lighting system comprising:
an LED circuit array comprising an LED circuit comprising a plurality of LEDs connected in series;
a capacitor;
a bridge rectifier configured to receive an input AC voltage from a mains power source;
a driver connected to the bridge rectifier and configured to provide a rectified output AC voltage to the LED circuit array;
wherein a forward voltage of the LEDs of the LED circuit array matches the rectified input AC voltage output of the driver; and
wherein the LED circuit array, the capacitor, the bridge rectifier, and the driver are all mounted on a single substrate.
8. The lighting system of claim 7, further comprising power factor correction circuitry.
9. The lighting system of claim 7, wherein the LEDs are coated or doped with at least one of a phosphor, nano-crystals, or a light changing or enhancing substance.

28

10. The lighting system of claim 7, wherein the rectified output AC voltage provided to the LED circuit array is relatively close to the input AC voltage input received from the mains power source.

11. The lighting system of claim 7, wherein the capacitor is configured to smooth the rectified output AC voltage.

12. The lighting system of claim 7, further comprising a data communication circuit comprising an antenna, wherein the data communication circuit is integrated with the substrate.

13. The lighting system of claim 12, wherein the capacitor is a first capacitor, wherein the data communication circuit further comprises an inductor and a second capacitor.

14. An LED lighting device comprising:
a plurality of LED circuits connected in parallel, wherein each LED circuit comprises at least two LEDs;
wherein the LED circuits are mounted on a reflective substrate;
an LED driver configured to receive one of at least two different input voltage levels from an AC mains power source; and
wherein the LED circuits and the LED driver are integrated in a single package.

15. The LED lighting device of claim 14, further comprising a 3-way switch.

16. The LED lighting device of claim 14, further comprising a data communication circuit comprising an antenna, an inductor and a capacitor, wherein the data communication circuit is integrated in the single package.

17. The LED lighting device of claim 14, wherein the LEDs are coated or doped with at least one of a phosphor, nano-crystals, or a lighting changing or enhancing substance.

18. The lighting device of claim 14, wherein the driver comprises power factor correction circuitry.

19. The lighting device of claim 14, wherein the driver comprises soft start circuitry.

20. The lighting device of claim 14, wherein the driver comprises at least one field effect transistor.

21. A lighting device comprising:
a data communication circuit having at least one LED circuit, wherein the at least one LED circuit has at least two LEDs connected in series, parallel or opposing parallel, and wherein the at least two LEDs are a same color or different colors;

wherein the data communication circuit having the at least one LED circuit is integrated into the lighting device; wherein the lighting device can transmit data signals to or receive the data signals from at least one portable telecommunications device; and

wherein the portable telecommunications device comprises a circuit that can detect a human touch via capacitive sensing, and wherein the portable telecommunications device further comprises at least one LED that provides light based upon detection of the human touch.

22. The lighting device of claim 21, further comprising the portable telecommunications device.

23. The lighting device of claim 21, wherein the portable telecommunications device further includes at least one OLED.

24. The lighting device of claim 21, wherein the portable telecommunications device is configured to receive power wirelessly.

25. The lighting device of claim 21, wherein the at least one LED circuit is mounted on a reflective printed circuit board.

US 10,687,400 B2

29

30

26. The lighting device of claim **21**, wherein the lighting device further comprises:
integrated circuitry that allows adjustment of a brightness of the at least one LED circuit.

* * * * *

5