

No. 2021-2348

United States Court of Appeals
for the Federal Circuit

LKQ CORPORATION, KEYSTONE AUTOMOTIVE INDUSTRIES, INC.,

Appellants,

v.

GM GLOBAL TECHNOLOGY OPERATIONS LLC,

Appellee.

Appeal from the United States Patent and Trademark Office,
Patent Trial and Appeal Board in No. IPR2020-00534

(JJ. Scott A. Daniels, Grace K. Obermann, and Christopher G. Paulraj)

EN BANC REPLY BRIEF OF APPELLANTS
LKQ CORPORATION AND KEYSTONE AUTOMOTIVE INDUSTRIES, INC.

BARRY F. IRWIN
IFTEKHAR A. ZAIM
ANDREW C. HIMEBAUGH
ARIEL H. KATZ
IRWIN IP LLP
150 N. Wacker Dr., Suite 700
Chicago, IL 60606
(312) 667-6080
birwin@irwinip.com
izaim@irwinip.com
ahimebaugh@irwinip.com
akatz@irwinip.com

MARK A. LEMLEY
MARK P. MCKENNA
LEX LUMINA PLLC
745 Fifth Ave., Suite 500
New York, NY 10151
(646) 898-2055
mlemley@lex-lumina.com
mark@lex-lumina.com

Counsel for Appellants
LKQ Corporation and Keystone Automotive Industries, Inc.

UNITED STATES COURT OF APPEALS
FOR THE FEDERAL CIRCUIT

CERTIFICATE OF INTEREST

Case Number 2021-2348

Short Case Caption LKQ Corporation, et al. v. GM Global Technology Operations LLC

Filing Party/Entity LKQ Corporation

Instructions: Complete each section of the form. In answering items 2 and 3, be specific as to which represented entities the answers apply; lack of specificity may result in non-compliance. **Please enter only one item per box; attach additional pages as needed and check the relevant box.** Counsel must immediately file an amended Certificate of Interest if information changes. Fed. Cir. R. 47.4(b).

I certify the following information and any attached sheets are accurate and complete to the best of my knowledge.

Date: 03/23/2023

Signature: /s/ Barry F. Irwin

Name: Barry F. Irwin

<p>1. Represented Entities. Fed. Cir. R. 47.4(a)(1).</p>	<p>2. Real Party in Interest. Fed. Cir. R. 47.4(a)(2).</p>	<p>3. Parent Corporations and Stockholders. Fed. Cir. R. 47.4(a)(3).</p>
<p>Provide the full names of all entities represented by undersigned counsel in this case.</p>	<p>Provide the full names of all real parties in interest for the entities. Do not list the real parties if they are the same as the entities.</p> <p><input checked="" type="checkbox"/> None/Not Applicable</p>	<p>Provide the full names of all parent corporations for the entities and all publicly held companies that own 10% or more stock in the entities.</p> <p><input type="checkbox"/> None/Not Applicable</p>
<p>LKQ Corporation</p>		<p>None</p>
<p>Keystone Automotive Industries, Inc,</p>		<p>LKQ Corporation</p>

Additional pages attached

4. Legal Representatives. List all law firms, partners, and associates that (a) appeared for the entities in the originating court or agency or (b) are expected to appear in this court for the entities. Do not include those who have already entered an appearance in this court. Fed. Cir. R. 47.4(a)(4).

None/Not Applicable Additional pages attached

Reid Huefner	Margaret Herrmann	

5. Related Cases. Provide the case titles and numbers of any case known to be pending in this court or any other court or agency that will directly affect or be directly affected by this court's decision in the pending appeal. Do not include the originating case number(s) for this case. Fed. Cir. R. 47.4(a)(5). See also Fed. Cir. R. 47.5(b).

None/Not Applicable Additional pages attached

LKQ Corp., et al. v. GM Global Technology Operations LLC, Fed. Cir. Case No. 2022-1253		

6. Organizational Victims and Bankruptcy Cases. Provide any information required under Fed. R. App. P. 26.1(b) (organizational victims in criminal cases) and 26.1(c) (bankruptcy case debtors and trustees). Fed. Cir. R. 47.4(a)(6).

None/Not Applicable Additional pages attached

TABLE OF CONTENTS

INTRODUCTION 1

ARGUMENT..... 2

I. *KSR* Abrogated *Rosen* and *Durling*..... 2

 A. Design Patents are Held to the Same Obviousness Standard as Utility Patents 2

 1. *Design and Utility Patents are Subject to the Same Constitutional and Statutory Prohibition Against Claiming Obvious Subject Matter* 2

 2. *GM’s Arguments for Applying a Special Test to Design Patents are Specious* 3

 B. The *Rosen-Durling* Test is Inconsistent with *KSR*..... 6

 1. *GM Misstates the Scope and Holding of KSR*..... 6

 2. *Rosen’s Primary Reference Requirement is Inconsistent with KSR, and GM Misstates it to Argue Otherwise* 8

 a. *The Rosen Reference Analysis Excludes The DOSA*..... 8

 b. *The Rosen Reference Requirement is Not Flexible* 9

 c. *The Rosen Reference Requirement is Irreconcilable with the Supreme Court’s Decision and Mode of Analysis in Whitman Saddle* 13

 3. *Durling’s “So-Related” Requirement is Also Inconsistent with KSR* 15

 4. *This Court Has Not Condoned Rigid Frameworks Post KSR*..... 16

 a. *This Court Does Not Apply a Rigid Analogous Art “Test”* 16

b.	This Court Does Not Apply a Rigid Lead Compound “Test”	18
II.	The Appropriate Test for Evaluating Design Patent Obviousness is <i>Graham</i> as Elaborated in <i>KSR</i>	20
A.	<i>Graham</i> Provides Sufficient Guidance.....	21
B.	Patent Examiners Would Not be Left Adrift	21
III.	GM’s Claim that the <i>Rosen-Durling</i> Test has Long Worked is Myopic and Wrong	23
IV.	Stare Decisis Cuts Against Retaining <i>Rosen-Durling</i> Because It Is Inconsistent with Controlling Precedent.....	28
V.	Congress has Not Endorsed <i>Rosen-Durling</i>	29
VI.	GM and Amici’s Policy Arguments Do Not Support Granting Patents on Obvious Designs	29
	CONCLUSION	32

TABLE OF AUTHORITIES

Cases

<i>Altana Pharma AG v. Teva Pharms. USA, Inc.</i> , 566 F.3d 999 (Fed. Cir. 2009)	19
<i>Application of Antle</i> , 444 F.2d 1168 (C.C.P.A. 1971)	17
<i>Application of Winslow</i> , 365 F.2d 1017 (C.C.P.A. 1966)	16
<i>Campbell Soup Co. v. Gammon Plus, Inc.</i> , 10 F.4th 1268 (Fed. Cir. 2021)	10, 12
<i>Campbell Soup Co. v. Gamon Plus, Inc.</i> , 939 F.3d 1335 (Fed. Cir. 2019)	10
<i>Cnty. for Creative Non-Violence v. Reid</i> , 490 U.S. 730 (1989)	30
<i>Daiichi Sankyo Co. v. Matrix Lab'ys, Ltd.</i> , 619 F.3d 1346 (Fed. Cir. 2010)	20
<i>DePuy Spine, Inc. v. Medtronic Sofamor Danek, Inc.</i> , 567 F.3d 1314 (Fed. Cir. 2009)	17
<i>Durling v. Spectrum Furniture Co.</i> , 101 F.3d 100 (Fed. Cir. 1996)	8, 9
<i>Egyptian Goddess, Inc. v. Swisa, Inc.</i> , 543 F.3d 665 (Fed. Cir. 2008) (en banc)	5
<i>Gorham Mfg. Co. v. White</i> , 81 U.S. 511 (1871)	5
<i>Graham v. John Deere Co. of Kansas City</i> , 383 U.S. 1 (1966)	2, 20, 32
<i>Halo Elecs., Inc. v. Pulse Elecs., Inc.</i> , 579 U.S. 93 (2016)	30

In re Bigio,
 381 F.3d 1320 (Fed. Cir. 2004)17

In re Dillon,
 919 F.2d 688 (Fed. Cir. 1990) (en banc)18

In re Gleizer,
 356 F. App’x 415 (Fed. Cir. 2009)17

In re Jolley,
 308 F.3d 1317 (Fed. Cir. 2002)24

In re Laverne,
 356 F.2d 1003 (C.C.P.A. 1966)..... 5

In re Maatita,
 900 F.3d 1369 (Fed. Cir. 2018)23

In re Mouttet,
 686 F.3d 1322 (Fed. Cir. 2012)14

In re Nalbandian,
 661 F.2d 1214 (C.C.P.A. 1981).....3, 5

In re Oetiker,
 977 F.2d 1443 (Fed. Cir. 1992)22

Jore Corp. v. Kouvato, Inc.,
 117 F. App’x 761 (Fed. Cir. 2005)10, 15

KSR Int’l Co. v. Teleflex Inc.,
 550 U.S. 398 (2007).....*passim*

LKQ Corp, et al v. GM Global Technology Operations LLC,
 No. PGR2020-000005 (P.T.A.B. May 5, 2020).....28

Macsports, Inc. v. Idea Nuevo, Inc.,
 No. IPR2018-01006 (P.T.A.B. Nov. 13, 2018).....27

MRC Innovations, Inc. v. Hunter Mfg., LLP,
 747 F.3d 1326 (Fed. Cir. 2014)10

Netflix, Inc. v. DivX, LLC,
80 F.4th 1352 (Fed. Cir. 2023)18

Otsuka Pharm. Co. v. Sandoz, Inc.,
678 F.3d 1280 (Fed. Cir. 2012)20

Sears, Roebuck & Co. v. Stiffel Co.,
376 U.S. 225 (1964).....32

Smith v. Whitman Saddle Co.,
148 U.S. 674 (1893).....*passim*

Takeda Chem. Indus., Ltd. v. Alphapharm Pty., Ltd.,
492 F.3d 1350 (Fed. Cir. 2007)19

Titan Tire Corp. v. Case New Holland, Inc.,
566 F.3d 1372 (Fed. Cir. 2009)6, 10, 29

Troy v. Samson Mfg. Corp.,
758 F.3d 1322 (Fed. Cir. 2014)15

USA v. Sandoz, Inc.,
574 U.S. 318 (2015).....29

Vitro Packaging, LLC v. Saverglass, Inc.,
No. IPR2015-00947, 2015 WL 5766302 (P.T.A.B. Sept. 29, 2015)27

Yamanouchi Pharm. Co. v. Danbury Pharmacal, Inc.,
231 F.3d 1339 (Fed. Cir. 2000)19

Statutes

35 U.S.C. § 289 5

35 U.S.C. §§ 103, 171.....3, 6

U.S. Const., art. I 2

Regulations

37 C.F.R. §§ 1, 11, 41 (2024).....22

Other Authorities

Craig Deutsch, Jennifer Huang & Grace Kim, <i>How to Succeed in Design Patent Cases at the PTAB</i> (May 3, 2022) (https://www.fr.com/uploads/610-2022-05-03-article-law360-designpatentcasesatthetab-deutsch-huang-kim.pdf)	25
Design Education Today: Technical Contexts, Programs and Best Practices (2019)	31
FishRichardson, Webinar <i>Design Patents at the PTAB</i> , YouTube (June 14, 2023) (https://www.youtube.com/watch?v=ujNVECHoQy8)	26
James M. Flammang & Ron Kowalke, <i>Standard Catalog of American Cars, 1976-1999</i> (3rd ed. 1999).....	31
Manual of Patent Examining Procedure § 2142	22
Manual of Patent Examining Procedure § 2145	22
Ryan T. Holte & Ted Sichelman, <i>Cycles of Obviousness</i> , 105 Iowa L.J. 107 (2019)	6
Sarah Burstein & Saurabh Vishnubhakat, <i>The Truth About Design Patents</i> , 71 Am. U.L. Rev. 1221 (2022).....	23
United States Patent and Trademark Office, <i>Become a Design Patent Examiner</i> (2023) (https://www.uspto.gov/jobs/become-design-patent-examiner)	22

INTRODUCTION

Design patents are constitutionally and statutorily prohibited from covering obvious designs. But the *Rosen-Durling* framework allows just that. This Court should find that the *Rosen-Durling* framework was overruled by or is incompatible with *KSR* and direct that design patent obviousness be evaluated based on the inquiry *KSR* demands: whether a designer of ordinary skill in the art would have found the claimed design obvious. That is not a rudderless approach. The rudder is *Graham* and the evidence that establishes what a designer would have found obvious. *See Smith v. Whitman Saddle Co.*, 148 U.S. 674, 681 (1893) (finding design obvious in light of evidence “that there were several hundred styles of saddles or saddletrees ... and that it was customary for saddlers to vary the shape and appearance of saddletrees in numerous ways, according to the taste and fancy of the purchaser”). What is rudderless is an approach that invites the factfinder to rely on its own “almost instinctive” assessment of “basic similarity” as a prerequisite to even considering what a designer would have found obvious.

GM and its amici make two contradictory arguments to justify a separate design patent obviousness regime. First, they argue that design is so uniquely susceptible to hindsight bias that the rigid framework of *Rosen-Durling* is necessary. Second, GM reinvents each part of *Rosen-Durling* and argues that the framework is consistent with *KSR* because it is *not* rigid, but rather “expansive and flexible.”

Both arguments are wrong. First, *KSR*'s prescribed analysis already prevents hindsight bias by requiring an articulated rationale for why a design would have been obvious. Second, as the Government agrees, the rules articulated by *Rosen-Durling* are rigidly sequential and therefore incompatible with *KSR*. Even when this Court has found designs to be obvious, its determinations have been predicated on the court's identification of a *Rosen* reference based on its own instinctive assessment of the designs' visual similarities or differences, and not an evaluation of whether the claimed design would have been obvious to a designer. Whether those decisions sometimes reached the right results, they did not do so through an analysis consistent with *KSR* or that could predictably be applied by lower tribunals.

ARGUMENT

I. *KSR* ABROGATED *ROSEN* AND *DURLING*

A. Design Patents are Held to the Same Obviousness Standard as Utility Patents

1. Design and Utility Patents are Subject to the Same Constitutional and Statutory Prohibition Against Claiming Obvious Subject Matter

Design and utility patents are subject to the same constitutional mandate to promote the progress of useful arts. That constitutional standard prohibits patents covering obvious subject matter. U.S. Const., art. I, § 8; *Graham v. John Deere Co. of Kansas City*, 383 U.S. 1, 5-12 (1966). Design patents are also subject to the same statutory prohibition against patents claiming that which was obvious to a person

having ordinary skill in the art (“POSITA”). 35 U.S.C. §§ 103, 171; *In re Nalbandian*, 661 F.2d 1214, 1216 (C.C.P.A. 1981). GM does not contest this. *See generally* Dkt. 166 (“GM Response”).

2. *GM’s Arguments for Applying a Special Test to Design Patents are Specious*

GM first argues that design patents require a special regime because designs are not directed toward solving any particular problem. GM Response at 13-15. This is contrary to GM’s own evidence in this case. As GM’s expert said, designers do solve problems. *See e.g.* Appx0880 (Peters Decl., ¶ 10) (“Good automotive design is a three-dimensional product solution to a problem or challenge Ultimately, the designer’s focus is driven by the customer.”). Design solutions are informed by numerous inputs and limitations, including market pressure, trends and fashions, engineering constraints, and brand identity. Appx1302 (Hill Decl., ¶ 12 *et seq.*); *see also* Appx1335-1336 (Hill Decl., ¶¶ 57-58) (detailing a specific problem faced by a designer); Dkt. 181, at 5-7. *See also Whitman Saddle*, 148 U.S. at 680-81. Further, even if designers were not seeking to solve particular problems, that would not justify a different design patent regime.

Second, GM argues that design patents require a special obviousness regime because designs are allegedly more susceptible to hindsight bias. GM Response at

14-17. There is no evidence supporting GM’s premise, but regardless, as the Government’s brief in *KSR* explained, the fear of hindsight bias is overstated:

The Federal Circuit’s rigid [TSM] test underestimates the capacity of courts and the PTO to avoid the influence of hindsight... ***[In numerous other legal contexts], as in Graham, the Court has consistently recognized that decisionmakers can avoid the improper influence of hindsight*** by maintaining conscious awareness of its potentially distorting influence in the decision-making process. ... ***There is no reason to think that courts in patent cases cannot be similarly discerning.***

Brief for the United States as Amicus Curiae Supporting Petitioner at 21, *KSR*, No. 04-1350 (emphases added). Like the TSM test, the *Rosen-Durling* test “underestimates the capacity of courts and patent examiners to avoid improper reliance on hindsight. The test exacts a heavy cost in the form of unwarranted extension of patent protection to obvious subject matter.” *See id.* at 10. And, as the Supreme Court found in *KSR*, risk of hindsight bias is adequately addressed by warning factfinders against the temptation to rely on *ex post* reasoning and does not justify implementation of rigid rules. *KSR Int’l Co. v. Teleflex Inc.*, 550 U.S. 398, 421 (2007).

Third, GM and some of its amici argue that *Rosen*’s requirement of a single reference that is “basically the same” is inexplicably “necessary to evaluate designs as a whole.” *See e.g.*, GM Response at 18. But the Supreme Court’s comprehensive evaluation of the entire claimed design in *Whitman Saddle* demonstrates that no

special test is needed to evaluate a design as a whole. *See Whitman Saddle*, 148 U.S. at 681. *See also* Opening Brief at 57-58 (citing decisions of other Circuits analyzing design patent obviousness under *Graham*). If anything, the *Rosen* reference requirement misdirects the analysis away from the design as a whole and toward minute differences between the claimed design and a single prior art reference in isolation.

Lastly, GM argues that design patent obviousness requires a special regime because design patent law differs from utility patent law in other ways. GM Response at 15-16. It is true that design law differs in some respects from utility patents. For example, design patent damages are specifically differentiated by statute. 35 U.S.C. § 289. As to infringement and claim construction, those are judicially created doctrines, not statutory mandates, and in contrast with obviousness, the Supreme Court's precedent required this Court to differentiate those doctrines. *Egyptian Goddess, Inc. v. Swisa, Inc.*, 543 F.3d 665, 670, 678 (Fed. Cir. 2008) (en banc) (citing *Gorham Mfg. Co. v. White*, 81 U.S. 511, 527-29, (1871)).

The same is not true of obviousness, however. Designs are not subject to a different statutory obviousness rule; rather, the same constitutional and statutory obviousness rule applies to designs. 35 U.S.C. §§ 103, 271.¹ Indeed, the

¹ GM cites *Nalbandian* for the proposition that “[i]n the field of design, the [obviousness] analysis is not so easy.” *See* GM Response at 15 (quoting

Government concluded that “there is no reason that *KSR*’s discussion of the expansive and flexible principles undergirding the obviousness inquiry should not be equally applicable in the design patent context.” United States Amicus Brief at 18; accord *Titan Tire Corp. v. Case New Holland, Inc.*, 566 F.3d 1372, 1384 (Fed. Cir. 2009).

B. The *Rosen-Durling* Test is Inconsistent with *KSR*

1. *GM Misstates the Scope and Holding of KSR*

GM misstates *KSR*’s holding when arguing *KSR* did not abrogate the TSM test and simply overruled its application. GM Response at 30. *KSR* unquestionably abrogated this Court’s rule that a patent could only be invalidated for obviousness if the TSM test was met. *KSR*, 550 U.S. at 398, 419 (“There is no necessary inconsistency between the idea underlying the TSM test and the *Graham* analysis. But when a court transforms the general principle into a rigid rule that limits the obviousness inquiry, as the Court of Appeals did here, it errs.”); see also Ryan T. Holte & Ted Sichelman, *Cycles of Obviousness*, 105 Iowa L.J. 107, 159 (2019) (“These findings largely indicate that both district courts and the Federal Circuit

Nalbandian, 661 F.2d at 1216 (quoting *In re Laverne*, 356 F.2d 1003, 1006 (C.C.P.A. 1966))). However, *Nalbandian* quoted that language in *Laverne* for the express purpose of rejecting it, and the court *dismissed* concerns that *Graham* could not be applied to design patents. *Nalbandian*, 661 F.2d at 1216-17 (applying the *Graham* test to design-patent cases “has been found helpful to courts ... because of the objective evidence which can be brought to bear on the question of obviousness.”).

have rejected a rigid formulation of the TSM test following *KSR*.”). That does not mean the presence or absence of a suggestion or motivation to make a modification is irrelevant. To the contrary, *KSR* itself asks what a person of skill in the art would be motivated to do. *KSR*, 550 U.S. at 418, 420. But the Court made clear: an express teaching is not the only reason someone might combine prior art references. *Id.* at 418-19. Similarly, finding a single reference that is “basically the same” as the invention cannot be the only way to prove the obviousness of a design.

GM also wrongly argues that *KSR* only prohibited rigid rules that deny factfinders recourse to common sense but allowed other frameworks, including guardrails against hindsight. GM Response at 29 *et seq.* First, *Rosen-Durling* does deny factfinders access to common sense in evaluating what would have been obvious to an ordinary designer. Even if common sense suggests that a design is obvious, the design must be deemed non-obvious unless *Rosen-Durling*’s rigid steps are satisfied, and the framework mandates that conclusion ***without even allowing the factfinder to look at*** other prior art references or consider any reason a designer might have had to modify or combine references. Second, *KSR* was not as limited as GM argues; it rejected rigid and mandatory formulas that constrain the obviousness analysis. *KSR*, 550 U.S. at 419.

2. Rosen’s Primary Reference Requirement is Inconsistent with KSR, and GM Misstates it to Argue Otherwise

a. The Rosen Reference Analysis Excludes The DOSA

Under *Rosen-Durling*, the obviousness analysis cannot proceed unless there is a single prior art reference that is “basically the same” as the claimed design. *Rosen* represents a prejudgment that, as a matter of law, no design patent can ever be obvious unless there was already something that was “basically the same.” Opening Brief at 15-16. It is difficult to imagine a more rigid rule than “if you don’t have the *Rosen* reference, we don’t look at the prior art.” Dkt. 42, Hearing Recording at 15:40-15:50 (Clevenger, J., describing the *Rosen* rule).

Rosen’s rigid and restrictive primary reference requirement cannot satisfy *KSR*’s demand for an expansive and flexible inquiry, particularly since it excludes the DOSA from the entire analysis until the judge or factfinder makes the “almost instinctive” determination that the prior art is “basically the same.” *Durling v. Spectrum Furniture Co.*, 101 F.3d 100, 103 (Fed. Cir. 1996).

GM seeks to dodge this fundamental shortcoming by mischaracterizing the primary reference requirement as focusing on “whether a factfinder can determine ‘almost instinctively’ *that a skilled artisan would believe* ‘two designs create basically the same visual impression.’” GM Response at 32 (emphasis added). But the primary reference requirement **does not** consider a skilled artisan’s belief about whether two designs create basically the same visual impression—it specifically

gives that determination to the factfinder based on its own “almost instinctive” judgment. *Durling*, 101 F.3d at 103. And GM’s rewritten test would still be a rigid rule contrary to the constitutional and statutory mandate because it first requires an ordinary artisan to think that the claimed design creates basically the same visual impression as a single prior art design before the actual question can be considered—whether the design would have been obvious to an ordinary artisan.

b. The *Rosen* Reference Requirement is Not Flexible

GM further backpedals on the rigid framework of *Rosen-Durling* by arguing that even though the test may be written in a rigid manner, it is not being applied rigidly. GM Response at 33-35. First, as the US Amicus Brief demonstrated, *Rosen* imposes rigid rules that have been applied *more* rigidly over time, not less rigidly. Dkt. 120, at 11-12, 22-25 (*Rosen-Durling* imposes “categorical rules” that “conflict with the more expansive and flexible approach to obviousness espoused in *Graham* and *KSR*, as well as other Supreme Court cases rejecting bright-line rules that were not adequately grounded in the Patent Act,” and the law should not “cut off the obviousness inquiry” for lack of a reference “having a similar overall visual effect as the claimed design.”). Second, GM’s argument echoes that advanced by defenders of the TSM test in the run-up to *KSR*.² The Supreme Court rejected this

² See Brief for Appellee at 18, *KSR*, No. 04-1350 (“In contrast to the characterization of some commentators, the suggestion is not a rigid categorical rule. On the whole,

argument because flexible applications of the test were not on appeal; *KSR*, like this case, involved an inflexible application of the test. *See* 550 U.S. at 422 (addressing decisions that purportedly applied TSM more broadly, and stating “[t]hose decisions, of course, are not now before us and do not correct the errors of law made by the Court of Appeals in this case.”).

The cases GM cites for the proposition that *Rosen* is applied flexibly reflect only a minimal level of difference or creativity between the primary reference and the patent, as several of the cases themselves acknowledge. *See, e.g., Campbell Soup Co. v. Gamon Plus, Inc.*, 939 F.3d 1335, 1340-41 (Fed. Cir. 2019) (there were only “ever-so-slight differences in design”); *Campbell Soup Co. v. Gammon Plus, Inc.*, 10 F.4th 1268, 1275 (Fed. Cir. 2021) (“side-by-side comparison ... shows the two are virtually indistinguishable.”); *Jore Corp. v. Kouvato, Inc.*, 117 F. App’x 761, 763 (Fed. Cir. 2005) (“the two bits are almost identical”); *MRC Innovations, Inc. v. Hunter Mfg., LLP*, 747 F.3d 1326, 1333 (Fed. Cir. 2014) (“That there are slight differences ... does not defeat a claim of obviousness; if the designs were identical, no obviousness analysis would be required.”); *Titan Tire*, 566 F.3d at 1381. This is further evident from a visual comparison:

the jurisprudence of obviousness, as developed by the Federal Circuit, appears relatively stable and increasingly flexible.”) (internal citations and quotations omitted).

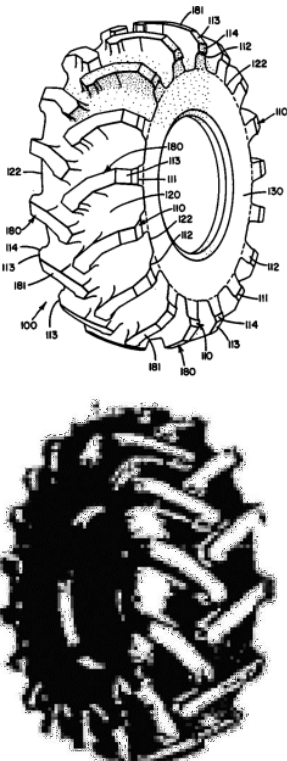
<i>Titan Tire (2009)</i>	
PATENTED DESIGN	PRIOR ART
	

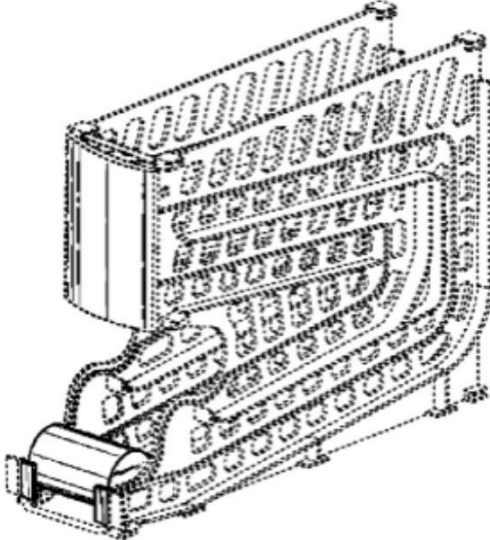
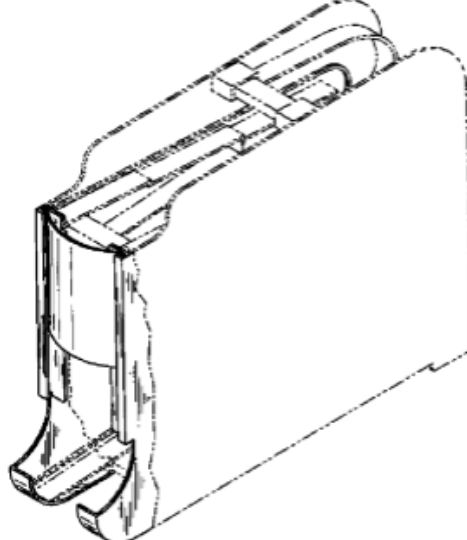
<i>Campbell Soup I & II (2019, 2021)</i>	
PATENTED DESIGN	PRIOR ART
	

The primary references in those cases are so similar that they cannot prove any meaningful flexibility in the rule.

Even GM acknowledges that *Rosen* prohibits prior art references from serving as primary references when they have “substantial differences” from the claimed design or the prior art designs “would require major modifications.” GM Response at 33 (citing *Campbell II*, 10 F.4th at 1275). But major modifications of a design can nonetheless be obvious. Indeed, the Supreme Court in *Whitman Saddle* found it obvious to conjoin the front half of one saddle design with the rear half of another. *Whitman Saddle*, 148 U.S. at 680. A half-saddle’s difference is a substantial difference—or else “substantial difference” has no meaning. *Accord* US Amicus Brief, at 24 (“neither prior-art saddle would likely qualify as ‘basically the same’ as the claimed design or ‘so related’ to each other”).

As the Government acknowledges, this case is an example of *Rosen-Durling* being applied inflexibly. *See id.* at 25 (“the facts of this case highlight the need for a more expansive and flexible approach ...” because “the ’625 patent design is visually quite similar to the prior art design depicted in Lian,” and yet the *Rosen-Durling* test prevented the Board from considering whether “missing features could be found in other similar prior-art references or could be shown to be commonly used elements of automotive styling[.]”).

c. The *Rosen* Reference Requirement is Irreconcilable with the Supreme Court’s Decision and Mode of Analysis in *Whitman Saddle*

GM’s attempt to reconcile *Rosen-Durling* with *Whitman Saddle* highlights the indefensibility of *Rosen-Durling*. See GM Response at 37-41. GM posits that the Supreme Court in *Whitman Saddle* treated the Granger saddle as a primary reference akin to what is required under *Rosen-Durling*. *Id.* But the Supreme Court did no such thing; its analysis was nothing like *Rosen-Durling* and instead resembled the approach in *Hotchkiss* and later mandated by *KSR*. The *Whitman Saddle* Court began its obviousness analysis with the ordinary designer and a range of prior art, finding “that there were several hundred styles of saddles or saddletrees belonging to the prior art, and that it was customary for saddlers to vary the shape and appearance of saddletrees in numerous ways....” *Whitman Saddle*, 148 U.S. at 681. The Court did not select any reference as “primary;” to the contrary, it discussed the claimed design as combining halves of two different prior art saddles. See *id.* at 680-81 (“the front half of the Granger and the rear half of the Jenifer, ..., make up the saddle in question. ... Nothing more was done in this instance (except as hereafter noted) than to put the two halves of these saddles together in the exercise of the ordinary skill of workmen of the trade, and in the way and manner ordinarily done.”). Not only did the entire rear half of the design differ from Granger, but the front half did too in the drop-off along the rear of its pommel. *Id.* at 681-82.

Whitman Saddle never assessed “basic similarity” because the requirement for a reference that was “basically the same” did not exist until *Rosen* invented it nearly a century later. See Dkt. 42, Hearing Recording, at 3:21-4:00 (J. Clevenger noting that *Rosen* misstated *Jennings* in imposing this requirement). *Whitman Saddle* simply never contemplated a primary reference requirement such as *Rosen*’s, much less *Rosen-Durling*’s rigid and sequential framework. As the Government noted, “*Rosen*’s ‘basically the same’ and *Durling*’s ‘so-related’ inquiries ... conflict with the obviousness approach in early Supreme Court precedent.” US Amicus Brief at 23 (citing *Whitman Saddle*, 148 U.S. 674).

That *Whitman Saddle* described the patented design’s combination in terms of its modification of the Granger saddle rather than the Jenifer saddle does not mean Granger was a “primary reference” in the *Rosen* sense. When describing a modification, one must choose a starting point, and *Whitman Saddle*’s selection of Granger rather than Jenifer was just a matter of presentation. See *In re Mouttet*, 686 F.3d 1322, 1333 (Fed. Cir. 2012) (“characterization ... of prior art as ‘primary’ or ‘secondary’ is merely a matter of presentation with no legal significance.”).

GM’s bid to save *Rosen-Durling* by analogizing *Jore*’s application of that framework to *Whitman Saddle* is also unavailing. The difference between the two decisions is in their **approach** to obviousness. *Whitman Saddle* analyzed the claimed design and the prior art in detail to determine **whether a designer would have found**

the claimed design obvious. *Jore* merely compared the visual appearances of the primary reference and the claimed design for basic similarity per *Rosen*; the court refused to consider any expert viewpoint or supporting prior art until that primary reference was identified based on visual similarity alone. Compare *Whitman Saddle*, 148 U.S. at 679-82 with *Jore*, 117 F. App'x at 762-65 (Fed. Cir. 2005) (“the two bits are almost identical”).

The *Rosen-Durling* test is irreconcilable with the mode of analysis³ set forth by the Supreme Court in *Whitman Saddle* and with the requirements of *KSR*.

3. Durling’s “So-Related” Requirement is Also Inconsistent with KSR

Durling’s “so-related” requirement is also inconsistent with *KSR*. This step is an even more rigid application of the rejected TSM test. Opening Brief at 21-22. It prohibits factfinders from even considering modifying a *Rosen* reference with another reference unless the secondary reference is “so related” and depicts the modification.

Even GM abandons *Durling*’s “so-related” requirement and emphasizes that *Glavas* only requires an “aesthetic or design-based reason for any proposed modification.” GM Response at 56. But even that reconstruction of the so-related

³ The Supreme Court’s mode of analysis is binding on the Federal Circuit. *Troy v. Samson Mfg. Corp.*, 758 F.3d 1322, 1326 (Fed. Cir. 2014). See also US Amicus Brief at 13, 24 n.4.

step is improper. The law cannot presume designers are mere automatons with no capability to envision anything beyond suggested aesthetic modifications. Designers consider factors other than aesthetics or designs alone. *See* Appx1332-1336 (Reply Decl. of Jason C. Hill) (automobile designers work with myriad inputs and constraints, including structural criteria, safety, aerodynamics, regulatory compliance, market pressure, trends and fashions, and brand identity). *Durling* Step Two forecloses consideration of designers’ experience, creativity, and common sense.⁴

As the Government agreed, *Durling* Step Two should be eliminated to allow the factfinder to evaluate all potentially relevant considerations that may weigh on the obviousness inquiry. US Amicus Brief at 12-13.

4. This Court Has Not Condoned Rigid Frameworks Post KSR

a. This Court Does Not Apply a Rigid Analogous Art “Test”

The so-called “analogous art” test is not rigidly restrictive and applies *Graham*’s directive to identify the scope and content of the prior art without restraint. Initially, the test created a shortcut for presuming that prior art within the same field of endeavor *was* within the scope of relevant prior art. *Application of Winslow*, 365

⁴ Contrary to the suggestions of GM and several amici, GM Response at 36, merely being the same type of product or falling under the same field of endeavor does not make a reference “so-related” under *Durling*.

F.2d 1017 (C.C.P.A. 1966). By 1971, the C.C.P.A. clarified that, even if not in the same field of endeavor, courts should still “presume that the inventor would have that ability to select and utilize knowledge from other arts *reasonably pertinent* to his particular problem which would be expected of a man of ordinary skill in the art to which the subject matter pertains.” *Application of Antle*, 444 F.2d 1168, 1171-72 (C.C.P.A. 1971). *See also In re Bigio*, 381 F.3d 1320, 1326 (Fed. Cir. 2004) (“[T]his test rests on an assessment of the nature of the application and claimed invention in addition to the level of ordinary skill in the art.”). Thus, the analogous art test would not exclude any prior art that a POSITA would have found obvious to consider. *See, e.g., In re Gleizer*, 356 F. App’x 415, 420 (Fed. Cir. 2009) (non-precedential) (“[T]he analysis need not seek out precise teachings directed to the specific subject matter of the challenged claim, for a court can take account of the inferences and creative steps that a person of ordinary skill in the art would employ.”) (quoting *KSR*, 550 U.S. at 418).

Consistent with *KSR*, the analogous art test embodies the “expansive,” “flexible,” and “functional” approach required by *Graham* and *Hotchkiss*.⁵ Indeed,

⁵ Similarly, “teaching away” is not a guardrail, but a factor considered in determining whether a claimed invention would have been obvious to a POSITA. *See DePuy Spine, Inc. v. Medtronic Sofamor Danek, Inc.*, 567 F.3d 1314, 1327-28 (Fed. Cir. 2009) (assessing obviousness by holistically analyzing relevant prior art references for everything that they suggested to a POSITA and the concerns they raised, and in light of the teachings of other relevant prior art).

this Court established after *KSR* that the analogous art test must not be read to impose a restriction on the obviousness inquiry. *See, e.g., Netflix, Inc. v. DivX, LLC*, 80 F.4th 1352, 1360 (Fed. Cir. 2023) (“Although [Appellant]... did not formulaically articulate a field of endeavor using those exact words, our precedent does not require the use of magic words. The Board erred by imposing a higher burden than that required by our precedent.”).

b. This Court Does Not Apply a Rigid Lead Compound “Test”

GM argues that the lead compound test is an example of a framework guiding the obviousness analysis that this Court has maintained after *KSR*. GM Response at 29-32. However, the development and subsequent unwinding of the lead compound test demonstrates the opposite trend-line: that test began as a shortcut for finding obviousness, was later transformed into a rigid and mandatory *Rosen*-like prerequisite to obviousness, and then was gutted of all substantive requirements in the wake of *KSR* because it ran afoul of *KSR*.

The lead compound test originated with *In re Dillon*, which held that in chemical compound cases, “structural similarity between claimed and prior art subject matter, proved by combining references or otherwise, where the prior art gives reason or motivation to make the claimed compositions, creates a *prima facie* case of obviousness.” 919 F.2d 688, 692 (Fed. Cir. 1990) (en banc) (Lourie, J.). This was not a prerequisite to considering obviousness, but a shortcut towards

establishing obviousness. Subsequently, *Yamanouchi Pharm. Co. v. Danbury Pharmacal, Inc.* departed from *Dillon* by requiring a lead compound and a showing of motivation to select that lead compound as a **prerequisite** to obviousness. 231 F.3d 1339, 1343-45 (Fed. Cir. 2000). *Yamanouchi* thus transformed *Dillon*'s general guidance into a rigid and mandatory rule, similar to how *Rosen* transformed *Jennings*' guidance that the obviousness analysis start with **something** into a rigid and mandatory prerequisite to obviousness.

This Court unwound *Yamanouchi*'s lead compound requirement after *KSR*, holding in *Takeda* that the lead compound test merely establishes that it was “necessary to identify some reason that would have led a chemist to modify a known compound in a particular manner to establish prima facie obviousness of a new claimed compound.” *Takeda Chem. Indus., Ltd. v. Alphapharm Pty., Ltd.*, 492 F.3d 1350, 1357 (Fed. Cir. 2007) (Lourie, J.). Since *Takeda*, the lead compound test has not imposed any requirements on what compound may be used, how similar that compound must be to the claimed compound, or how many lead compounds a party may assert **because** doing so would run afoul of *KSR*. See, e.g., *Altana Pharma AG v. Teva Pharms. USA, Inc.*, 566 F.3d 999, 1008 (Fed. Cir. 2009) (“[T]o the extent [appellant] suggests that the prior art must point to only a single lead compound for further development efforts, that restrictive view of the lead compound test would present a rigid test similar to the teaching-suggestion-motivation test that the

Supreme Court explicitly rejected in *KSR*.”). *See also Daiichi Sankyo Co. v. Matrix Lab’ys, Ltd.*, 619 F.3d 1346, 1352 (Fed. Cir. 2010) (“In keeping with the flexible nature of the inquiry after *KSR* ... the motivation to select and modify a lead compound need not be explicit in the art.”). And, consistent with *Dillon*, this Court has instructed lower courts that the lead compound analysis is optional. *See Otsuka Pharm. Co. v. Sandoz, Inc.*, 678 F.3d 1280, 1291-92 (Fed. Cir. 2012) (“*New compounds may be created from theoretical considerations rather than from attempts to improve on prior art compounds*”) (emphasis added).

II. THE APPROPRIATE TEST FOR EVALUATING DESIGN PATENT OBVIOUSNESS IS *GRAHAM* AS ELABORATED IN *KSR*

GM argued that applying the *Graham* factors would be a free-for-all with no analytical framework. GM Response, at 48. However, as the Supreme Court noted, “strict observance of the requirements laid down [in *Graham*] will result in that uniformity and definiteness which Congress called for in the 1952 Act.” *Graham*, 383 U.S. at 18.⁶ “While aspects of the obviousness inquiry ... may take on a slightly different focus or salience when applied to design patents, the fundamentals of that inquiry should be the same.” US Amicus Brief at 17-18 (articulating numerous reasoned parallels between the considerations invoked in utility patent cases and design patent cases).

⁶ Even the Intellectual Property Owner’s Association endorsed *Graham* as the appropriate replacement if *Rosen-Durling* was abrogated. Dkt. 171 at 12.

A. *Graham* Provides Sufficient Guidance

Applying *Graham* will not leave courts adrift or upset reliance interests. *See* GM Response at 54. The *Graham* test was applied successfully in design patent cases by nearly every other circuit while this Court’s predecessor was applying *Laverne*’s inappropriate “ordinary intelligent man” test. *See* Opening Brief at 57. The sky did not fall on design patents then, and it will not now.

Almost two decades since *KSR*, this Court and the PTAB have ample experience applying *KSR*’s flexible test in thousands of utility patent cases. They can apply the same approach to design patents.

B. Patent Examiners Would Not be Left Adrift

While the Government agreed that applying the *Graham* test as set forth in *KSR* is workable at the court level, it expressed concern that USPTO examiners would lack an adequate starting point and guidance about how to determine what the skilled designer would have found obvious. US Amicus Brief at 31. LKQ agrees that there must be some starting point. When challenging a claimed design under *KSR* and *Graham*, the examiner must articulate an apparent reason for why that design was obvious to a DOSA. *KSR*, 550 U.S. 398 at 418. This rationale for obviousness must start *somewhere*, and specifically, it must start where it would have made sense for a DOSA to start. That will probably, but not necessarily, be with a prior art reference, as the Supreme Court did in *Whitman Saddle*. USPTO

examiners are familiar with and skilled in application of the standards set forth in *KSR* and *Graham*, and they are eminently qualified to apply these standards to design patents. See UNITED STATES PATENT AND TRADEMARK OFFICE, BECOME A DESIGN PATENT EXAMINER (2023), <https://www.uspto.gov/jobs/become-design-patent-examiner> (qualifications required to become a design patent examiner). Indeed, examiners will be better able to evaluate obviousness with access to more evidence, rather than the very limited evidence to which they are now confined.

If the concern with applying *KSR* or *Graham* directly is that, without guidance, examiners will issue too many rejections, there are several protections in place in USPTO practice. First, examiners bear the ultimate burden of proving unpatentability. *In re Oetiker*, 977 F.2d 1443, 1444-46 (Fed. Cir. 1992); MPEP § 2142. Second, if they receive a rejection, applicants may articulate why the design is nonobvious and submit supporting evidence. MPEP § 2145. And with the creation of a design patent bar, the USPTO has invited more design expertise into the collaborative and non-adversarial process, which commentators indicate will improve the quality of design patent applications and prosecution. 37 C.F.R. §§ 1, 11, 41 (11/15/2023; eff. 01/02/2024).

Even if rigid rules are easier to apply than flexible and expansive multifactor tests, that does not make them lawful. In *KSR*, the appellee argued that the TSM test “provides the Patent Office the roadmap to establishing obviousness. Because TSM

somewhat objectifies the test for obviousness, it creates a target at which the Patent Office can aim.” Brief for Appellee at 39, *KSR*, No. 04-1350 (internal citations omitted). However, *KSR* rejected this argument and declined to replace TSM with other express guidance and instead reiterated the broad and flexible inquiry described by *Graham*. *KSR*, 550 U.S. at 415.

III. GM’S CLAIM THAT THE *ROSEN-DURLING* TEST HAS LONG WORKED IS MYOPIC AND WRONG

GM argues the flexibility of *Rosen-Durling* is demonstrated by this Court finding designs were obvious in 60% of post-*KSR* cases where it substantively evaluated obviousness, and that design patents’ extremely high grant rate is expected because they have “narrow scope.” See GM Response at 6, 41, 46. Not so.

GM’s argument that the grant rate is extremely high because design patents have “almost no scope” relies upon a misnomer.” See *MRC Innovations*, 747 F.3d at 1333, n.1 (design patents have scope); see also *In re Maatita*, 900 F.3d 1369, 1377 (Fed. Cir. 2018) (design patents can cover multiple embodiments). The more likely explanation for the disparity in grant rates, Opening Brief at 26-27 (**only 2%** of design patent applications prosecuted before the USPTO receive a prior-art-based rejection), is that the *Rosen-Durling* test shields obvious design patents from

rejection. Sarah Burstein & Saurabh Vishnubhakat, *The Truth About Design Patents*, 71 Am. U.L. Rev. 1221 (2022):

Crouch posited that the high design patent grant rate was a result of “the USPTO’s *sub silentio* abdication of its gatekeeper function in the realm of design patents.” But if such were the case, we would expect to see more design patents invalidated in court and in the PTAB.

...

Ultimately, it seems the most likely explanation is that the substantive standards of design patentability are extremely friendly to design patent owners and applicants.

GM’s remaining analysis focuses solely on this Court’s post-*KSR* decisions—less than fifteen in total—to the exclusion of all the other data demonstrating that design patent invalidation rates in the aggregate are far lower than utility patent invalidation rates. Opening Brief at 29-30 (before district courts, invalidation rate of 11.6% for design patents versus 46% for utility patents); *see also infra* at 25 (before the PTAB, 23.6% invalidation for design patents versus 59.1% for utility patents). The cases where this court found obviousness involved prior art nearly identical to the claimed design. *See* § I.B.2.b, *supra*. This is likely because design patent challengers only appeal extremely strong cases since they have the very heavy burden of proving that there was not substantial evidence to support the instinctive, factual determination that the *Rosen* reference was not basically the same. *See, e.g.,*

In re Jolley, 308 F.3d 1317, 1320, 1326, 1328 (Fed. Cir. 2002) (“substantial evidence” satisfied if any factual determination plausible under the evidence exists).

GM’s argument is further belied by its own counsel’s public statements. Craig Deutsch, Jennifer Huang, and Grace Kim, all involved in a PTAB determination that led to this appeal (PGR2020-00055, No. 22-1253), published an article and held a webinar on the disparity in difficulty of proving design patent obviousness before the PTAB versus utility patent obviousness.⁷ They stated that 60% of petitions for AIA trials of design patents before the PTAB end in denial of institution—a dispositive and unappealable final decision—versus 27% for utility patents. *Id.* When instituted, design patent challengers succeeded far less than utility patent challengers (59% versus 81%), yielding an aggregate success rate of 23.6% for design patent challengers, versus 59.1% for utility patent challengers. *See id.* at 1:

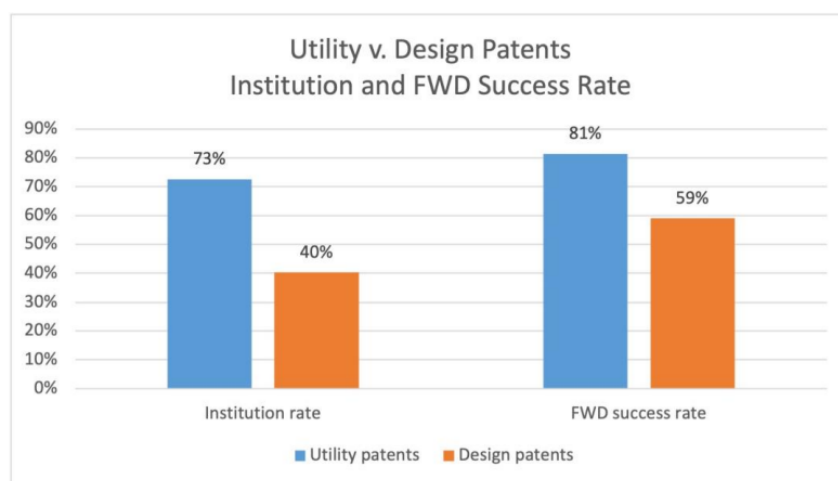

⁷ Deutsch, Craig, *et al.*, How to Succeed in Design Patent Cases at the PTAB, May 3, 2022, <https://www.fr.com/uploads/610-2022-05-03-article-law360-designpatentcasesattheptab-deutsch-huang-kim.pdf> (last accessed Nov. 28, 2023).

GM's attorney acknowledged the contribution of *Rosen-Durling* to this trend:

Historically, obviousness challenges before the PTAB have favored patent owners. In particular, petitioners have struggled to convince panels that prior art references qualify as *Rosen* references, ***reflecting a high bar in analyzing the first step of obviousness.*** In these cases, because the petitioner could not establish a proper *Rosen* reference, the PTAB's analysis did not move to the second obviousness inquiry.

Id. (emphasis added).⁸

The PTAB has applied *Rosen* when denying institutions despite extraordinary similarities between the reference and the patent:

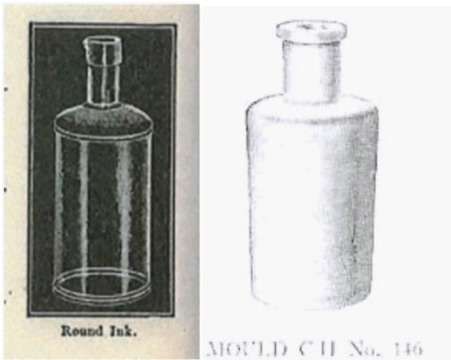
<i>Vitro Packaging, LLC v. Saverglass, Inc.</i> , No. IPR2015-00947, 2015 WL 5766302, at *1 (P.T.A.B. Sept. 29, 2015)	
CLAIMED DESIGN	REJECTED PRIOR ART REFERENCE(S)
 <p>FIG. 1 FIG. 2</p>	 <p>Round Ink. MOULD C H No. 146</p>

⁸ See also, <https://www.youtube.com/watch?v=ujNVECHoQy8> (A webinar given by the same attorney where he stated: “As a Petitioner you need to have very close art. This isn’t a situation where you can have a primary reference that has one feature and a secondary reference that has another feature and they’re combined to arrive at the claimed design where both the primary and secondary references are somewhat different. ***You really need a primary reference that gets you almost all of the way there*** and the secondary reference just coming in to tweak or add something on the design.”) (emphasis added).

Macsports, Inc. v. Idea Nuevo, Inc.,
 No. IPR2018-01006, Paper 6 (P.T.A.B. Nov. 13, 2018)

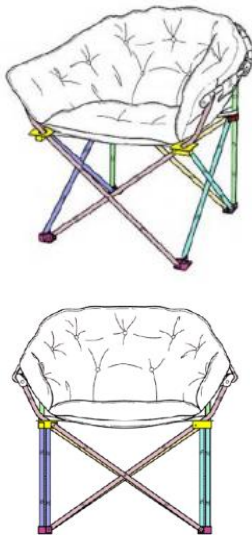
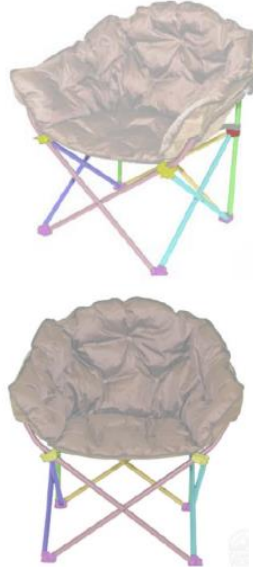
CLAIMED DESIGN	REJECTED PRIOR ART REFERENCE
	

LKQ Corp, et al v. GM Global Technology Operations LLC
 No. PGR2020-000005, Paper 11 (P.T.A.B. May 5, 2020)

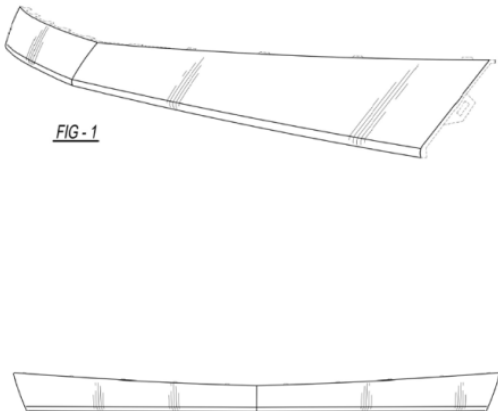
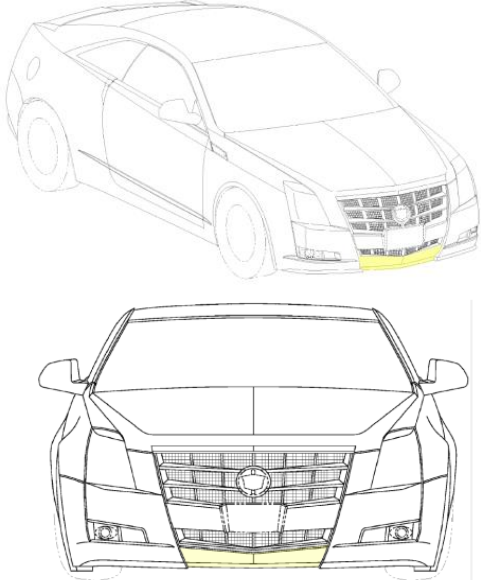
CLAIMED DESIGN	REJECTED PRIOR ART REFERENCE
	

Mere examination of images cannot substitute for analysis of what a designer would have found obvious. However, in all those cases, the Board stopped the analysis once it decided that two virtually identical things were not “basically the same,” and thus never considered whether a designer would have found the design obvious. And there was no opportunity for appeal.

IV. STARE DECISIS CUTS AGAINST RETAINING *ROSEN-DURLING* BECAUSE IT IS INCONSISTENT WITH CONTROLLING PRECEDENT

GM argued that *stare decisis* demands retaining *Rosen-Durling* because it has “been applied for decades” and “defines critical property rights,” and “it is usually more important that the [law] be settled than that it be settled right.” GM Response at 43-44. GM is wrong. *Stare decisis* demands that this Court recognize that *Rosen-Durling* was abrogated because it is contrary to the Supreme Court’s prior and subsequent precedents.

Stare decisis does not justify elevating this Court’s precedents above those of the Supreme Court. In fact, GM’s citation to *Lighting Ballast* demonstrates this point, as the Supreme Court **abrogated** *Lighting Ballast* less than a year after it was decided. *Stare decisis* demanded adherence to the Supreme Court’s precedents, not the Federal Circuit’s contrary precedent. *Teva Pharma. USA v. Sandoz, Inc.*, 574 U.S. 318, 324 (2015).

The *Rosen-Durling* test is subordinate to the Supreme Court’s precedents, including *KSR* and *Whitman Saddle*. Any post-*KSR* “reliance” on *Rosen-Durling* by

patent owners was misplaced. *KSR* itself put patent applicants and owners on notice that rigid and formulaic rules that protected patents on obvious designs were inappropriate. If there was any doubt, this Court’s foreshadowing of *KSR*’s likely applicability to design patents fifteen years ago should have dispelled it. *Titan Tire*, 566 F.3d at 1384-85.

Further, all patent cases impact property rights; not just design patent cases. Yet, the Supreme Court has repeatedly and systematically abrogated this Court’s rigid and formulaic tests despite their decades-long persistence. *See* Opening Brief at 54-56 (citing cases).

V. CONGRESS HAS NOT ENDORSED *ROSEN-DURLING*

Congress’ silence regarding design patent obviousness is not an endorsement of the *Rosen-Durling* test. *See Halo Elecs., Inc. v. Pulse Elecs., Inc.*, 579 U.S. 93, 108 (2016) (reenactment of the Patent Act with identical language in 2011 did not evince Congressional endorsement); *Cnty. for Creative Non-Violence v. Reid*, 490 U.S. 730, 749 (1989) (“Ordinarily, Congress’ silence is just that—silence.”). Likewise, the PARTS Act and SMART Act are not relevant to design patent obviousness.

VI. GM AND AMICI’S POLICY ARGUMENTS DO NOT SUPPORT GRANTING PATENTS ON OBVIOUS DESIGNS

GM and certain amici seem to argue that the award of design patents should be the rule, not the exception, and that design patents should help protect against

copying. This fundamentally misunderstands the nature and purpose of design patents: to protect *innovative* designs, *i.e.*, those that are novel and non-obvious. Designers certainly produce innovative and non-obvious designs, but they also produce ordinary, routine, and obvious designs. It is in the best interests of the public and of designers who create truly innovative and non-obvious designs for those designs to receive the benefit of a design patent monopoly, and *not* obvious designs.

Innovative designs can and should be protected by design patents. But not all designs are innovative. Most new products and designs do not meet the criteria required for patentability. *See* Standard Catalog of American Cars, 1976-1999, 3rd Edition, James M. Flammang and Ron Kowalke at 9 (“While it is true that many cars of this era were repetitive in design, lackluster in performance and difficult to tell apart, exceptions abounded.”). Further:

Some ideas in this space are easy to find because they are obvious, or they have been seen before in existing products. Other, less obvious ideas require more effort to identify. Ideally, this search for less obvious, more innovative ideas would entail visiting all feasible ideas in the design space. The resulting set of potential candidate designs is better informed by understanding more possibilities. However, both novice and experienced designers often struggle with identifying alternative designs (Ball et al. 2004). For novices in particular, limitations in technology or technical expertise make it difficult to generate multiple different ideas. Attempts at diverging from existing solutions may result in only minor tweaks to known designs, limiting the chances of innovation. Design fixation, or an attachment to the early ideas generated, has often been observed, and since early

ideas are only rarely successful, this leaves novice designers more likely to fail in creating innovative solutions.

Design Education Today: Technical Contexts, Programs and Best Practices 2019.

The design patent system is not a registration scheme, and a party is not entitled to a patent monopoly for an obvious design:

The patent monopoly was not designed to secure to the inventor his natural right in his discoveries. Rather, it was a reward, an inducement, to bring forth new knowledge. The grant of an exclusive right to an invention was the creation of society—at odds with the inherent free nature of disclosed ideas—and was not to be freely given.

Graham, 383 U.S. at 9. The public has an interest in the free exercise of ideas and competition in the market. *Sears, Roebuck & Co. v. Stiffel Co.*, 376 U.S. 225, 231 (1964) (“What Sears did was to copy Stiffel’s design and to sell lamps almost identical to those sold by Stiffel. This it had every right to do under the federal patent laws. ... Sharing in the goodwill of an article unprotected by patent or trade-mark is the exercise of a right possessed by all—and in the free exercise of which the consuming public is deeply interested.”) (citations and quotations omitted). Extending the scope of design patent protection to obvious subject matter for the express purpose of awarding unearned monopolies and stifling market competition is consistent neither with the public interest, nor the interests of designers creating innovative designs, nor the law.

CONCLUSION

Rosen-Durling should be replaced with the flexible and expansive test set forth in *KSR* and *Graham*.

Dated: November 29, 2023

Respectfully submitted,

By: /s/ Barry F. Irwin

Barry F. Irwin

Iftekhhar A. Zaim

Andrew C. Himebaugh

Ariel H. Katz

IRWIN IP LLP

150 N Wacker Dr., Suite 700

Chicago, IL 60606

(312) 667-6080

birwin@irwinip.com

izaim@irwinip.com

ahimebaugh@irwinip.com

akatz@irwinip.com

Mark A. Lemley

Mark P. McKenna

LEX LUMINA, PLLC

745 Fifth Avenue, Suite 500

New York, NY 10151

(646) 898-2055

mlemley@lex-lumina.com

mark@lex-lumina.com

Counsel for Appellants

LKQ Corporation and

Keystone Automotive Industries, Inc.

**UNITED STATES COURT OF APPEALS
FOR THE FEDERAL CIRCUIT**

CERTIFICATE OF COMPLIANCE WITH TYPE-VOLUME LIMITATIONS

Case Number: 2021-2348

Short Case Caption: LKQ Corporation, et al. v. GM Global Technology Operations LLC

Instructions: When computing a word, line, or page count, you may exclude any items listed as exempted under Fed. R. App. P. 5(c), Fed. R. App. P. 21(d), Fed. R. App. P. 27(d)(2), Fed. R. App. P. 32(f), or Fed. Cir. R. 32(b)(2).

The foregoing filing complies with the relevant type-volume limitation of the Federal Rules of Appellate Procedure and Federal Circuit Rules because it meets one of the following:

- the filing has been prepared using a proportionally-spaced typeface and includes 6,968 words.
- the filing has been prepared using a monospaced typeface and includes _____ lines of text.
- the filing contains _____ pages / _____ words / _____ lines of text, which does not exceed the maximum authorized by this court's order (ECF No. _____).

Date: 11/29/2023

Signature: /s/ Barry F. Irwin

Name: Barry F. Irwin