

2020-1009, -1034

**United States Court of Appeals
for the Federal Circuit**

OLAF SÖÖT DESIGN, LLC,

Plaintiff-Cross-Appellant,

– v. –

DAKTRONICS, INC.,

Defendant-Appellant.

*On Appeal from the United States District Court for the Southern
District of New York in No. 1:15-cv-05024-GBD-OTW*

**PETITION FOR REHEARING AND REHEARING *EN*
BANC ON BEHALF OF PLAINTIFF-CROSS-
APPELLANT**

JAMES M. BOLLINGER
MAGNUS ESSUNGER
KATHERINE HARIHAR
GERALD E. PORTER
TROUTMAN PEPPER HAMILTON
SANDERS LLP
875 Third Avenue
New York, New York 10022
(212) 704-6000
james.bollinger@troutman.com
magnus.essunger@troutman.com
katherine.harihar@troutman.com
gerald.porter@troutman.com

Counsel for Plaintiff-Cross-Appellant

CERTIFICATE OF INTEREST

Counsel for Olaf Sööt Design, LLC certifies the following:

1. The full name of every party represented by Troutman Pepper Hamilton Sanders LLP is: Olaf Sööt Design, LLC.
2. The name of the real party in interest represented Troutman Pepper Hamilton Sanders LLP is: N/a.
3. Parent corporations and publicly held companies that own 10% or more of stock in the party: None.
4. The names of all law firms and the partners or associates that appeared for the party or amicus now represented by me in the trial court or agency or are expected to appear in this court (and who have not or will not enter an appearance in this case) are: TROUTMAN PEPPER HAMILTON SANDERS LLP: James Bollinger, Magnus Essunger, Katherine Harihar, Gerald Porter, Timothy Heaton (no longer with firm), Phoenix Pak (no longer with firm), Puja Dave (no longer with firm), and Susan Grace (no longer with firm).
5. The title and number of any case known to counsel to be pending in this or any other court or agency that will directly affect or be directly affected by this court's decision in the pending appeal. See Fed. Cir. R. 47. 4(a)(5) and 47.5(b). (The parties should attach continuation pages as necessary): None besides this Federal Circuit Appeal (20-1009) and Cross-Appeal (20-1034).
6. All information required by Federal Rule of Appellate Procedure 26.1(b) and (c) that identifies organizational victims in criminal cases and debtors and trustees in bankruptcy cases: None.

Dated: February 22, 2021

/s/ James M. Bollinger

James M. Bollinger

TABLE OF CONTENTS

	Page
CERTIFICATE OF INTEREST	ii
STATEMENT OF COUNSEL PURSUANT TO FED. CIR. R. 35(b)(2)	1
I. INTRODUCTION	3
A. <i>En Banc</i> Review Is Necessary to Determine When, if Ever, a Party Can Waive a Claim Construction Dispute and Whether a “Plain and Ordinary” Claim Construction Is Ever Appropriate for Jury Consideration	4
1. Relevant factual background.....	4
2. <i>En banc</i> review is needed to determine under what circumstances appellate review of claim construction is ripe under O2 Micro.....	6
3. <i>En banc</i> review is needed to determine under what circumstances a plain and ordinary meaning dispute is an “actual” one within the meaning of O2 Micro.....	8
4. <i>En banc</i> review is needed to confirm a jury can determine if evidence satisfies a claim’s plain and ordinary meaning	11
B. The Panel Vitiating Determination Adopts a Binary Analysis Creating a New Legal Exception to the Doctrine of Equivalents	12
CONCLUSION.....	15
CERTIFICATE OF SERVICE	
CERTIFICATE OF COMPLIANCE	

TABLE OF AUTHORITIES

	Page(s)
Cases	
<i>ActiveVideo Networks, Inc. v. Verizon Commc’ns, Inc.</i> , 694 F.3d 1312 (Fed. Cir. 2012)	9
<i>Akamai Techs., Inc. v. Limelight Networks, Inc.</i> , 805 F.3d 1368 (Fed. Cir. 2015)	1, 6
<i>AMW Materials Testing, Inc. v. Town of Babylon</i> , 584 F.3d 436 (2d Cir. 2009)	14
<i>ATEN Int’l Co. v. Uniclass Tech. Co.</i> , 932 F.3d 1364 (Fed. Cir. 2019)	7
<i>Bio-Rad Labs., Inc. v. 10X Genomics Inc.</i> , 967 F.3d 1353 (Fed. Cir. 2020)	12
<i>Brilliant Instruments, Inc. v. GuideTech, LLC</i> , 707 F.3d 1342 (Fed. Cir. 2013)	14
<i>Broadcom Corp. v. Qualcomm Inc.</i> , 543 F.3d 683 (Fed. Cir. 2008)	7
<i>Cadence Pharm., Inc. v. Exela PharmSci Inc.</i> , 780 F.3d 1364 (Fed. Cir. 2015)	1, 12, 13, 14
<i>Core Wireless Licensing S.A.R.L. v. Apple Inc.</i> , 899 F.3d 1356 (Fed. Cir. 2018)	6, 7
<i>Deere & Co. v. Bush Hog, LLC</i> , 703 F.3d 1349 (Fed. Cir. 2012)	13, 14
<i>Eon Corp. IP Holdings LLC v. Silver Spring Networks, Inc.</i> , 815 F.3d 1314 (Fed. Cir. 2016)	10
<i>Exxon Chem. Patents, Inc. v. Lubrizol Corp.</i> , 137 F.3d 1475 (Fed. Cir. 1998)	12
<i>GPNE Corp. v. Apple Inc.</i> , 830 F.3d 1365 (Fed. Cir. 2016)	9

Hormel v. Helvering,
312 U.S. 552 (1941).....7

Huawei Techs. Co. v. T-Mobile US, Inc.,
No. 2:16-CV00052-JRG-RSP, 2017 WL 4070592 (E.D. Tex. Aug.
29, 2017)adopted, 2017 WL 4049251 (E.D. Tex. Sept. 13, 2017)8

Lazare Kaplan Int’l, Inc. v. Photocscribe Techs., Inc.,
628 F.3d 1359 (Fed. Cir. 2010)7

NobelBiz, Inc. v. Glob. Connect, L.L.C.,
701 Fed. App’x. 994 (Fed. Cir. 2017)10

NobelBiz, Inc. v. Glob. Connect, L.L.C.
876 F.3d 1326 (Fed. Cir. 2017)9, 10, 12

Nuance Communications, Inc. v. ABBYY USA Software House, Inc.,
813 F.3d 1368 (Fed. Cir. 2016)1, 6

O2 Micro Int’l Ltd. v. Beyond Innovation Tech. Co.,
521 F.3d 1351 (Fed. Cir. 2008)passim

Olaf Sööt Design, LLC v. Daktronics, Inc.,
220 F. Supp. 3d 458 (S.D.N.Y. 2016)4

Olaf Soot Design, LLC v. Daktronics, Inc.,
406 F. Supp. 3d 328 (S.D.N.Y. 2019)11

Summit 6, LLC v. Samsung Elecs. Co.,
802 F.3d 1283 (Fed. Cir. 2015)9

Union Carbide Chems. & Plastics Tech. Corp. v. Shell Oil Co.,
425 F.3d 1366 (Fed. Cir. 2005)9

Warner-Jenkinson Co. v. Hilton Davis Chem. Co.,
520 U.S. 17 (1997).....1

STATEMENT OF COUNSEL PURSUANT TO FED. CIR. R. 35(b)(2)

Based on my professional judgment, I believe the Panel decision is contrary to the following decision(s) of the Supreme Court of the United States or the precedent(s) of this Court:

O2 Micro Int'l Ltd. v. Beyond Innovation Tech. Co., 521 F.3d 1351 (Fed. Cir. 2008); *Nuance Communications, Inc. v. ABBYY USA Software House, Inc.*, 813 F.3d 1368 (Fed. Cir. 2016); *Akamai Techs., Inc. v. Limelight Networks, Inc.*, 805 F.3d 1368 (Fed. Cir. 2015); *Warner-Jenkinson Co. v. Hilton Davis Chem. Co.*, 520 U.S. 17 (1997); *Cadence Pharm., Inc. v. Exela PharmSci Inc.*, 780 F.3d 1364 (Fed. Cir. 2015).

Based on my professional judgment, I believe this appeal requires an answer to one or more precedent-setting questions of exceptional importance:

1. Whether *waiver* prevents a challenge to claim construction on appeal *sua sponte* where a party's waiver is based on the fact that the original claim construction was (i) sponsored by the party during *Markman*, (ii) accepted by the district court, and applied by the jury in reaching its verdict; and (iii) not challenged on appeal by either party. If not, what conditions must exist to overcome such waiver on claim construction.
2. Whether a "plain and ordinary meaning" claim construction is ever appropriate for jury instructions on infringement by the district court; and

if so, is it appropriate for simple, non-technical terms such as the element h and “hollow drum” at issue in this case.

3. Whether a jury verdict of infringement under the doctrine of equivalents can be reversed on vitiation grounds as a legal exception to equivalents that negates any requirement for deferential consideration of the substantial evidence supporting the verdict. If so, what are the circumstances that create a legal exception to equivalents by vitiation.

/s/ James M. Bollinger
Counsel for Cross-Appellants

I. INTRODUCTION

Rehearing and/or *en banc* rehearing is warranted as the Panel mistakenly applied *O2 Micro*. This error led to the Panel’s *sua sponte* claim construction of “element h” that “the claimed hollow hub is not a component of the claimed hollow drum.” Opinion¹ at 7. Procedurally, Appellant waived any such *O2 Micro* challenge to the district court’s claim construction by failing to challenge the construction at the district court or on appeal.² Substantively, the rejection of “plain and ordinary meaning” constructions of element h and the hollow drum removed non-technical, readily understood claim terms from the jury.

This error violates fundamental principles of appellate review and injects great uncertainty into the appellate process with respect to the *sua sponte* application of *O2 Micro* and related authorities on issues not before this Court. Without guidance, parties and district courts will expend significant resources on litigation and trial, while the specter of *O2 Micro* looms even when no “disputed” terms remain.

¹ “Opinion” refers to *Olaf Soot Design, LLC v. Daktronics, Inc.*, No. 2020-1009, 2021 WL 56546 (Fed. Cir. Jan. 7, 2021).

² Appellant received from the district court the precise constructions it had proposed for these terms during the *Markman* process. During oral argument before this Court, when asked directly whether *O2 Micro* was applicable or if there was claim construction dispute, Appellant’s counsel stated “... It’s not a claim construction issue. It’s plain and ordinary meaning.” Oral Arg. 4:38-4:45.

The Panel also creates great uncertainty regarding the existing legal framework governing claim *vitiatio*n by reverting to a binary *vitiatio*n analysis without addressing the substantial evidence accepted by the jury on “insubstantial differences” and “function, way, and result” analysis. The Panel’s new approach has resurrected *vitiatio*n as a legal “exception” to the doctrine of equivalents. Without guidance, future litigants and courts will be left at sea on when or where *vitiatio*n may be resolved without reviewing the underlying evidence demanded by the Supreme Court precedent. This exception further and improperly undermines and threatens to swallow the doctrine notwithstanding its Supreme Court roots.

Clarification of the limits of *O2 Micro*, the appellate review process, and rejection of this new exception to the doctrine is warranted and respectfully requested by the Panel and/or *en banc* Court.

A. *En Banc* Review Is Necessary to Determine When, if Ever, a Party Can Waive a Claim Construction Dispute and Whether a “Plain and Ordinary” Claim Construction Is Ever Appropriate for Jury Consideration

1. Relevant factual background

First, as to element h, the Panel mistakenly credits Appellant with “contend[ing] that the hub and drum are separate” as part of the *Markman* process. Opinion at 6. The record is clear that Appellant insisted that “no construction was necessary” for this element – and the district court explicitly adopted this approach – providing a plain and ordinary meaning construction. Appx836-837; *Olaf Sööt*

Design, LLC v. Daktronics, Inc., 220 F. Supp. 3d 458, 467–68 (S.D.N.Y. 2016).

This was not a case of the district court “fail[ing] to resolve the parties’ dispute as to the meaning of the claim” – this was Appellant receiving its requested plain and ordinary meaning construction.³ Appx116; *see*, Opinion at 6.

The Panel also failed to recognize that neither party challenged in this appeal the district court constructions given to the jury at trial. At no point during the trial below or on appeal did Appellant raise any dispute as to the construction of “element h” or the related “hollow drum” term – relying solely on its arguments using the “plain and ordinary meaning” construction it had earlier proposed to the district court. Appx836-837. The lack of any claim construction issue on appeal was clearly acknowledged by Appellant:

Chief Judge Prost: “We have an old case called *O2 Micro* ... plain and ordinary meaning wasn’t good enough where the heart of the dispute came down to claim construction and the claim construction should have been done. Did you ever, you knew this was part of the dispute in the case, did you ever seek a specific claim construction on plain and ordinary meaning?”

Appellant’s Counsel: “No Your Honor, we saw plain and ordinary meaning. We think this claim was very clear and it requires both a hollow hub and a hollow drum. Both of them to be sized, such that the hollow drum can receive the screw. That doesn’t seem like anything

³ Appellant offered “no construction necessary” on 6 of the 10 disputed terms (Hollow Drum, Elongated Hollow Drum, Hollow Hub Rotatably Journalled, Elongated Screw, Elongated Screw Having a First End Non-Rotatably Mounted, and Element H). *See e.g.*, Appx825-827, Appx836-837; *see generally*, Daktronics’ Response Claim Construction Brief, ECF No. 62 at 11-23. This allowed Appellant to pursue concurrent anticipation arguments before the Patent Trial and Appeal Board – a tactical decision that should now bind it.

that requires any construction, your Honors. I think the way that OSD is construing and as well as the district court just makes no sense in context.” Oral Arg.⁴ 2:50-3:39. (emphasis added).

...

Chief Judge Prost: “Is it *de novo* review because it’s vitiation or because you think its a claim construction dispute?”

Appellant’s Counsel: “It’s a legal issue, Your Honor. Vitiation ... *It’s not a claim construction issue. It’s plain and ordinary meaning.*” Oral Arg. 4:34-4:45. (emphasis added).

2. *En banc* review is needed to determine under what circumstances appellate review of claim construction is ripe under *O2 Micro*

As was the case in *Nuance Communications, Inc. v. ABBYY USA Software House, Inc.*, the district court at *Markman* found in Appellant’s favor by adopting the plain and ordinary meaning of the “element h” and “hollow drum” claim terms. 813 F.3d 1368, 1373 (Fed. Cir. 2016). The fact that after trial Appellant became dissatisfied with the application of its own proposed construction by the jury does not give rise to an *O2 Micro* violation. *Id.*; *Akamai Techs., Inc. v. Limelight Networks, Inc.*, 805 F.3d 1368, 1376 (Fed. Cir. 2015) (finding no *O2 Micro* error where “the parties agreed in the stipulation as to both the meaning and the scope of the term during claim construction”). This carries more weight here as neither party raised an *O2 Micro* issue on appeal. As the Court stated in *Core Wireless*:

⁴ “Oral Arg.” refers to the November 6, 2020 Oral Argument before this Court, available at: http://www.cafc.uscourts.gov/oral-argument-recordings?title=&field_case_number_value=20-1009&field_date_value%5Bvalue%5D%5Bdate%5D=.

It appears that a claim scope dispute went unresolved during the course of trial, which resulted in the experts presenting competing theories of claim construction to the jury. ... This court has made clear that “[w]hen the parties present a fundamental dispute regarding the scope of a claim term, it is the court's duty to resolve it.” *O2 Micro Int'l Ltd. v. Beyond Innovation Tech. Co.*, 521 F.3d 1351, 1362 (Fed. Cir. 2008). Neither party raised this issue on appeal, however, so we do not address it further.

Core Wireless Licensing S.A.R.L. v. Apple Inc., 899 F.3d 1356, 1363 n.1 (Fed. Cir. 2018).

Given this void, it was not for the Panel – a reviewing court – to *sua sponte* raise it and fundamentally alter the appellate process. *Hormel v. Helvering*, 312 U.S. 552, 556 (1941) (rule prohibiting considering on appeal argument not raised to the district court ensures that “parties may have the opportunity to offer all the evidence they believe relevant to the issues ... [and] in order that litigants may not be surprised on appeal by final decision there of issues upon which they have had no opportunity to introduce evidence”).

Instead, this Court has held that “litigants waive their right to present new claim construction disputes if they are raised for the first time after trial.” *Broadcom Corp. v. Qualcomm Inc.*, 543 F.3d 683, 694 (Fed. Cir. 2008) (quoting *Conoco, Inc. v. Energy & Env't Int'l, L.C.*, 460 F.3d 1349, 1359 (Fed. Cir. 2006)); *Lazare Kaplan Int'l, Inc. v. Photocscribe Techs., Inc.*, 628 F.3d 1359, 1376 (Fed. Cir. 2010) (finding waiver); *see also ATEN Int'l Co. v. Uniclass Tech. Co.*, 932 F.3d 1364, 1370 (Fed. Cir. 2019) (“It is the parties’ obligation to raise a dispute

regarding the proper scope of claims to the court. ... We therefore affirm the district court's denial of JMOL as to noninfringement.”).

The Panel’s application of *O2 Micro* authorizes appellate review to address issues not raised by Appellant below or on appeal. For the benefit of litigants and courts today and in the future, *en banc* consideration of this *O2 Micro* waiver issue is urgently needed.

3. *En banc* review is needed to determine under what circumstances a plain and ordinary meaning dispute is an “actual” one within the meaning of *O2 Micro*

A further tension is growing under *O2 Micro* as it relates to the use by district courts of “plain and ordinary meaning” for claim construction guidance to the jury.

O2 Micro problems are difficult to evaluate with any confidence during pretrial (or trial, for that matter) because it is frequently impossible to delineate between a pure claim construction argument and a noninfringement argument. Yet juries are summoned, trials are held, and verdicts are reached, only to have the case fall in the *O2Micro* trap on appeal. *See, e.g., NobelBiz, Inc. v. Glob. Connect, L.L.C.*, No. 2016-1104, 2017 WL3044641 (Fed. Cir. July 19, 2017). Short of holding both a jury trial and an identical bench trial in every patent case, there is not a clear path around *O2 Micro*.

Huawei Techs. Co. v. T-Mobile US, Inc., No. 2:16-CV00052-JRG-RSP, 2017 WL 4070592, at *1 (E.D. Tex. Aug. 29, 2017), *adopted*, 2017 WL 4049251 (E.D. Tex. Sept. 13, 2017).

The disputed terms in this case – a hollow drum with its endcap and hub – are well within the ambit of jury understanding. Under similar facts, “this Court

has found that when a term is non-technical and within the ken of an average juror, there is no actual dispute under *O2 Micro*, and therefore no need for court intervention.” *NobelBiz, Inc. v. Glob. Connect, L.L.C.* 876 F.3d 1326, 1328 (Fed. Cir. 2017) (O’Malley, J., dissenting from denial of rehearing *en banc*) (collecting cases, *GPNE Corp. v. Apple Inc.*, 830 F.3d 1365, 1371–73 (Fed. Cir. 2016) (finding no *O2 Micro* violation where the district court declined to construe the term “pager,” and determining that the real dispute was about allowing the defendant “to make certain arguments to the jury”); *Summit 6, LLC v. Samsung Elecs. Co.*, 802 F.3d 1283, 1291 (Fed. Cir. 2015) (finding that the district court did not err in declining to construe the disputed term, which was itself “comprised of commonly used terms; each is used in common parlance and has no special meaning in the art”); *ActiveVideo Networks, Inc. v. Verizon Commc’ns, Inc.*, 694 F.3d 1312, 1326 (Fed. Cir. 2012) (finding that the district court did not err under *O2 Micro* in concluding that “superimposing” claim terms “have plain meanings that do not require additional construction”); *see also Union Carbide Chems. & Plastics Tech. Corp. v. Shell Oil Co.*, 425 F.3d 1366, 1377 (Fed. Cir. 2005) (“Because the claim language does not require a particular form of testing, this inquiry is not a claim construction question, which this court reviews *de novo*. Rather, this court reviews this inquiry as a question of fact.”), *overruled on other*

grounds by Cardiac Pacemakers, Inc. v. St. Jude Med., Inc., 576 F.3d 1348 (Fed. Cir. 2009)).

At other times, however, this Court has found that such a construction leaves the scope of the claims unanswered. *See, e.g., NobelBiz, Inc. v. Glob. Connect, L.L.C.*, 701 Fed. App'x. 994, 997-999 (Fed. Cir. 2017); *Eon Corp. IP Holdings LLC v. Silver Spring Networks, Inc.*, 815 F.3d 1314, 1319–20 (Fed. Cir. 2016) (finding that the district court erred by instructing the jury that the terms “portable” and “mobile” should be given their plain and ordinary meanings). This dichotomy has become a well-recognized trap at the trial level. Judge O’Malley described the dichotomy in her dissent from the denial of rehearing *en banc* in *NobelBiz, Inc. v. Glob. Connect, L.L.C.*:

O2 Micro’s general rule is easy enough to state in the abstract: “When . . . parties raise an actual dispute regarding the proper scope of the[]claims, the court, not the jury, must resolve that dispute.” *O2 Micro*, 521 F.3d at 1360. We have not articulated, however, what constitutes an “actual dispute” in this context. While we expect district courts to distinguish *bona fide* infringement arguments from those masquerading as claim construction disputes, we have not provided the lower courts with effective guidance to do so. As a result, courts have struggled to strike the delicate balance between ensuring that they do not permit the jury to determine claim scope, on the one hand, and ensuring that they do not encroach upon the constitutionally mandated function of the jury to find facts, on the other.

876 F.3d at 1327-28.

Given that no technical or complex terms are at issue in this case, a fact both parties accept, the Panel’s rejection of Appellant’s agreed-to plain and ordinary

meaning claim construction – a construction accepted by both parties at trial – was beyond the scope of *O2 Micro*'s reach. This ruling at the very least, reflects the critical need for clarification so that future courts can identify the circumstances a plain and ordinary meaning dispute is an “actual” one within the meaning of *O2 Micro*, authorizing its application on appeal. This case presents the opportunity for this Court to clarify the confusion prior authority has created.

4. *En banc* review is needed to confirm a jury can determine if evidence satisfies a claim's plain and ordinary meaning

The Panel's decision undermines the fact-finding role of the jury. Following a two-week trial, the district court judge referred the question of infringement to the jury. The jury resolved the parties' factual disputes and determined infringement. The infringement decision was confirmed by a separate district court judge after a *de novo* review.⁵ Nonetheless, no deference was provided to any of the jury's findings of fact as to infringement – nor to the district court's fact finding regarding claim constructions (or independent confirmation thereafter).

Instead the Panel turned “what is a fundamentally factual question for the jury regarding whether the accused systems and features infringe the patent claims

⁵ After Judge Robert W. Sweet passed away in March 2019, the case was reassigned to Judge George B. Daniels. Judge Daniels undertook a *de novo* review post-verdict – and, after extensive briefing and a full-day hearing, issued a 35-page Opinion, again rejecting each of Daktronics' arguments. Appx12-50; see *Olaf Soot Design, LLC v. Daktronics, Inc.*, 406 F. Supp. 3d 328, 334 (S.D.N.Y. 2019).

into a legal one for the court – and ultimately itself – to resolve.” *NobelBiz*, 876 F.3d at 1328 (O’Malley, J., dissenting from denial of rehearing *en banc*). By relying on *O2 Micro* to support its holding, the Panel has exacerbated the growing confusion regarding the scope of that decision – and intruded on the jury’s fact-finding role. *Id.* Guidance *en banc* about *O2 Micro*’s reach is much-needed.

In addition, reversing the jury verdict on a claim construction issue that was never raised or briefed presents serious due process issues, as Appellee was never given an opportunity to address waiver or its infringement case in the context of the new construction by the Panel. *See Exxon Chem. Patents, Inc. v. Lubrizol Corp.*, 137 F.3d 1475, 1478 (Fed. Cir. 1998).

B. The Panel Vitiating Determination Adopts a Binary Analysis Creating a New Legal Exception to the Doctrine of Equivalents

This Court has repeatedly affirmed the proposition that “[v]itiating’ is not an exception or threshold determination that forecloses resort to the doctrine of equivalents but is instead a legal conclusion of a lack of equivalence based on the evidence presented and the theory of equivalence asserted.” *Cadence Pharm., Inc. v. Exela PharmSci Inc.*, 780 F.3d 1364, 1370 (Fed. Cir. 2015) (collecting cases); *Bio-Rad Labs., Inc. v. 10X Genomics Inc.*, 967 F.3d 1353, 1360 (Fed. Cir. 2020).

The Panel has injected new confusion in this settled law in finding that the jury’s verdict vitiated element h of the claim 27. Specifically, the Panel recognized that the accused winch’s hollow *hub* “receive[d] the screw” but, by ruling that the

hub is not part of the hollow drum as a matter of claim construction, the accused winch's *hollow drum* does not "receive the screw." Relying on this single finding regarding the literal correspondence between the claim and accused product, the Panel concluded that the foregoing *vitiating* element h and its requirement that the hollow drum is "sized" to "receive the screw" thereby applying the same test on equivalents as used to assess literal correspondence. Opinion at 10.⁶

This is precisely the binary approach this Court has warned against with respect to the *vitiating* analysis. *Deere & Co. v. Bush Hog, LLC*, 703 F.3d 1349, 1356-57 (Fed. Cir. 2012) ("Courts should be cautious not to shortcut this inquiry by identifying a 'binary' choice in which an element is either present or 'not present.'"); *Cadence Pharm.*, 780 F.3d at 1370. This Court has specifically rejected a repeat of the literal infringement analysis to resolve infringement by equivalents, noting that "the proper inquiry for the court is to apply the doctrine of equivalents, asking whether an asserted equivalent represents an 'insubstantial difference' from the claimed element, or 'whether the substitute element matches the "function," "way," and "result" of the claimed element.'" *Brilliant Instruments*,

⁶The Jury applied a plain and ordinary meaning construction, and on literal correspondence, it reached the same conclusion as the Panel finding that the accused winch did not literally include a hollow drum that "received the screw." This finding – matching the Panel and consistent with the Panel's new construction – ordinarily would preclude the *legal* dismissal of the jury verdict on equivalents absent review of the substantial evidence supporting that verdict as there is no evidence that the jury applied an incorrect claim construction.

Inc. v. GuideTech, LLC, 707 F.3d 1342, 1349 (Fed. Cir. 2013); *Deere & Co.*, 703 F.3d at 1356-57.

Given a jury verdict, the appropriate starting point in assessing vitiation on appeal was with the evidence before the jury and relied on in it reaching its verdict. Where the factfinder concludes that a product is “insubstantially different from that recited in the claim” as the jury did in this case, “the argument that a claim limitation is vitiated by the district court’s application of the doctrine of equivalents is both incorrect and inapt.” *Cadence Pharm.*, 780 F.3d at 1372. To reverse this verdict, settled authority limits appellate review to weighing the evidence before the jury regarding the function, way, and result comparisons, with all inferences against appellant and all credibility assessments in favor of the verdict.

A jury verdict may be disturbed only when there is “such a complete absence of evidence supporting the verdict that the jury’s findings could only have been the result of sheer surmise and conjecture, or there is such an overwhelming amount of evidence in favor of the movant that reasonable and fair minded men could not arrive at a verdict against him.” *AMW Materials Testing, Inc. v. Town of Babylon*, 584 F.3d 436, 456 (2d Cir. 2009).

CONCLUSION

This Court should grant the petition for panel rehearing or rehearing *en banc*, to address the growing confusion surrounding its *O2 Micro* authority and its subsequent application on waiver, claim construction and vitiation issues.

Dated: February 22, 2021

Respectfully submitted,

/s/ James M. Bollinger

James M. Bollinger

Magnus Essunger

Katherine Harihar

Gerald E. Porter

TROUTMAN PEPPER HAMILTON

SANDERS LLP

875 Third Avenue

New York, New York 10022

(212) 704-6000

*Attorneys for Plaintiff-Cross-Appellant
Olaf Soot Design, LLC*

ADDENDUM

NOTE: This disposition is nonprecedential.

**United States Court of Appeals
for the Federal Circuit**

OLAF SOOT DESIGN, LLC,
Plaintiff-Cross-Appellant

v.

DAKTRONICS, INC.,
Defendant-Appellant

2020-1009, 2020-1034

Appeals from the United States District Court for the Southern District of New York in No. 1:15-cv-05024-GBD-OTW, Judge George B. Daniels.

Decided: January 7, 2021

JAMES M. BOLLINGER, Troutman Pepper Hamilton Sanders LLP, New York, NY, argued for plaintiff-cross-appellant. Also represented by MAGNUS ESSUNGER, KATHERINE HARIHAR, GERALD EAMES PORTER, PHOENIX PAK.

KENNETH BRESSLER, Blank Rome LLP, New York, NY, argued for defendant-appellant. Also represented by DOMINGO M. LLAGOSTERA, RUSSELL T. WONG, Houston, TX.

Before PROST, *Chief Judge*, LOURIE and REYNA, *Circuit Judges*.

Opinion for the court filed by *Chief Judge* PROST, in which LOURIE and REYNA, *Circuit Judges*, join.

Additional views filed by *Circuit Judge* LOURIE.

PROST, *Chief Judge*.

Olaf Sööt Design, LLC (“OSD”) sued Daktronics, Inc. (“Daktronics”), alleging that Daktronics’s Vortek product infringes claim 27 of U.S. Patent No. 6,520,485 (“the ’485 patent”). Four of the eight elements of claim 27—elements b, d, e, and h—were tried to a jury, which ultimately found that the Vortek product met each of these elements under the doctrine of equivalents. After the jury verdict, Daktronics moved for judgment as a matter of law (“JMOL”) of noninfringement. Daktronics argued that the Vortek product did not meet element h either literally or under the doctrine of equivalents. The district court denied this motion. *See Olaf Sööt Design, LLC v. Daktronics, Inc.*, 406 F. Supp. 3d 328, 338 (S.D.N.Y. 2019) (“*Decision Denying JMOL*”). Daktronics appealed the final judgment of infringement and several additional rulings. OSD cross-appealed the district court’s judgment of no willful infringement and denial of OSD’s motion for an exceptional-case determination and attorneys’ fees. We have jurisdiction under 28 U.S.C. § 1295(a)(1).

We reverse the final judgment of infringement, moot-ing the remainder of Daktronics’s appeal and OSD’s cross-appeal.

BACKGROUND

I

The ’485 patent discloses a theater winch for moving scenery and lighting by winding and unwinding cables, which are attached to the scenery, around a drum.

'485 patent col. 3 ll. 41–51. An embodiment of the winch described by the '485 patent is shown below. The winch is a “zero fleet angle winch,” which means that the cables wind and unwind together without tangling and are maintained perpendicular to the drum. *Id.* at col. 4 ll. 14–29. The winch achieves zero fleet angle via movement of cable drum 11 laterally along carriage 40 as cable drum 11 ro-

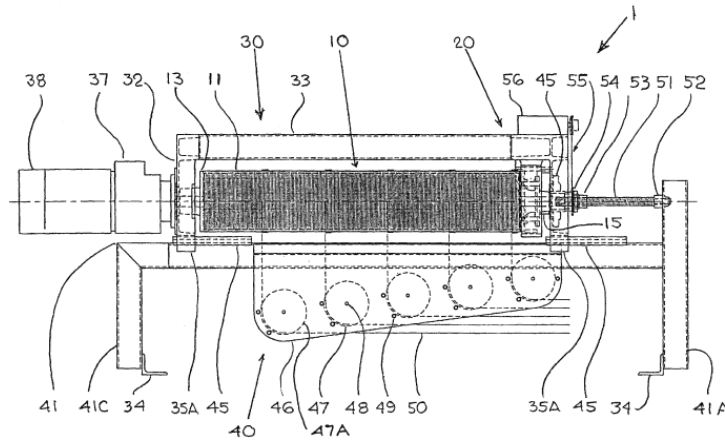

FIG 7

tates, permitting cables 50 to wind and unwind uniformly and preventing the cables from winding on themselves. *Id.* at col. 4, ll. 14–29.

More specifically, “nut 53 is non-rotatably mounted to the drum assembly 10 brake end cap 14 elongated hub.” *Id.* at col. 4 ll. 38–40. A motor rotates drum 11 and the mounted nut around fixed screw 51, which causes the nut to engage with and rotate around fixed screw 51. *Id.* at col. 4, ll. 30–60. Such engagement causes the nut and drum 11 to move laterally along carriage 40. *Id.* at col. 4, ll. 30–60. As drum 11, the elongated hub, and the nut move laterally, “the screw 51 can pass, via the hollow hub, inside the drum 11, which is also hollow.” '485 patent col. 4 ll. 40–41. Advantages of this setup include that “the screw 51 is protected” inside drum 11 and that the “overall length (its long

dimension) of the winch 1” is reduced. *Id.* at col. 4, ll. 41–42, 47–49.

Claim 27—the only claim at issue on appeal—recites:

27. A motorized fly system winch, drum and carriage combination for raising and lowering an object, comprising:

- a) a carriage,
- b) a base member having first and second end portions,
- c) an elongated hollow drum having cable grooves and having a longitudinal axis and rotatably mounted on the base member and a cable for simultaneously winding and unwinding the cable on or off the drum grooves when the drum is rotated, said cable passing from the outside of the drum directly or via a sheave to the object such that rotation of the drum causes the object to move up and down,
- d) first means for slideably mounting the base member to the carriage,
- e) said drum having at a first end a hollow hub rotatably journaled at the first end portion of the base member,
- f) second means for rotating the drum relative to the base member such that the base member with its drum and the carriage can move with respect to each other in synchronism with the rotation of the drum to control the cable run to the object,
- g) said second means comprising an elongated screw having a first end non-rotatably mounted to the carriage and a second end connected to the drum and axially aligned with the hollow hub and the hollow drum, said screw extending mainly outside of the hollow drum when the cable is wound up

on or unwound from the drum and the object is in its respective up or down position,

h) said hollow hub and hollow drum being sized such that the screw can move into the hollow hub to allow the hollow drum to receive the screw as the cable unwinds from or winds up on the drum as the object moves to its respective down or up position.

(emphasis added).

II

The relevant portion of Daktronics's Vortek product is depicted below. As shown, *see* Cross-Appellant's Br. 16, the internal passage for the screw ends within the hub, approximately two inches from the inside of the wider grooved drum member that receives and engages with the cables.

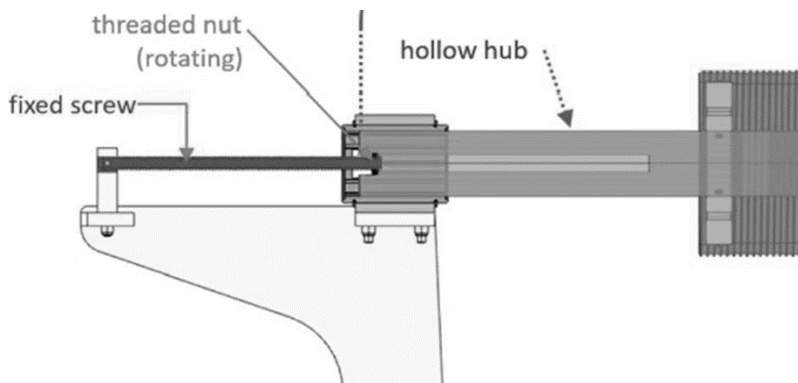

DISCUSSION

We conclude that the Vortek product does not infringe claim 27 of the '485 patent as a matter of law and thus reverse the final judgment of infringement. This holding moots the remainder of Daktronics's appeal and OSD's cross-appeal.

I

In *O2 Micro International Ltd. v. Beyond Innovation Technology Co.*, we explained that “[w]hen the parties present a fundamental dispute regarding the scope of a claim term, it is the court’s duty to resolve it.” 521 F.3d 1351, 1362 (Fed. Cir. 2008). Otherwise, a legal question will be “improperly submitted to the jury.” *Id.*

Here, the district court failed to resolve a fundamental dispute regarding the scope of claim element h—specifically, whether the hub is part of the drum.

OSD argued in its claim construction briefing that “the hub is a part of the drum.” J.A. 415. Because it is undisputed that the Vortek hub is able to receive the screw, under OSD’s interpretation of element h that the hub is part of the drum, it would necessarily follow that the Vortek drum would be able to receive the screw, as element h requires.

Daktronics, on the other hand, contended that the hub and drum are separate and that OSD was attempting to “drop[] the [claim] requirement that the drum receives the screw.” J.A. 836. Because it is undisputed that the Vortek screw is received by the hub and not the wider grooved drum member that receives the cables, under Daktronics’s interpretation of element h that the hub is not part of the drum, the Vortek drum would not receive the screw, as element h requires.

In its *Markman* order, the court stated that “[n]o construction of [element h] is necessary” and failed to resolve the parties’ dispute as to the meaning of the claim. *Olaf Sööt Design, LLC v. Daktronics, Inc.*, 220 F. Supp. 3d 458, 467–68 (S.D.N.Y. 2016). The court did not otherwise resolve this claim construction dispute prior to the jury trial. This failure violates *O2 Micro*.

The district court belatedly resolved the claim construction dispute in its post-jury-verdict decision denying

JMOL of noninfringement. Specifically, the district court concluded that the hub is part of the drum and, on that basis, rejected Daktronics's argument that the Vortek product does not infringe as a matter of law because the Vortek drum does not receive the screw. *Decision Denying JMOL*, 406 F. Supp. 3d. at 340–41. The district court explained that “the jury relied on ample evidence that the hollow drum and the hollow hub are not separate entities for purposes of receiving the screw.” *Id.* at 342. That claim construction dispute was for the judge to decide, not the jury. The district court's failure to resolve this material claim construction dispute prior to trial resulted in a claim construction dispute being “improperly submitted to the jury.” *O2 Micro*, 521 F.3d at 1362.

II

In *O2 Micro*, “[b]ecause we determine[d] that the district court [was] in the best position to determine the proper construction of the claim in the first instance,” we did not resolve the claim construction dispute in the first instance and instead remanded for further proceedings. *Id.* at 1362–63, 1366. Here, however, because we have the benefit of the district court's belated claim construction, and because the parties have briefed the dispute, no remand is necessary. We agree with Daktronics that, with respect to claim 27, the claimed hollow hub is not a component of the claimed hollow drum.

“The proper construction of a patent's claims is an issue of Federal Circuit law.” *Powell v. Home Depot U.S.A., Inc.*, 663 F.3d 1221, 1228 (Fed. Cir. 2011). “The construction of claim terms based on the claim language, the specification, and the prosecution history are legal determinations.” *Trs. of Columbia Univ. v. Symantec Corp.*, 811 F.3d 1359, 1362 (Fed. Cir. 2016) (citing *Teva Pharms. USA, Inc. v. Sandoz, Inc.*, 574 U.S. 318, 328 (2015)).

Claim terms “are generally given their ordinary and customary meaning,” which “is the meaning that the term

would have to a person of ordinary skill in the art in question at the time of the invention.” *Phillips v. AWH Corp.*, 415 F.3d 1303, 1312–13 (Fed. Cir. 2005) (en banc). “[T]he claims themselves provide substantial guidance as to the meaning of particular claim terms.” *Id.* at 1314. “[T]he person of ordinary skill in the art is deemed to read the claim term not only in the context of the particular claim in which the disputed term appears, but in the context of the entire patent, including the specification.” *Id.* at 1313. Although claim terms are interpreted in the context of the entire patent, it is improper to “read[] limitations from the specification into the claim.” *Id.* at 1323. “[T]he line between construing terms and importing limitations can be discerned with reasonable certainty and predictability if the court’s focus remains on understanding how a person of ordinary skill in the art would understand the claim terms.” *Id.*

Element h of claim 27 recites, in relevant part, that the “hollow hub and hollow drum [are] sized such that the screw can move into the hollow hub to allow the hollow drum to receive the screw.” This language makes clear that the hollow hub is not part of the hollow drum. The claim language treats the hub and drum as two components, reciting that both “the hollow hub *and* hollow drum” are sized to receive the screw. Furthermore, it would make no sense for the hollow hub to be part of the hollow drum given that the claim says that the screw moves into the hollow hub “*to allow* the hollow drum to receive the screw.” That language indicates that the screw’s entry into one component, the hollow hub, *facilitates* entry of the screw into another component, the hollow drum, not that entry into the hollow hub *is* entry into the hollow drum. In sum, the clearest reading of the claim language is that the hollow hub is not a component of the drum.

The specification confirms this conclusion. In particular, the specification explains that the “hub is hollow so that the screw 51 can pass, via the hollow hub, inside the

drum 11, which is also hollow.” ’485 patent col. 4 ll. 39–41. This passage confirms that the screw enters the drum via passage through another component, the hollow hub. And, after explaining that the hub is hollow, the passage continues treating the hub and drum as separate components by disclosing that the drum is “also” hollow.

OSD contends that the hub is part of the drum. In support, OSD argues that element e of claim 27—which recites “said drum having at a first end a hollow hub”—confirms that the hub is a component of the drum. We disagree. Element e merely specifies that the hollow hub is positioned at one of the ends of the drum.

OSD also points to the specification’s explanation that “the grooved cable drum 11 can be constructed of one tubular member 12, one drive end cap 13 and one brake end cap 14, all welded together,” *id.* at col. 5 ll. 7–9, and that the hub is “part of the cable drum 11 brake end cap 14,” *id.* at col. 3 ll. 59–61. However, this language is permissive, not mandatory: at most, this passage explains that the hub *can* be part of the drum, not that the hub *is* part of the drum. And the specification passage discussed previously contemplates embodiments in which the hub is not considered part of the drum. *See id.* at col. 4 ll. 39–41. For these reasons, and because claim 27 indicates that the hub is not part of the drum, we are not persuaded by OSD’s reliance on this passage of the specification.¹

Accordingly, we conclude that, for purposes of claim 27, the hub is not part of the drum.

¹ We note that “[i]t is not necessary that each claim read on every embodiment.” *Baran v. Med. Device Techs., Inc.*, 616 F.3d 1309, 1316 (Fed. Cir. 2010).

III

Under the proper construction, the Vortek product does not infringe claim 27 either literally or under the doctrine of equivalents. The Vortek product does not literally meet element h of claim 27 because the hollow drum of the Vortek is not able to receive the screw.

In addition, we conclude as a matter of law that the Vortek product does not meet element h under the doctrine of equivalents. The Vortek drum is unable to receive the screw, and the Vortek product has no equivalent function. Thus, a finding of infringement under the doctrine of equivalents would be inappropriate under these specific circumstances because such a finding would impermissibly eliminate the requirement that the hollow drum be able to receive the screw as the cable winds or unwinds on the drum. *See, e.g., Warner-Jenkinson Co. v. Hilton Davis Chem. Co.*, 520 U.S. 17, 29 (1997) (“[T]he application of the doctrine [of equivalents], even as to an individual element, is not allowed such broad play as to effectively eliminate that element in its entirety.”); *Power Integrations, Inc. v. Fairchild Semiconductor Int’l, Inc.*, 843 F.3d 1315, 1344–45 (Fed. Cir. 2016) (rejecting a theory of infringement under the doctrine of equivalents that would vitiate a claim limitation by rendering it meaningless); *Freedman Seating Co. v. Am. Seating Co.*, 420 F.3d 1350, 1358 (Fed. Cir. 2005) (concluding that “an element of an accused product or process is not, as a matter of law, equivalent to a limitation of the claimed invention if such a finding would entirely vitiate the limitation”); *Pfizer, Inc. v. Teva Pharms., USA, Inc.*, 429 F.3d 1364, 1379 (Fed. Cir. 2005) (“The all limitations rule ‘provides that the doctrine of equivalents does not apply if applying the doctrine would vitiate an entire claim limitation.’” (quoting *Asyst Techs., Inc. v. Emtrak, Inc.*, 402 F.3d 1188, 1195 (Fed. Cir. 2005))).

OLAF SOOT DESIGN, LLC v. DAKTRONICS, INC.

11

CONCLUSION

We have considered OSD's remaining arguments but find them unpersuasive. For the foregoing reasons, we conclude that the Vortek product does not infringe claim 27 of the '485 patent, and we therefore reverse the final judgment of infringement. In view of this conclusion, we dismiss the remainder of Daktronics's appeal and the entirety of OSD's cross-appeal as moot.

REVERSED-IN-PART AND DISMISSED-IN-PART

NOTE: This disposition is nonprecedential.

**United States Court of Appeals
for the Federal Circuit**

OLAF SOOT DESIGN, LLC,
Plaintiff-Cross-Appellant

v.

DAKTRONICS, INC.,
Defendant-Appellant

2020-1009, 2020-1034

Appeals from the United States District Court for the Southern District of New York in No. 1:15-cv-05024-GBD-OTW, Judge George B. Daniels.

LOURIE, *Circuit Judge*, additional views.

I concur in the panel's decision and fully agree with its reasoning as set forth in Chief Judge Prost's opinion. I write these separate comments to express concern over the use of the doctrine of equivalents to find infringement when four claim limitations have not literally been met by the accused device.

Infringement under our law is basically determined by whether the accused device, or process, or compound, meets the claims of the patent. That is literal infringement, the usual situation in patent litigation. We do have a doctrine of equivalents, which is clearly part of our law.

Graver Tank & Mfg. Co. v. Linde Air Prods. Co., 339 U.S. 605 (1950); *Festo Corp. v. Shoketsu Kinzoku Kogyo Kabushiki Co.*, 535 U.S. 722 (2002); *Eli Lilly & Co. v. Hospira, Inc.*, 933 F.3d 1320 (Fed. Cir. 2019). But almost always when an equivalence issue arises, it is with respect to one, or perhaps two, claim limitations.

Equivalence requires meeting the function-way-result test, or the insubstantial differences test, or both. See *Warner-Jenkinson Co. v. Hilton Davis Chem. Co.*, 520 U.S. 17, 40 (1997) (“Different linguistic frameworks may be more suitable to different cases, depending on their particular facts.”). But the Supreme Court has cautioned that the application of these tests requires “a special vigilance against allowing the concept of equivalence to eliminate completely any such elements” that are not literally met. *Id.* In short, in applying the doctrine of equivalents, judges and juries must use common sense.

I have previously noted that in the pharmaceutical industry it is quite possible that two compounds might satisfy the function-way-result test even though they are not equivalent on a structural, or identity, basis. See *Mylan Institutional LLC v. Aurobindo Pharma Ltd.*, 857 F.3d 858, 869 (Fed. Cir. 2017) (noting that the substantially different compounds aspirin and ibuprofen could be considered to have the same function, way, and result). In such a case, the law should not be so rigid as to restrain a factfinder from recognizing the clear lack of equivalence.

Similarly, common sense must be applied to the insubstantial differences test. Having multiple differences from the claim should be a hallmark of noninfringement. It fails the straight face test to assert that the accused subject matter does not meet the claims in multiple distinct ways, but infringes anyway.

Here, we have four claim limitations that are not met literally. I have found no case in which we have affirmed a finding of infringement under the doctrine of equivalents

when four separate claim limitations are not met literally. That would be equivalent (no pun intended) to holding that the accused product infringes when it does not infringe. We have a concept in patent law of “inventing around,” and that is considered socially desirable for the promotion of competition and the benefit of consumers. *See, e.g., Westvaco Corp. v. Int’l Paper Co.*, 991 F.2d 735, 745 (Fed. Cir. 1993); *State Indus., Inc. v. A.O. Smith Corp.*, 751 F.2d 1226, 1235–36 (Fed. Cir. 1985). To find that multiple significant instances of inventing around still infringe runs counter to that important theory of patent law. Such a conclusion, whether by a jury, as here, or by a judge, makes a mockery of claims.

Moreover, shockingly, the patent owner in this case cross appeals on the issue of willful infringement and relies on supposed evidence that the accused infringer allegedly copied the patent owner’s product. To argue willfulness in making or selling a device that fails in four separate respects to literally meet the claims would almost qualify for a chutzpah award. *See Dainippon Screen Mfg. Co. v. CFMT, Inc.*, 142 F.3d 1266, 1271 (Fed. Cir. 1998); *Refac Int’l, Ltd. v. Lotus Dev. Corp.*, 81 F.3d 1576, 1584 (Fed. Cir. 1996); *Checkpoint Sys., Inc. v. United States Int’l Trade Comm’n*, 54 F.3d 756, 763 n.7 (Fed. Cir. 1995) (noting that “chutzpah” describes “the behavior of a person who kills his parents and pleads for the court’s mercy on the ground of being an orphan”). The only acts that seem willful were avoiding the patented device.

We have here found deficiencies in the district court’s analysis of element (h) of the asserted claim, but I write only to call attention to the danger in the orderly thinking about infringement determinations, by business people, by attorneys, or by courts, in extending equivalence to multiple claim limitations, which has the potential of destroying the primacy of claims. Yes, we have a doctrine of equivalents, but “it is the exception . . . not the rule, for if the public comes to believe (or fear) that the language of patent

claims can never be relied on, and that the doctrine of equivalents is simply the second prong of every infringement charge, regularly available to extend protection beyond the scope of the claims, then claims will cease to serve their intended purpose.” *Wallace London & Clemco Prods. v. Carson Pirie Scott & Co.*, 946 F.2d 1534, 1538 (Fed. Cir. 1991).

United States Court of Appeals for the Federal Circuit

OLAF SOOT DESIGN, LLC,
Plaintiff-Cross-Appellant

v.

DAKTRONICS, INC.,
Defendant-Appellant

2020-1009, 2020-1034

Appeals from the United States District Court for the Southern District of New York in No. 1:15-cv-05024-GBD-OTW, Judge George B. Daniels.

JUDGMENT

THIS CAUSE having been considered, it is

ORDERED AND ADJUDGED:

REVERSED-IN-PART AND DISMISSED-IN-PART

ENTERED BY ORDER OF THE COURT

January 7, 2021

/s/ Peter R. Marksteiner
Peter R. Marksteiner
Clerk of Court

CERTIFICATE OF SERVICE

I hereby certify that on February 22, 2021, I electronically filed the foregoing document with the Clerk of the Court using CM/ECF, thereby serving it on all counsel of record via the CM/ECF system.

/s/ James M. Bollinger

James M. Bollinger

TROUTMAN PEPPER HAMILTON

SANDERS LLP

875 Third Avenue

New York, New York 10022

(212) 704-6000

CERTIFICATE OF COMPLIANCE

I certify that this submission complies with the type-volume limitation of Fed. R. App. P. 35(b)(2)(A). This submission contains 3,515 words, excluding the portions exempted by Fed. R. App. P. 32(f) and Fed. Cir. R. 35(c)(2).

I certify this submission complies with the typeface requirements of Fed. R. App. P. 32(a)(5) and the type style requirements of Fed. R. App. P. 32(a)(6), because it has been composed in a proportionally-spaced typeface using Microsoft Word in 14-point Times New Roman font.

Dated: February 22, 2021

/s/ James M. Bollinger

James M. Bollinger
TROUTMAN PEPPER HAMILTON
SANDERS LLP
875 Third Avenue
New York, New York 10022
(212) 704-6000