

Nos. 2018-2103, -2228

---

**In the United States Court of Appeals  
for the Federal Circuit**

THE CHAMBERLAIN GROUP, INC.,  
PLAINTIFF-APPELLEE

v.

TECHTRONIC INDUSTRIES CO. LTD., TECHTRONIC INDUSTRIES  
NORTH AMERICA, INC., ONE WORLD TECHNOLOGIES, INC.,  
OWT INDUSTRIES, INC., RYOBI TECHNOLOGIES, INC.,  
DEFENDANTS-APPELLANTS

ET TECHNOLOGY (WUXI) CO. LTD.,  
DEFENDANT

*ON APPEAL FROM THE UNITED STATES DISTRICT COURT FOR THE  
NORTHERN DISTRICT OF ILLINOIS, NO. 1:16-CV-06097  
HON. HARRY D. LEINENWEBER, PRESIDING*

**CORRECTED PETITION FOR REHEARING OR REHEARING EN BANC  
OF THE CHAMBERLAIN GROUP, INC.**

BENJAMIN C. ELACQUA  
*Fish & Richardson, P.C.*  
*1221 McKinney Street, Ste. 2800*  
*Houston, TX 77010*  
*(713) 654-5300*

MARIA E. STITELER  
*Fish & Richardson, P.C.*  
*3200 RBC Plaza, 60 South Sixth Street*  
*Minneapolis, MN 55402*  
*(612) 335-5070*

KATHERINE VIDAL  
MICHAEL R. RUECKHEIM  
MATTHEW R. MCCULLOUGH  
*Winston & Strawn LLP*  
*275 Middlefield Road, Ste. 205*  
*Menlo Park, CA 94025*  
*(650) 858-6500*

ANDREW C. NICHOLS  
ZACHARY B. COHEN  
*Winston & Strawn LLP*  
*1700 K Street, N.W.*  
*Washington, DC 20006*  
*(202) 282-5000*

[ADDITIONAL COUNSEL LISTED ON INSIDE COVER]

---

EIMERIC REIG-PLESSIS  
*Winston & Strawn LLP*  
*101 California Street*  
*San Francisco, CA 94111*  
*(415) 591-1000*

*Counsel for Petitioner*

## CERTIFICATE OF INTEREST

Pursuant to Federal Circuit Rules 27(a)(7) and 47.4(a), counsel for The Chamberlain Group, Inc. certifies the following:

**1. The full name of every party or amicus represented by us is:**

*The Chamberlain Group, Inc.*

**2. The name of the real party in interest (if the party named in the caption is not the real party in interest) represented by us is:**

*The Chamberlain Group, Inc.*

**3. All parent corporations and any publicly held companies that own 10% or more of the stock of any party represented by us are:**

*The Duchossois Group, Inc.*

**4. The names of all law firms and the partners or associates that appeared for the parties now represented by us in the trial court or expected to appear in this court are:**

*Winston & Strawn LLP: Katherine Vidal; Aldo A. Badini; Zach Cohen; Thomas M. Melsheimer; Andrew C. Nichols, Michael R. Rueckheim; Matthew R. McCullough; Steffen N. Johnson\*; Shanna A. Lehrman; Eimeric Reig.*

*Fish & Richardson P.C.: Benjamin C. Elacqua; Maria Elena Stiteler; Christopher O. Green; Benjamin Thompson; Jacqueline Tio; and Karan Jhurani.*

*Fitch, Even, Tabin & Flannery LLP: Nicole R. Little.*

**5. The title and number of any case known to counsel to be pending in this or any other court or agency that will directly affect or be directly affected by this court's decision in the pending appeal:**

*None.*

\*No longer with Winston & Strawn.

Dated: October 23, 2019

/s/ Katherine Vidal  
Katherine Vidal

## TABLE OF CONTENTS

CIRCUIT RULE 35(b)(2) STATEMENT.....	1
INTRODUCTION .....	3
BACKGROUND .....	7
POINTS OF LAW OVERLOOKED BY THE PANEL .....	12
ARGUMENT .....	12
I.    By deciding eligibility under <i>Alice</i> step two in the first instance on appeal and failing to defer to factual findings by the district court and jury, the decision exceeds this Court’s appellate role. ....	12
II.   Rehearing is needed because the decision misapplies <i>Alice</i> step two.....	16
CONCLUSION.....	17

**TABLE OF AUTHORITIES**

	<b>Page(s)</b>
<b>Cases</b>	
<i>Aatrix Software, Inc. v. Green Shades Software, Inc.</i> , 882 F.3d 1121 (Fed. Cir. 2018) .....	1, 4, 5, 13
<i>Alice Corp. Pty. Ltd. v. CLS Bank Int’l</i> , 573 U.S. 208 (2014).....	<i>passim</i>
<i>Apple Inc. v. Samsung Elecs. Co.</i> , 839 F.3d 1034 (Fed. Cir. 2016) .....	1, 7, 14, 16
<i>Atl. Thermoplastics Co. v. Faytex Corp.</i> , 5 F.3d 1477 (Fed. Cir. 1993) .....	1, 4, 14
<i>Berkheimer v. HP Inc.</i> , 881 F.3d 1360 (Fed. Cir. 2018) .....	1, 13, 15
<i>Cellspin Soft, Inc. v. Fitbit, Inc.</i> , 927 F.3d 1306 (Fed. Cir. 2019) .....	15
<i>Eli Lilly &amp; Co. v. Hospira, Inc.</i> , 933 F.3d 1320 (Fed. Cir. 2019) .....	14
<i>Exergen Corp. v. Kaz USA, Inc.</i> , 725 F. App’x 959 (Fed. Cir. 2018) .....	14
<i>Int’l Rectifier Corp. v. Samsung Elecs. Co.</i> , 424 F.3d 1235 (Fed. Cir. 2005) .....	13
<i>Internet Patents Corp. v. Active Network, Inc.</i> , 790 F.3d 1343 (Fed. Cir. 2015) .....	15
<i>Mayo Collab. Servs. v. Prometheus Labs., Inc.</i> , 566 U.S. 66 (2012).....	15, 17
<i>MyMail, Ltd. v. ooVoo, LLC</i> , 934 F.3d 1373 (Fed. Cir. 2019) .....	<i>passim</i>
<i>Nazomi Commc’ns, Inc. v. Arm Holdings, PLC</i> , 403 F.3d 1364 (Fed. Cir. 2005) .....	16

*Singleton v. Wulff*,  
428 U.S. 106 (1976).....15

*Takeda Pharm. Co. v. Zydus Pharms. USA, Inc.*,  
743 F.3d 1359 (Fed. Cir. 2014) .....14

*The Chamberlain Group v. Int’l Trade Comm’n*,  
No. 18-2002 (Fed. Cir.) .....4, 5

**Statutes**

35 U.S.C. § 101 .....1, 13

## CIRCUIT RULE 35(B)(2) STATEMENT

Based on my professional judgment, I believe the panel decision is contrary to the following decisions of the Supreme Court and this Court:

*Alice Corp. Pty. Ltd. v. CLS Bank Int'l*, 573 U.S. 208 (2014); *Aatrix Software, Inc. v. Green Shades Software, Inc.*, 882 F.3d 1121 (Fed. Cir. 2018); *Apple Inc. v. Samsung Elecs. Co.*, 839 F.3d 1034 (Fed. Cir. 2016); *Atl. Thermoplastics Co. v. Faytex Corp.*, 5 F.3d 1477, 1479 (Fed. Cir. 1993); *Berkheimer v. HP Inc.*, 881 F.3d 1360 (Fed. Cir. 2018); *MyMail, Ltd. v. ooVoo, LLC*, 934 F.3d 1373 (Fed. Cir. 2019).

Based on my professional judgment, I believe this appeal requires answers to precedent-setting questions of exceptional importance.

Patents are presumed valid under 35 U.S.C. § 101 unless a challenger proves by clear and convincing evidence that the claims: (1) are “directed to” an abstract idea; and (2) lack an “inventive concept,” i.e., “additional features” to ensure “that the [claim] is more than a drafting effort designed to monopolize the [abstract idea].” *Alice*, 573 U.S. at 217-18, 222 (quotations omitted). The second step of the *Alice* test is satisfied if the additional features – the claim elements or combinations of elements – are not “well-understood, routine, conventional.” *Id.* at 225. “The question of whether a claim element or combination of elements is well-understood, routine and conventional to a skilled artisan in the relevant field is a question of fact.” *Berkheimer*, 881 F.3d at 1368. The questions are:

1. Where the district court did not reach *Alice* step two, or address how the jury’s verdict of novelty and non-obviousness affects the factual aspects of step two, may this Court resolve step two in the first instance, treating step two as a purely legal issue in violation of *Berkheimer/Aatrix* and disregarding the jury verdict and related district court fact-finding, or must it remand?
2. Under *Alice* step two, is it improper for this Court to conflate *Alice* steps one and two, disregarding the concrete and structural combination of elements cited by the patent owner (i.e., the “additional features”) –

which here were the basis for the jury verdict of novelty and non-obviousness and the district court's related findings – and focus its step-two inquiry on the abstract idea itself, concluding as a tautology that there can be no inventive concept because the inventive concept cannot lie in the abstract idea?

Dated: OCTOBER 23, 2019

/s/ Katherine Vidal  
KATHERINE VIDAL  
*Counsel of Record*



## INTRODUCTION

Appellee The Chamberlain Group Inc. (“CGI”) seeks rehearing of a decision that: (1) resolves *Alice* step two in the first instance on appeal, treating it as a purely legal issue, in contravention of *Berkheimer/Aatrix*; and (2) when analyzing “inventive concept” under *Alice* step two, fails to analyze the “additional features” beyond the abstract idea.

After an eight-day jury trial and rulings on JMOL, the district judge rejected Appellant “TTI’s allegation that the asserted claims are directed to [an] abstract idea.” Op. 4. Reaching its conclusion of patent eligibility at *Alice* step one, “the [district] court did not reach step two.” *Id.*

On appeal, after determining that the claims of CGI’s ’275 Moveable Barrier Operator (“MBO”) patent (U.S. Patent No. 7,224,275) were directed to the “abstract idea of wirelessly communicating status information about a system,” the panel concluded under step two that the claims lacked an inventive concept. Op. 8, 10.

Not only did the panel err in resolving step two in the first instance, it misapplied an essential requirement of step two. Instead of setting aside the idea it found abstract and determining if what remains (the “additional elements”) contains an “inventive concept,” the panel disregarded all “additional elements.” The panel disregarded not only the specific hardware (the on-board transmitter) that implemented the abstract idea, but also additional elements (e.g., the *on-board controller*) (i) that

CGI pointed to as part of the inventive concept (Op. 10); and (ii) whose particular structural implementation plainly was part of the basis for the jury verdict of novelty and non-obviousness. The panel took the position that the only real alleged inventive concept was wireless communication – a finding that is contrary to the record, which makes clear that wireless communication was in the prior art, including in the Menard reference on appeal. *See infra* at 8-9. The court concluded that “[w]ireless communication cannot be an inventive concept here, because it is the abstract idea that the claims are directed to.” Op. 10.

*First*, the decision contravenes *Berkheimer/Aatrix* by deciding eligibility under *Alice* step two in the first instance. Step two turns on “[w]hether the claim elements or the claimed combination are well-understood, routine, conventional” – “a question of fact.” *Aatrix*, 882 F.3d at 1128. This Court has consistently recognized that “[f]act-finding by the appellate court is simply not permitted.” *Atl. Thermoplastics*, 5 F.3d at 1479. Indeed, five days before the decision here, another panel held that it could *not* reach step two precisely because it “may involve subsidiary fact questions,” and “[i]t is improper ... to determine factual issues in the first instance on appeal.” *MyMail*, 934 F.3d at 1380. This question also arose as recently as this month in the *Chamberlain v. TTI* ITC appeal (No. 18-2002 (Fed. Cir.)), where both TTI and the ITC took the position that if this Court were to reach the § 101 decision – which had been decided by the ALJ and vacated by the Commission – this Court

would be required to remand. *See id.*, Br. for Intervenors at 46-47; Br. for Appellee at 47. This error is particularly problematic here, where the district court did not reach the question of how the jury’s verdict of novelty and non-obviousness affects the factual aspects of step two of *Alice*.

*Second*, the decision conflates *Alice* steps one and two, focusing the step two inquiry on the abstract idea itself, disregarding the “additional elements” inquiry of *Alice*. Though this Court may determine that a certain structure does not impart inventive concept, for example if the structure is the equivalent of “stat[ing] the [abstract idea] while adding the words ‘apply it,’” *Alice*, 573 U.S. at 221 (quotations omitted), this Court may not go further. Here, at most, the recited “transmitter” performs the wireless communication. That is only one component of the claimed “operator” – a larger, novel machine including a novel *on-board controller* and other features that the district court found enables the moveable barrier operator to “experience” “status conditions,” thus “eliminat[ing] the need for a ‘physical interface ... to support numerous potentially utilized peripheral devices,’ thus cutting out ‘undesired additional cost when part of the [otherwise, necessarily installed] interface goes unused in a given installation,’” and bringing “new compatibility to the MBO.” CGI Op. Brief at 25 (citing Appx104-105).

Under *Alice* step two, when assessing a claim for “inventive concept,” precedent dictates that courts set aside the abstract idea, but no more than the abstract idea.

In other words, the court must determine if “[a] claim that recites an abstract idea ... include[s] ‘additional features’ to ensure ‘that the [claim] is more than a drafting effort designed to monopolize the [abstract idea].” *Alice*, 573 U.S. at 221 (citation omitted). Here, though doing so under step one, the district court found “additional features,” such as the *on-board controller* and its additional functionality and capabilities, that took the claims out of the case law directed to abstract ideas and merely “applying” and thus preempting that abstract idea. CGI explained this in its opening brief:

As the court explained, “the particularity of the claims – specifically, that the *controller* must experience the status conditions – diminishes [preemption] concerns.” Appx106. Indeed, both sides testified in the trial [sic] court that there are non-infringing alternatives for transmitting operator status information. Appx492, 376:9-11; Appx731-732, 1128:23-1129:8; *see also Elec. Power*, 830 F.3d at 1356 (observing that reciting a particular solution instead of a broad abstract idea “incentivizes further innovation in the form of alternative methods for achieving the same result”).

CGI Op. Br. at 27 (emphasis added).

Although the panel noted that in addressing inventive concept, CGI pointed to the presence of the *on-board controller* as part of a “specific implementation” of a “specific type of operator,” the panel asserts (without more) that “wireless transmission is the only aspect of the claims that CGI points to as allegedly inventive over the prior art.” Op. 10. The record does not support that position. Instead the very passage the panel cites supports the conclusion that CGI directed this Court to the

operator having the *on-board controller* which was independently inventive and valuable. The panel’s application of step 2 runs afoul of *Alice* and *Mayo* and sets a threshold for patentability never envisioned by the Supreme Court or this Court.

“[E]n banc” review is needed to affirm *Berkheimer/Aatrix* and “to affirm [this Court’s] understanding of the appellate function as limited to deciding the issues ... only on the basis of the record made below, and as requiring appropriate deference be applied to the review of fact findings.” *Apple*, 839 F.3d at 1039. This Court should grant en banc review to determine if it should vacate its step-two finding, both because the panel overstepped the proper role of an appellate court and because in doing so, it changed the subject of the inventive concept test under *Alice* step 2.

## BACKGROUND

The ’275 patent claims “[a] movable barrier operator” (for example, a garage-door opener) [10 (*in green*)] which includes onboard specific machinery (“a controller” and “transmitter”) [11 (*purple box*), 15 (*both in blue*)] never before integrated into a garage door opener to experience and, separately, transmit “status conditions.” Op. 3-4.

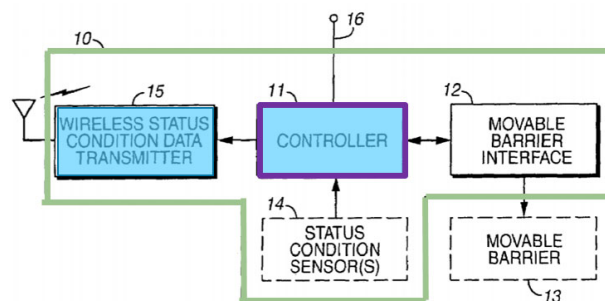
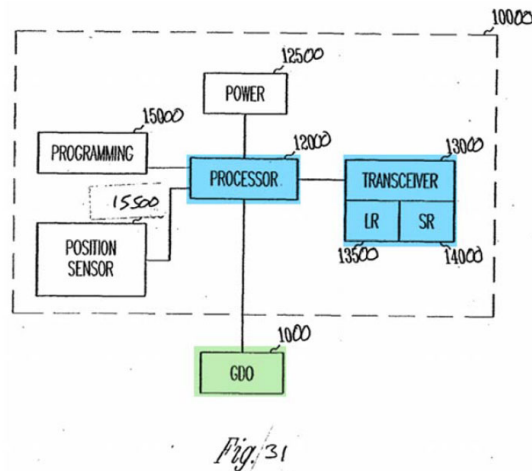

FIG. 1

Appx214 (highlighting added). Though the alleged abstract idea of transmitting status information wirelessly was admittedly known, the prior art like the Menard reference over which the jury found the '275 claims novel and nonobvious, did not have a smart MBO with an *on-board controller* or the other on-board devices that enable the MBO to be the hub of a smart home, but instead used *modular units* (such as 10000 below) connected to the moveable barrier operators (GDO 1000 below):



CGI Op. Br. at 33 (citing Appx12292 (highlighting added)). As explained in CGI's opening brief:

Menard, in contrast [to the '275 claims], describes a controller and wireless transmitter that are part of a *modular device* (system 10,000 in Figure 31) that are *separate and apart* from a garage door opener (GDO 1,000 in Figure 31). As such, Menard is simply like the modular prior art discussed in the '275's file history: devices that wirelessly transmit information wholly separate and apart from a garage door opener.

*Id.* at 34 (emphasis added).

After an eight-day jury trial, the jury found the '275 claims novel and nonobvious in view of Menard. Appx86.<sup>1</sup>

The district court likewise concluded that the claims are patent-eligible, finding numerous specific structural improvements reflected in the asserted claims, including ones unrelated to wirelessly transmitting:

[The '275] patent claims **recite such particular and unconventional improvements**. The moveable barrier operator ... taught by the '275 patent does not merely receive transmissions, as did MBOs in the prior art; instead, [CGI's] **MBO experiences – via an onboard controller – status conditions** and then transmits them to other devices. This improvement eliminated the need for a 'physical interface ... to support numerous potentially utilized peripheral devices,' thus cutting out 'undesired additional cost when part of the [otherwise, necessarily installed] interface goes unused in a given installation.'

CGI Op. Brief at 25 (citing Appx104-105). The district court recognized that by moving functionality into the MBO and creating a "smart" MBO, the '275 invention paved the way for connected homes:

In addition, the improvements taught by the '275 patent brought new compatibility to the MBO; the prior art, by contrast, "fail[ed] to permit compatible support of a given peripheral," and precluded users from coupling their prior-art MBO with a new function "not specifically supported by a given [MBO]."

Appx105.

---

<sup>1</sup> The '275 claims have repeatedly been upheld as novel and non-obvious. The PTO considered the '275 claims three times – first on allowance, and again when "den[ying] [TTI's] two petitions to institute *inter partes* review." Appx8.

The court rejected TTI's argument that the claims "are directed to patent-ineligible subject matter," finding them instead "directed to ... garage door openers." Op. 4. "Because it concluded that the asserted claims were not directed to any abstract idea, the court did not reach step two of *Alice*." *Id.*

Although it never reached step two, the district court found at step one that the claims recite "unconventional improvements." Appx104. The claimed machine, it found, "does not merely receive transmissions, as did ... the prior art," but incorporates "an *onboard controller*" that, among other things enabled the moveable barrier operator to experience "status conditions" – an "improvement [that] eliminated the need for a physical interface," "cut[] out undesired additional cost," and "brought new compatibility." Appx105 (emphasis added) (quotations omitted). The claims thus provide "enhanced flexibility, which transcends prior art conventions." Appx106.

The court found inventive elements that distinguished the prior art – including "that the controller must experience the status conditions" and that "the controller and transmitter ... are part of the [garage-door opener]" itself instead of "a separate module." Appx106, Appx110. The latter, in particular, was a "key limitation." Appx110. In other words, the district court found, as had the jury, that the claims recite particular, novel, and non-obvious elements in addition to what the panel later identified as the abstract idea.



The panel reversed.

The panel held that the claims are “directed to wirelessly communicating status information about a system,” which it deemed an “abstract idea.” Op. 5, 8. Although it conceded that the trial court “did not reach step two,” the panel “proceed[ed] to step two” itself. Op. 4, 8. Ignoring the district court’s step-one findings that the claims recite “unconventional improvements,” including the important role of the *on-board controller*, and ignoring the jury’s verdict that the claims were “novel” and “nonobvious[]” over prior art that disclosed the alleged abstract idea, Appx104-106, Appx113, the panel performed the step two analysis in the first instance, finding that the claims recite “no inventive concept” or “technological improvement.” Op. 7-10.

In so finding, the panel acknowledged that CGI relies on the “specific type of [garage door] operator” as providing inventive concept, and that the “specific type of operator” has not only a “wireless transmitter to transmit status information” but also an “integrated controller.” *Id.* at 10. The panel articulated the test as “beyond the idea of wirelessly communicating status information about a moveable barrier operator, what elements in the claim may be regarded as the ‘inventive concept,’” *id.*, and then proceeded to conflate the additional, novel, and non-obvious structural elements (e.g., the onboard controller) with the alleged abstract idea of wireless transmission, leaving nothing to analyze under *Alice* step two:

Yet wireless transmission is the only aspect of the claims that CGI points to as allegedly inventive over the prior art. *See, e.g.*, Appellee’s Op. Br. at 31 (“*[T]he ’275’s claims, like Bascom’s, are patent eligible because they ‘carve out’ a specific implementation (a specific type of operator with an integrated controller and wireless transmitter to transmit status information) that provide [sic] greater flexibility than the prior art physical interfaces approach.*”). Wireless communications cannot be an inventive concept here, because it is the abstract idea that the claims are directed to.

Op. 10 (emphasis added).

### POINTS OF LAW OVERLOOKED BY THE PANEL

First, in deciding *Alice* step two instead of remanding, the panel treated step two as a purely legal issue in contravention of *Berkheimer/Aatrix* and overlooked that appellate courts cannot “determine factual issues in the first instance on appeal.” *MyMail*, 934 F.3d at 1380 (quotation omitted).

Second, the panel misapplied the test under *Alice* step 2 that the “additional features,” beyond the abstract idea, be analyzed to “to ensure ‘that the [claim] is more than a drafting effort designed to monopolize the [abstract idea].’” *Alice*, 573 U.S. at 221 (quoting *Mayo Collab. Servs. v. Prometheus Labs., Inc.*, 566 U.S. 66, 77 (2012)).

### ARGUMENT

**I. By deciding eligibility under *Alice* step two in the first instance on appeal and failing to defer to factual findings by the district court and jury, the decision exceeds this Court’s appellate role.**

At step two, whether claims recite “an inventive concept, alone or in combination with other elements,” is among the “factual disputes underlying the § 101

analysis.” *Aatrix*, 882 F.3d at 1126. Indeed, “the second step ... is satisfied when the claim limitations involve more than performance of well-understood, routine, [and] conventional activities previously known to the industry.” *Id.* at 1128 (quotations omitted). “Whether the claim elements or the claimed combination are well-understood, routine, conventional is a question of fact.” *Id.* (quotations omitted).

“Because [the district court] concluded that the asserted claims were not directed to any abstract idea, [it] did not reach step two,” Op. 4, and thus never decided whether the claims recite “well-understood, routine, and conventional activities.” *Berkheimer*, 881 F.3d at 1370. All the fact-finding the district court (and jury) did perform supports a contrary conclusion. *Infra* at 15. Instead of affording deference or remanding, the panel decision “proceed[ed] to step two” in the first instance. Op. 8. That is unprecedented.

Days earlier, another panel held that it could not decide step-two eligibility because “[i]t is improper ... to determine factual issues in the first instance on appeal.” *MyMail*, 934 F.3d at 1380. The Court correctly “remand[ed] for further proceedings” “to determine in the first instance patent eligibility.” *Id.* at 1380-81. Because “[f]act-finding by the appellate court is simply not permitted,” *Atl. Thermoplastics*, 5 F.3d at 1479, this Court has consistently “remand[ed] for the district court to make fact findings in the first instance.” *Int’l Rectifier Corp. v. Samsung Elecs. Co.*, 424 F.3d 1235, 1241 (Fed. Cir. 2005).

If the panel here had *remanded* and the district court upheld the claims, any later review would have been limited to whether the court “committed clear error by finding that [TTI’s] evidence was not clear and convincing proof of invalidity.” *Takeda Pharm. Co. v. Zydus Pharms. USA, Inc.*, 743 F.3d 1359, 1368 (Fed. Cir. 2014); *Eli Lilly & Co. v. Hospira, Inc.*, 933 F.3d 1320, 1328 (Fed. Cir. 2019); *Exergen Corp. v. Kaz USA, Inc.*, 725 F. App’x 959, 965 (Fed. Cir. 2018); *Apple*, 839 F.3d at 1039. By instead resolving step two in the first instance, the decision preempts clear-error deference.

It is no answer to say that eligibility can be resolved legally when facts are undisputed. That is not the case here. The very sentence the panel cites for its position that CGI only pointed to the wireless transmission as inventive shows CGI’s reliance on the on-board controller and other aspects of the claims. Op. 10. “[A]ccepting [such] allegations as true, [the Court] cannot say that the asserted claims are ineligible ... as a matter of law.” *Cellspin Soft, Inc. v. Fitbit, Inc.*, 927 F.3d 1306, 1320 (Fed. Cir. 2019).

Indeed, here the district court made findings contrary to the panel’s conclusion, albeit not expressly under *Alice* step 2. “The district court ... determined that the asserted claims are directed to ‘a particular improvement over prior art which uses a particular manner of sending and experiencing data.’” Op. 4. The district

court also found that the claims recite “unconventional improvements,” “transcend[ing] prior art conventions.” Appx104-106. Those findings are equally relevant to whether the claims recite merely “conventional activities previously known.” *Berkheimer*, 881 F.3d at 1367.

After the jury found the claims novel and inventive over prior art (which disclosed the alleged abstract idea of wireless transmission), the district court found the claimed combination “particular and unconventional.” Appx106-114. These findings were also relevant to step two, which turns on “considerations analogous to those of §§ 102 and 103.” *Internet Patents Corp. v. Active Network, Inc.*, 790 F.3d 1343, 1347 (Fed. Cir. 2015); *Mayo*, 566 U.S. at 90.

Yet relying primarily on its conclusion in step one that the claims are directed to an abstract idea, the decision declares that the claims embody no “technological improvement” and lack any “inventive concept.” Op. 7-10. The decision never considers – much less defers to – any of the contrary findings below by the jury and district court. En banc review is needed to ensure that “appropriate deference be applied to ... fact findings.” *Apple*, 839 F.3d at 1039.

Even if step two turned on a purely legal question, “[i]t is the general rule ... that a federal appellate court does not consider an issue not passed upon below,” including “legal arguments.” *Singleton v. Wulff*, 428 U.S. 106, 120 (1976). The “review of a district court’s [legal conclusion], albeit without deference, nonetheless

is not an independent analysis in the first instance.” *Nazomi Commc’ns, Inc. v. Arm Holdings, PLC*, 403 F.3d 1364, 1371 (Fed. Cir. 2005). Only “sufficient findings and reasoning ... permit meaningful appellate scrutiny” – a requirement that “applies with equal force to issues of law.” *Id.* (quotation omitted).

Nor can TTI say that CGI waived any request for remand. This Court is required to follow *Alice* and its own precedent regardless of statements made by the parties. Though that should end the analysis, CGI made no such statements here and instead argued for *affirmance*.

The Court should grant CGI’s en banc petition to affirm *Berkheimer/Aatrix* and “to affirm [its] understanding of the appellate function as limited to deciding the issues ... only on the basis of the record made below.” *Apple*, 839 F.3d at 1039.

## **II. Rehearing is needed because the decision misapplies *Alice* step two.**

In addressing step two of *Alice*, the panel should have set aside the “abstract idea” of “wirelessly communicating status information about a system” (and at most under Federal Circuit precedent the transmitter that performs that function) and should have considered whether what remains (including the novel *on-board controller*) may be regarded as the inventive concept. The panel did not do so. Even if this Court were to set aside both the transmitting idea (that it found abstract) and the physical transmitter, the invention is something more complex: “[a] movable barrier operator” comprising a “transmitter” *and* two other components (the “controller”

and “interface”) integrated into a larger machine. Op. 3-4. Because of this, the district court found that there were no preemption concerns. *See supra*.

CGI claimed an inventive “particular application[]” of wireless transmission embodied in “a novel and useful structure,” which *Mayo* confirms is “patentable.” 566 U.S. at 71, 87 (quotation omitted).

For this independent reason, this Court should grant en banc review.

### **CONCLUSION**

Panel or en banc rehearing should be granted.

Respectfully submitted,

BENJAMIN C. ELACQUA  
*Fish & Richardson, P.C.*  
*1221 McKinney Street, Ste. 2800*  
*Houston, TX 77010*  
*(713) 654-5300*

MARIA E. STITELER  
*Fish & Richardson, P.C.*  
*3200 RBC Plaza, 60 South Sixth Street*  
*Minneapolis, MN 55402*  
*(612) 335-5070*

/s/ Katherine Vidal  
KATHERINE VIDAL  
MICHAEL R. RUECKHEIM  
MATTHEW R. MCCULLOUGH  
*Winston & Strawn LLP*  
*275 Middlefield Road, Ste. 205*  
*Menlo Park, CA 94025*  
*(650) 858-6500*

ANDREW C. NICHOLS  
ZACHARY B. COHEN  
*Winston & Strawn LLP*  
*1700 K Street, N.W.*  
*Washington, DC 20006*  
*(202) 282-5000*

EIMERIC REIG-PLESSIS  
*Winston & Strawn LLP*  
*101 California Street*  
*San Francisco, CA 94111*  
*(415) 591-1000*

*Counsel for Petitioner*

OCTOBER 23, 2019



## CERTIFICATE OF COMPLIANCE

Petitioner The Chamberlain Group, Inc.'s petition is submitted in accordance with the type-volume limitations of Rule 35(b)(2)(A) of the Federal Rules of Appellate Procedure. This brief contains 3,742 words.

*/s/ Katherine Vidal* \_\_\_\_\_  
KATHERINE VIDAL

# **ADDENDUM**

**United States Court of Appeals  
for the Federal Circuit**

---

**THE CHAMBERLAIN GROUP, INC.,**  
*Plaintiff-Appellee*

v.

**TECHTRONIC INDUSTRIES CO., TECHTRONIC  
INDUSTRIES NORTH AMERICA, INC., ONE  
WORLD TECHNOLOGIES, INC., OWT  
INDUSTRIES, INC., RYOBI TECHNOLOGIES, INC.,**  
*Defendants-Appellants*

**ET TECHNOLOGY (WUXI) CO.,**  
*Defendant*

---

2018-2103, 2018-2228

---

Appeals from the United States District Court for the Northern District of Illinois in No. 1:16-cv-06097, Senior Judge Harry D. Leinenweber.

---

Decided: August 21, 2019

---

JUANITA ROSE BROOKS, Fish & Richardson, PC, San Diego, CA, argued for plaintiff-appellee. Also represented by MARIA ELENA STITELER, Minneapolis, MN; BENJAMIN ELACQUA, Houston, TX; STEFFEN NATHANAEL JOHNSON, Wilson Sonsini Goodrich & Rosati, Washington, DC; KATHERINE VIDAL, MATTHEW R. McCULLOUGH, MICHAEL

2 CHAMBERLAIN GROUP, INC. v. TECHTRONIC INDUSTRIES CO.  
LTD.

RUECKHEIM, Winston & Strawn LLP, Menlo Park, CA.

JASON C. WHITE, Morgan, Lewis & Bockius LLP, Chicago, IL, argued for defendants-appellants. Also represented by MICHAEL J. ABERNATHY, SANJAY K. MURTHY, NICHOLAS A. RESTAURI; JULIE S. GOLDEMBERG, Philadelphia, PA; WILLIAM R. PETERSON, Houston, TX; SEAN C. CUNNINGHAM, ERIN GIBSON, STANLEY JOSEPH PANIKOWSKI, III, DLA Piper LLP (US), San Diego, CA.

---

Before LOURIE, O'MALLEY, and CHEN, *Circuit Judges*.

CHEN, *Circuit Judge*.

Techtronic Industries Co. Ltd., Techtronic Industries North America, Inc., One World Technologies, Inc., OWT Industries, Inc., and Ryobi Technologies, Inc. (collectively, TTI) appeal from the opinion and order of the United States District Court for the Northern District of Illinois denying TTI's motion for judgment as a matter of law (JMOL) and granting Chamberlain Group, Inc.'s (CGI) motions for enhanced damages and attorney fees. TTI also appeals the jury's verdict with respect to infringement and validity. We have jurisdiction under 28 U.S.C. § 1295(a)(1).

Because we conclude that claims 1, 5, and 15 of CGI's U.S. Patent No. 7,224,275 ('275 patent) are directed to an abstract idea and therefore patent-ineligible, we reverse the district court's JMOL decision with respect to the '275 patent on 35 U.S.C. § 101 grounds. We affirm the jury's verdict with respect to its finding of no anticipation of claims 14, 17, and 18 of CGI's U.S. Patent No. 7,635,966 ('966 patent) by U.S. Patent No. 6,484,784 (Weik). Accordingly, we vacate the district court's injunction and its awards of enhanced damages and attorney fees, and remand to the district court for reconsideration of enhanced damages and attorney fees with respect to only the '966 patent.

CHAMBERLAIN GROUP, INC. v. TECHTRONIC INDUSTRIES CO. 3  
LTD.

#### A. THE '275 PATENT

The '275 patent relates to an apparatus and method for communicating information about the status of a movable barrier, for example, a garage door. The '275 patent explains that, “[o]ver time, the capabilities of and features supported by . . . movable barrier operators . . . expanded to include actions other than merely opening and closing a corresponding movable barrier.” '275 patent at col. 1, ll. 31–34. Some movable barrier operators could provide ambient lighting, for example, or sense the presence of an obstacle in the path of the movable barrier and take an appropriate action. *Id.* at col. 1, ll. 34–38. The '275 patent explains that the movable barrier operator may communicate information relating to the movable barrier’s status with respect to these actions with various peripheral devices, including sensors, alarms, displays, lights, and so forth. *Id.* at col. 1, ll. 54–61. Rather than communicating this information over a physical signaling path, the asserted claims recite communicating it wirelessly. *Id.* at col. 1, l. 64 – col. 2, l. 16. The specification describes wireless transmitters as being “well understood in the art.” *Id.* at col. 3, l. 54 – col. 4, l. 4.

The parties do not contest the district court’s treatment of claim 1 as representative. Claim 1 recites:

1. A movable barrier operator comprising:

a controller having a plurality of potential operational status conditions defined, at least in part, by a plurality of operating states;

a movable barrier interface that is operably coupled to the controller;

a wireless status condition data transmitter that is operably coupled to the controller, wherein the wireless status condition data transmitter transmits a status condition signal that:

4 CHAMBERLAIN GROUP, INC. v. TECHTRONIC INDUSTRIES CO.  
LTD.

corresponds to a present operational status condition defined, at least in part, by at least two operating states from the plurality of operating states; and

comprises an identifier that is at least relatively unique to the movable barrier operator, such that the status condition signal substantially uniquely identifies the movable barrier operator.

*Id.* at claim 1.

TTI moved for JMOL that the asserted claims of the '275 patent are directed to patent-ineligible subject matter under § 101. The district court denied TTI's motion, disagreeing with TTI's allegation that the asserted claims are directed to the abstract idea of wireless transmission of content. *See* J.A. 98. The district court determined that, "[h]ere, the '275 patent claims are not directed to the transmission of data, but to garage door openers that wirelessly transmit status information." J.A. 99 (internal quotation marks omitted). The district court further determined that the asserted claims are directed to "a particular improvement over prior art which uses a particular manner of sending and experiencing data," which it deemed patent-eligible in light of this court's decision in *Core Wireless Licensing S.A.R.L. v. LG Electronics, Inc.*, 880 F.3d 1356, 1361 (Fed. Cir. 2018), and various other decisions. J.A. 103–05. Because it concluded that the asserted claims were not directed to any abstract idea, the court did not reach step two of *Alice Corp. Pty. Ltd. v. CLS Bank Int'l*, 573 U.S. 208, 218 (2014). J.A. 106.

Patent eligibility under § 101 is a question of law that may contain underlying issues of fact. *Interval Licensing LLC v. AOL, Inc.*, 896 F.3d 1335, 1342 (Fed. Cir. 2018) (citing *Berkheimer v. HP Inc.*, 881 F.3d 1360, 1365 (Fed. Cir. 2018)). We review an ultimate conclusion on patent eligibility de novo. *See id.*

CHAMBERLAIN GROUP, INC. v. TECHTRONIC INDUSTRIES CO. 5  
LTD.

The Supreme Court has deemed certain categories of subject matter, including abstract ideas, ineligible for patent protection under § 101. *Mayo Collaborative Servs. v. Prometheus Labs., Inc.*, 566 U.S. 66, 70 (2012). “The ‘abstract ideas’ category embodies the longstanding rule that an idea of itself is not patentable.” *Alice Corp.*, 573 U.S. at 218 (internal brackets and quotation marks omitted). To determine whether claimed subject matter is patent-eligible, we apply the two-step framework set forth in *Alice*. *Id.* First, we “determine whether the claims at issue are directed to a patent-ineligible concept,” such as an abstract idea. *Id.* Second, if so, we “examine the elements of the claim to determine whether it contains an ‘inventive concept’ sufficient to ‘transform’ the claimed abstract idea into a patent-eligible application.” *Id.* at 221 (quoting *Mayo*, 566 U.S. at 72, 80).

#### 1. Step One

At step one, we “look at the focus of the claimed advance over the prior art to determine if the claim’s character as a whole is directed to excluded subject matter.” *Affinity Labs of Tex., LLC v. DIRECTV, LLC*, 838 F.3d 1253, 1257 (Fed. Cir. 2016) (internal quotation marks omitted). “[T]he specification [is] helpful in illuminating what a claim is ‘directed to.’” *ChargePoint, Inc. v. SemaConnect, Inc.*, 920 F.3d 759, 766 (Fed. Cir. 2019). “But while the specification may help illuminate the true focus of a claim, when analyzing patent eligibility, reliance on the specification must always yield to the claim language in identifying that focus.” *Id.*

We conclude that claim 1 is directed to wirelessly communicating status information about a system. *See, e.g.*, ’275 patent at claim 1 (reciting that “the wireless status condition data transmitter transmits a status condition signal that: corresponds to a present operational status condition defined, at least in part, by at least two operating states”). The specification supports this conclusion. The

6 CHAMBERLAIN GROUP, INC. v. TECHTRONIC INDUSTRIES CO.  
LTD.

only described difference between the prior art movable barrier operator systems and the claimed movable barrier operator system is that the status information about the system is communicated wirelessly, in order to overcome certain undesirable disadvantages of systems using physical signal paths—additional cost, exposed wiring, and increased installation time. *See id.* at col. 1, l. 49 – col. 2, l. 16, col. 3, ll. 16–26.

Wirelessly communicating status information about a system is similar to abstract ideas we have found in our previous cases. *See Amdocs (Israel) Ltd. v. Openet Telecom, Inc.*, 841 F.3d 1288, 1294 (Fed. Cir. 2016) (explaining that courts typically “examine earlier cases in which a similar or parallel descriptive nature can be seen” as part of their abstract idea analysis). In *DIRECTV*, we found claims reciting the function of wirelessly communicating regional broadcast content to an out-of-region recipient to be directed to the abstract idea of “providing out-of-region access to regional broadcast content.” *DIRECTV*, 838 F.3d at 1258. In *Affinity Labs of Texas, LLC v. Amazon.com Inc.*, 838 F.3d 1266 (Fed. Cir. 2016), we found claims reciting media systems that deliver streaming content to a handheld wireless electronic device to be directed to the abstract idea of “delivering user-selected media content to portable devices.” *Id.* at 1269. As such, the broad concept of communicating information wirelessly, without more, is an abstract idea.

This case is unlike those in which we have determined that the claims were not directed to abstract ideas. In *Thales Visionix Inc. v. United States*, 850 F.3d 1343, 1344–45 (Fed. Cir. 2017), to which CGI likens the asserted claims, the claimed advance over the prior art related to a new, specific way in which sensors measured inertial changes. *See id.* at 1345. In the prior art, the measurement occurred with respect to the earth, but, in the asserted claims, “[w]hen the moving platform accelerates or turns, the inertial sensor on the platform directly measures the



CHAMBERLAIN GROUP, INC. v. TECHTRONIC INDUSTRIES CO. 7  
LTD.

gravitational effect in the moving reference frame and the system therefore requires fewer measured inputs (and fewer points of potential error) to determine the position and orientation of the tracked object.” *Id.* at 1345. “By changing the reference frame, one [could] track the position and orientation of the object within the moving platform without input from a vehicle attitude reference system or calculating orientation or position of the moving platform itself.” *Id.* This created multiple advantages over prior art systems, including increased accuracy and independent operation. *Id.* The asserted claims here are not limited to a specific implementation of a technological improvement to communication systems. Rather, they simply recite a system that wirelessly communicates status information.

Nor do the asserted claims “focus on a specific means or method that improves the relevant technology,” *McRO, Inc. v. Bandai Namco Games Am. Inc.*, 837 F.3d 1299, 1314 (Fed. Cir. 2016), or “effect an improvement in any other technology or technical field,” *DDR Holdings, LLC v. Hotels.com, L.P.*, 773 F.3d 1245, 1265 (Fed. Cir. 2014) (quoting *Alice*, 573 U.S. at 225). The specification admits that the act of transmitting data wirelessly is “well understood in the art,” and no other changes to the generically claimed movable barrier operator are recited in the asserted claims or described in the specification. ’275 patent at col. 3, ll. 54–60. Moreover, that the claimed invention transmits data wirelessly and therefore does not rely on a wired path is not itself a technological improvement, but rather simply a feature of wireless communication, which the specification explains was already a basic, conventional form of communication.

The district court likened this case to *Core Wireless*. In *Core Wireless*, we determined that claims drawn to improved interfaces for electronic devices with small screens that allowed users to more quickly access desired data stored in, and functions of applications included in, the electronic devices were not drawn to the abstract idea of an

8 CHAMBERLAIN GROUP, INC. v. TECHTRONIC INDUSTRIES CO.  
LTD.

index. *Core Wireless*, 880 F.3d at 1359, 1362. We concluded that the claims recited “a specific improvement over prior systems, resulting in an improved user interface for electronic devices.” *Id.* at 1363. The same is not true here, where the claims merely recite a system that communicates status information, in the same “well understood” manner that wireless transmissions have always occurred. *See* ’275 patent at col. 3, ll. 54–60. Unlike *Core Wireless*, no specific manner of performing the abstract idea is recited in these claims.

CGI alleges that its claims are not directed to an abstract idea, but instead to a novel combination of its prior art movable barrier operator with a transmitter that is wireless. The district court’s analysis mirrored CGI’s approach. *See* J.A. 99–105. But “[t]he Supreme Court and this court have repeatedly made clear that merely limiting the field of use of the abstract idea to a particular existing technological environment does not render the claims any less abstract.” *DIRECTV*, 838 F.3d at 1259.

Last, CGI’s reliance on the asserted claims being directed to “physical real world manifestation[s] of an improved machine” is misplaced. *See* Appellee’s Op. Br. at 22. Without more, the mere physical nature of CGI’s claim elements (*e.g.*, controller, interface, and wireless data transmitter) is not enough to save the claims from abstractness, where the claimed advance is directed to the wireless communication of status information using off-the-shelf technology for its intended purpose. *See In re Marco Guldenaar Holding B.V.*, 911 F.3d 1157, 1161 (Fed. Cir. 2018).

Because we find that the asserted claims are drawn to the abstract idea of wirelessly communicating status information about a system, we proceed to step two of the analysis.

CHAMBERLAIN GROUP, INC. v. TECHTRONIC INDUSTRIES CO. 9  
LTD.

## 2. Step Two

“The ‘inventive concept’ step requires us to look with more specificity at what the claim elements add, in order to determine whether they identify an ‘inventive concept’ in the application of the ineligible subject matter to which the claim is directed.” *DIRECTV*, 838 F.3d at 1258 (internal quotation marks omitted). “Simply appending conventional steps, specified at a high level of generality, [i]s not enough to supply an inventive concept.” *Alice*, 573 U.S. at 222 (internal quotation marks and emphasis omitted).

The specification describes each individual element of the asserted claims—including the controller, the interface, and the wireless data transmitter—as “well understood in the art.” ’275 patent at col. 3, l. 27 – col. 4, l. 4. These conventional components, all recited in a generic way, are no better equipped to save the claim from abstractness than were, for example, the conventional computer used in *Alice* or the scanner used in *Content Extraction & Transmission LLC v. Wells Fargo Bank, National Ass’n*, 776 F.3d 1343, 1347 (Fed. Cir. 2014).

CGI argues that the ordered combination of the asserted claims’ elements provides the inventive concept because “there is no evidence in the record” that “a new type of movable barrier operator that includes an integrated controller and a wireless transmitter to transmit a status signal” was “well-understood, routine and conventional to a skilled artisan.” Appellee’s Op. Br. at 28 (citing *Berkheimer*, 881 F.3d at 1368). CGI misunderstands our case law. The appropriate question is not whether the entire claim as a whole was “well-understood, routine [and] conventional” to a skilled artisan (*i.e.*, whether it lacks novelty), but rather, there are two distinct questions: (1) whether each of “the [elements] in the claimed [product] (apart from the natural laws themselves) involve well-understood, routine, conventional activity previously engaged in by researchers in the field,” *Mayo*, 566 U.S. at 73, and

10 CHAMBERLAIN GROUP, INC. v. TECHTRONIC INDUSTRIES CO.  
LTD.

(2) whether all of the steps “*as an ordered combination* add[] nothing to the laws of nature that is not already present when the steps are considered separately,” *id.* at 79 (emphasis added). In other words, beyond the idea of wirelessly communicating status information about a movable barrier operator, what elements in the claim may be regarded as the “inventive concept”? This analysis applies to both system and method claims. *Alice*, 573 U.S. at 226.

As we explained above, the specification makes clear that transmitting information wirelessly was conventional at the time the patent was filed and could be performed with off-the-shelf technology. ’275 patent at col. 3, l. 54 – col. 4, l. 4. Yet wireless transmission is the only aspect of the claims that CGI points to as allegedly inventive over the prior art. *See, e.g.*, Appellee’s Op. Br. at 31 (“[T]he ’275’s claims, like Bascom’s, are patent-eligible because they ‘carve out’ a specific implementation (a specific type of operator with an integrated controller and wireless transmitter to transmit status information) that provide [sic] greater flexibility than the prior art physical interfaces approach.”). Wireless communication cannot be an inventive concept here, because it is the abstract idea that the claims are directed to. *See Interval Licensing*, 896 F.3d at 1347. Because CGI does not point to any inventive concept present in the ordered combination of elements beyond the act of wireless communication, we find that no inventive concept exists in the asserted claims sufficient to transform the abstract idea of communicating status information about a system into a patent-eligible application of that idea.

We therefore reverse the district court’s opinion and order to the extent that it found the asserted claims of the ’275 patent eligible for patent protection under § 101.

#### B. ’966 PATENT

The ’966 patent relates to a rechargeable battery backup system for a barrier movement operator. In the

CHAMBERLAIN GROUP, INC. v. TECHTRONIC INDUSTRIES CO. 11  
LTD.

event of a power outage, many garage door openers that are powered via electrical outlet cannot open and close the garage door, so, consequently, the garage door must be opened and closed manually. '966 patent at col. 1, ll. 25–27. It is therefore useful for the barrier movement operator to have a rechargeable battery to be used as a backup, but it is also inefficient to use separate, distinct rechargeable batteries for multiple devices, for example, with cordless power tools. *Id.* at col. 1, ll. 31–50. Accordingly, the invention of the '966 patent includes the ability for the barrier movement operator to be powered by a main power source, and the operator also possesses a battery charging system that charges a rechargeable battery capable of being used with both the barrier movement operator and other electrically powered equipment that may be stored in a garage. *Id.* at claim 1.

The jury found, *inter alia*, that the asserted claims of the '966 patent were not anticipated by Weik. J.A. 90. TTI moved for JMOL that Weik anticipates the asserted claims, which the district court denied. J.A. 134. The district court explained, quoting CGI's expert, that Weik “teaches a motor-operated door and discloses two different embodiments, one of which has a portable battery and no charger and one of which has a nonportable battery but does have a charger.” J.A. 131 (internal quotation marks omitted). TTI argued that a particular combination of these two embodiments (a portable battery with a charger) anticipates the asserted claims of the '966 patent. *Id.* Citing *Microsoft Corp. v. Biscotti, Inc.*, 878 F.3d 1052, 1069 (Fed. Cir. 2017), the district court stated that “[t]hough combinations of adjacently disclosed embodiments may be considered under the obviousness analysis, the same is not true for anticipation” and concluded that any testimony by TTI's expert explaining an anticipation theory relying on the combination of the two embodiments was improper as a matter of law. J.A. 132–33.

12 CHAMBERLAIN GROUP, INC. v. TECHTRONIC INDUSTRIES CO.  
LTD.

To the extent the district court suggested a blanket rule that two embodiments disclosed in a reference can never be considered in combination to make a finding of anticipation, this was incorrect. In *Kennametal, Inc. v. Ingersoll Cutting Tool Co.*, 780 F.3d 1376 (Fed. Cir. 2015), we explained that “a reference can anticipate a claim even if it ‘d[oes] not expressly spell out’ all the limitations arranged or combined as in the claim, if a person of skill in the art, reading the reference, would ‘at once envisage’ the claimed arrangement or combination.” *Id.* at 1381. Thus, even when a reference discloses elements in different locations in the disclosure, the relevant question is whether the reference is sufficiently clear in disclosing the combinability of those elements such that a skilled artisan would “at once envisage” the claimed combination. However, because TTI does not allege that the jury ever received the district court’s recitation of the law from the JMOL, and because TTI does not appeal any jury instructions containing the court’s language, we find any error by the district court to be harmless under the circumstances.

“Anticipation is a factual question, and a jury verdict regarding anticipation is reviewed after trial for substantial evidence.” *Eaton Corp. v. Rockwell Int’l Corp.*, 323 F.3d 1332, 1343 (Fed. Cir. 2003). Because Weik’s disclosure as to the possible combinability of the embodiments in the way TTI urges is less than clear, we agree with the district court that TTI has not met its burden of showing that the jury’s no-anticipation verdict was not supported by substantial evidence. Accordingly, we affirm the verdict.

### C. TTI’S REQUESTS FOR A NEW TRIAL

TTI moved at the district court for a new trial based on two grounds: (1) because the district court allegedly erred in denying TTI’s motion to transfer venue after the Supreme Court’s *TC Heartland* decision, and (2) because the district court allegedly erred in admitting into the record the Patent Trial and Appeal Board’s (Board) non-

CHAMBERLAIN GROUP, INC. v. TECHTRONIC INDUSTRIES CO. 13  
LTD.

institution decision with respect to TTI's petition for *inter partes* review of the '966 patent as evidence. The district court denied TTI's motion. We decline to reverse on either ground.

“In reviewing a district court's disposition of . . . a new trial motion, this court applies the law of the regional circuit where the district court sits,” here, the Seventh Circuit. *Bettcher Indus., Inc. v. Bunzl USA, Inc.*, 661 F.3d 629, 638 (Fed. Cir. 2011). The Seventh Circuit “give[s] great deference to a district court's rulings on motions to transfer venue.” *In re Chi., Milwaukee, St. Paul & Pac. R.R.*, 974 F.2d 775, 789 (7th Cir. 1992). “Indeed, [the appellate] court can only reverse a district court's determinations in this regard if [it] find[s] a ‘clear abuse of discretion.’” *Id.* (quoting *Cote v. Wadel*, 796 F.2d 981, 985 (7th Cir. 1986)). The Seventh Circuit's “standard of review in determining whether the district court committed reversible error in either the admission or exclusion of evidence is abuse of discretion.” *Geitz v. Lindsey*, 893 F.2d 148, 150 (7th Cir. 1990).

We do not find that the district court abused its discretion on either ground. As we explained in *In re Micron Technology, Inc.*, 875 F.3d 1091 (Fed. Cir. 2017), “Congress has provided express statutory confirmation of judicial authority to consider the timeliness and adequacy of a venue objection: 28 U.S.C. § 1406(b) provides that [n]othing in this chapter shall impair the jurisdiction of a district court of any matter involving a party who does not interpose timely and sufficient objection to the venue.” *Id.* at 1101. “[D]istrict courts have authority to find forfeiture of a venue objection,” for example where “venue objections based on *TC Heartland* . . . were presented close to trial.” *Id.* at 1101–02. In *Micron*, we pointed to cases—including for a writ of mandamus previously filed to our court by TTI that stemmed from the same underlying proceeding as this appeal—where we had previously denied mandamus and found no clear abuse of discretion where the motion to

14 CHAMBERLAIN GROUP, INC. v. TECHTRONIC INDUSTRIES CO.  
LTD.

transfer venue was filed two to three months before trial. *Id.* at 1102 & n.4. TTI waited almost thirty days after *TC Heartland* and two months before trial to file a motion to transfer venue. The district court did not abuse its discretion in denying TTI's motion to transfer venue under the circumstances here.

Nor did the district court abuse its discretion in admitting the Board's non-institution decision. TTI requested and the district court gave a limiting instruction to the jury explaining that the legal standards applied by the Patent Office and the legal standards the jury must apply may differ, for example the application of different claim constructions. *See* J.A. 148–49. The Supreme Court has previously approved of limiting instructions that direct juries to consider differences between proceedings at the Patent Office and in front of the district court. *See, e.g., Microsoft Corp. v. I4I Ltd. P'ship*, 564 U.S. 91, 111 (2011) (“When warranted, the jury may be instructed to consider that it has heard evidence that the PTO had no opportunity to evaluate before granting the patent. When it is disputed whether the evidence presented to the jury differs from that evaluated by the PTO, the jury may be instructed to consider that question.”). But district courts should still exercise caution when admitting evidence of a denial of institution because it may be confusing to the jury and prejudicial. We have often affirmed district courts in similar situations where the district courts exclude evidence of a non-final determination from ongoing proceedings at the Patent Office. *See SSL Servs., LLC v. Citrix Sys., Inc.*, 769 F.3d 1073, 1093 (Fed. Cir. 2014); *Callaway Golf Co. v. Acushnet Co.*, 576 F.3d 1331, 1342–43 (Fed. Cir. 2009). Although ongoing proceedings may be prejudicial for different reasons, such as being non-final, the concerns of confusing the jury because the Patent Office uses different standards from the district courts remains the same. Accordingly, both ongoing proceedings and denials of institution provide limited probative value that is likely to be outweighed by



CHAMBERLAIN GROUP, INC. v. TECHTRONIC INDUSTRIES CO. 15  
LTD.

the prejudice to the opposing party, and limiting instructions to the jury do not necessarily cure the prejudice. However, under the circumstances of this case, TTI has not shown an abuse of discretion. We affirm the district court's denial of TTI's motion for a new trial.

#### D. ENHANCED DAMAGES AND ATTORNEY FEES

Much of the district court's analysis awarding TTI enhanced damages and attorney fees was focused on activities relating to the '275 patent. Because we conclude that the asserted claims of the '275 patent are invalid under § 101 but affirm the jury's verdict with respect to the '966 patent, we vacate the district court's enhanced damages and attorney fees award and remand for the court to reconsider whether the award is warranted with respect to only the '966 patent.

#### CONCLUSION

For the reasons stated above, we reverse the district court's judgment as a matter of law with respect to the asserted claims of the '275 patent. We affirm the jury's verdict on anticipation with respect to the asserted claims of the '966 patent and the district court's determinations on TTI's motion for a new trial. We vacate the district court's injunction and its awards of enhanced damages and attorney fees, and we remand for reconsideration of enhanced damages and attorney fees consistent with this opinion. We have considered the parties' remaining arguments and find them unpersuasive.

#### **REVERSED-IN-PART, AFFIRMED-IN-PART, AND VACATED-AND-REMANDED-IN-PART**

No costs.

### **CERTIFICATE OF SERVICE**

I certify that on October 23, 2019, I electronically filed the foregoing corrected petition using the Court's CM/ECF filing system. All counsel of record were electronically served by and through the Court's CM/ECF filing system per Federal Rule of Appellate Procedure 25 and Circuit Rule 25.

/s/ Katherine Vidal  
KATHERINE VIDAL