

UNITED STATES PATENT AND TRADEMARK OFFICE

BEFORE THE PATENT TRIAL AND APPEAL BOARD

ON SEMICONDUCTOR CORPORATION,
SEMICONDUCTOR COMPONENTS INDUSTRIES, LLC
(d/b/a ON SEMICONDUCTOR),

Petitioner,

v.

POWER INTEGRATIONS, INC.,
Patent Owner.

Case IPR2016-00809
Patent 6,212,079 B1¹

Before THOMAS L. GIANNETTI, DANIEL N. FISHMAN, and
KERRY BEGLEY, *Administrative Patent Judges*.

FISHMAN, *Administrative Patent Judge*.

FINAL WRITTEN DECISION
35 U.S.C. § 318(a) and 37 C.F.R. § 42.73

¹ All challenged claims were newly added and issued in Reexamination Certificate US 6,212,079 C1. Ex. 1002.

I. INTRODUCTION

Semiconductor Components Industries, LLC (d/b/a ON Semiconductor) (“Petitioner”) filed a Petition (Paper 1, “Pet.”) for *inter partes* review of claims 31, 32, 34, 38, 39, and 42 (hereinafter the “challenged claims”) of U.S. Patent No. 6,212,079 B1 (Ex. 1001, “the ’079 patent”)² pursuant to 35 U.S.C. §§ 311–319. Power Integrations, Inc. (“Patent Owner”) filed a Patent Owner Preliminary Response (Paper 6, “Prelim. Resp.”). On September 23, 2016, based on the record before us at that time, we instituted an *inter partes* review of the challenged claims (Paper 12, “Dec.”). We instituted that review of claims 31, 32, 34, 37, 39, and 42 under 35 U.S.C. § 103(a) as obvious over the combination of Oda³ and Nakamura⁴. Dec. 28.

Patent Owner filed a Patent Owner Response (Paper 26, “PO Resp.”) and Petitioner filed a Reply (Paper 34, “Pet. Reply”). Petitioner relies on the expert Declarations of Dr. Vijay Madiseti (Exs. 1003 and 1061) and Patent Owner relies on the expert Declaration of Mr. David Bohannon (Ex. 2031).

² All challenged claims were introduced during reexamination of the ’079 patent (*see* Reexamination Application Nos. 90/007,771 and 90/008,376) and were issued in Ex Parte Reexamination Certificate US 6,212,079 C1. Ex. 1002. Thus, all references to the challenged claims of the ’079 patent refer to the claims as issued in US 6,212,079 C1.

³ Japanese Unexamined Patent Application Publication JP H10-323028. Ex. 1029. Exhibit 1029 is a certified English translation of the original Japanese document, Exhibit 1027.

⁴ Japanese Unexamined Patent Application Publication JP S59-144366. Ex. 1050. Exhibit 1050 is a certified English translation of the original Japanese document, Exhibit 1048.

Petitioner filed a Motion to Exclude Evidence (Paper 47), to which Patent Owner filed an Opposition (Paper 55) and Petitioner filed a Reply (Paper 60).

Patent Owner filed a Motion to Exclude Evidence (Paper 49), to which Petitioner filed an Opposition (Paper 56) and Patent Owner filed a Reply (Paper 59).

An Oral Hearing was conducted on June 30, 2017. The record contains a transcript of the hearing (Paper 66, “Tr.”).

We have jurisdiction under 35 U.S.C. § 6. The evidentiary standard is preponderance of the evidence. *See* 35 U.S.C. § 316(e); *see also* 37 C.F.R. § 42.1(d). This Final Written Decision is issued pursuant to 35 U.S.C. § 318(a) and 37 C.F.R. § 42.73.

For the reasons expressed below, we conclude that Petitioner has met its burden to show, by a preponderance of the evidence, that claims 31, 32, 34, 38, 39, and 42 are unpatentable.

A. The '079 Patent

According to the '079 patent, electronic devices use power supplies to provide operating power and a switched mode power supply is a type of supply that is commonly used “due to [its] high efficiency and good output regulation.” Ex. 1001, 1:11–13. In such switched mode supplies, a high voltage source (low frequency alternating current (“AC”) or direct current (“DC”)) is converted to a high frequency signal applied to the primary side of a transformer, the output of which generates a regulated DC voltage to be applied to a load coupled to the power supply. *See id.* at 1:15–25. The transformer output is regulated by control circuits sensing the transformer

output to generate a feedback signal to control the output of the transformer in a closed loop fashion. *See id.* at 1:25–38.

Control circuits in some prior designs modulate the width of the current pulses applied to charge a capacitor — i.e., increase the duty cycle (“on-time”) of applied pulses in response to detecting a heavy load on the power supply (e.g., at power up of a computer system). *Id.* at 1:38–45. Conversely, as the load on the power supply lightens, the duty cycle of the periodic pulses is reduced (i.e., the on-time for each periodic pulse is reduced). *Id.* at 1:45–48. According to the ’079 patent, as the load continues to lighten, the pulse width cannot be reduced indefinitely because poor power regulation may result. *Id.* at 1:49–53.

The ’079 patent further explains that to avoid such poor regulation, some prior switching regulators incorporate a constant internal load to maintain a constant minimum load level, thereby avoiding excessive reduction of pulse width. *Id.* at 1:53–54. This approach is disadvantageous, however, because such added load can reduce efficiency of the power supply (e.g., by wasting energy). *Id.* at 1:55–64.

The ’079 patent also explains that, to further reduce charging of the capacitor while avoiding such poor regulation and avoiding poor efficiency associated with an internal load, some prior switched power supplies skip pulsed cycles charging the capacitor. *Id.* at 1:65–2:11. However, according to the ’079 patent, such cycle skipping may result in audible noise being generated when the periodic pulse frequency, excluding skipped cycles, reaches the audible range. *Id.* at 2:11–16.

The ’079 patent purports to resolve these problems by providing a switched power supply control circuit “coupled to switch the power switch

at a fixed switching frequency for a first range of feedback signal values and coupled to vary a switching frequency of the power switch without skipping cycles in response to the feedback signal for a second range of feedback signal values.” *Id.* at 2:30–35. In other words, the ’079 patent’s control circuit operates the switched power supply in two modes — a fixed frequency mode and a variable frequency mode — and switches between the modes based on the range of the value of the feedback signal. *See id.* Figures 5 and 6 of the ’079 patent, reproduced below with our added annotations, illustrate the operation of an exemplary power supply switching regulator.

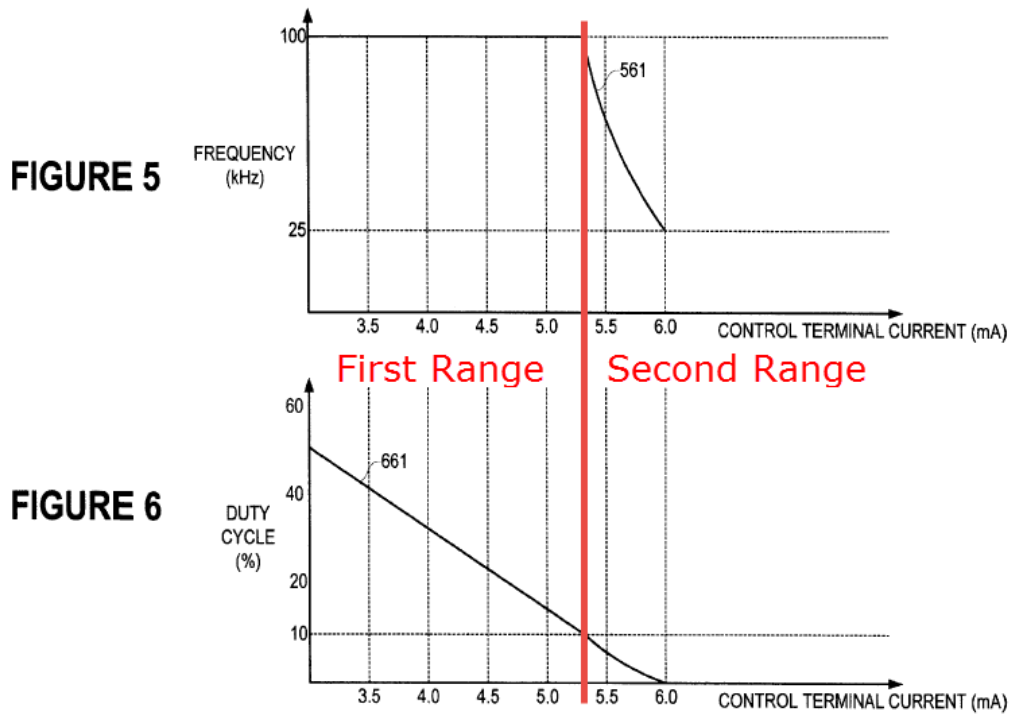

Figures 5 and 6 above are graphs illustrating the relationship of frequency versus feedback signal (current) and the relationship of pulse duty cycle versus the same feedback signal (current), respectively, as the pulse frequency and duty cycle are controlled in accordance with the ’079 patent.

See Ex. 1001, 9:30–53. The added red line annotation divides a first range of feedback signal values from a second range. In the first range, the switching frequency is fixed at 100 kHz (plot 561) while the duty cycle varies, decreasing from about 50% to about 10% (plot 661). *See id.* In the second range, both the frequency and the pulse duty cycle vary. *See id.* The frequency decreases from about 100 kHz down to about 25 kHz (561) while duty cycle continues to vary, decreasing from about 10% to about 0% (661). *See id.*

B. Real Parties in Interest

According to Petitioner, effective September 19, 2016, a planned merger between ON Semiconductor Corporation and Fairchild Semiconductor International, Inc. was completed such that the real parties in interest now consist of: ON Semiconductor Corporation; Semiconductor Components Industries, LLC (doing business as ON Semiconductor); Fairchild Semiconductor International, Inc.; Fairchild Semiconductor Corporation; Fairchild (Taiwan) Corporation, and System-General Corporation. Paper 16, 2–4.

C. Related Matters

Both parties identify as related matters IPR2016-00736 and two litigations related to the '079 patent in the U.S. District Court for the Northern District of California and both captioned *Power Integrations, Inc. v. Fairchild Semiconductor International, Inc.*, Case Nos. 09-cv-05235-MMC and 15-cv-04854-MMC. Pet. 2; Paper 5, 2. Petitioner also identifies another litigation related to the '079 patent in the U.S. District Court for the

IPR2016-00809
Patent 6,212,079 B1

Northern District of California captioned *Power Integrations, Inc. v. System General Corp.*, Case No. 5:04-cv-02851, and two *ex parte* reexamination proceedings (90/007,771 and 90/008,376) that led to issuance of the challenged claims. Pet. 2.

Both parties also identify a litigation filed in the U.S. District Court for the District of Arizona captioned *ON Semiconductor Corporation v. Power Integrations, Inc.*, Case No. 2:16-cv-02720. Paper 9, 3–4; Paper 10, 2 (“the Arizona case”). Petitioner further identifies a litigation in the U.S. District Court for the Northern District of California captioned *Power Integrations, Inc. v. ON Semiconductor Corp.*, Case No. 5:16-cv-06371. Paper 25, 2. Petitioner additionally indicates the Arizona case was transferred to the U.S. District Court for the Northern District of California as Case No. 3:17-cv-03189. Paper 63, 3.

The parties further identify the following additional Petitions for *Inter Partes* Review Petitioner has filed, two challenging other claims of the ’079 patent and other petitions challenging related patents owned by Patent Owner: IPR2016-01588, IPR2016-01589, IPR2016-01590 (challenging other claims of the ’079 patent), IPR2016-01592 (challenging other claims of the ’079 patent), IPR2016-01594, IPR2016-01595, IPR2016-00995, IPR2016-01597, IPR2016-01598, IPR2016-01599, and IPR2016-01600. Paper 9, 3; Paper 10, 3–4. Patent Owner further identifies IPR2016-01833, filed by the same Petitioner against a different patent owned by a different patent owner suggesting it may relate to the time bar under 35 U.S.C. § 315(b). Paper 11, 2. Petitioner disputes the relevance of IPR2016-01833 to this review. Paper 16, 6.

D. Illustrative Claims

Independent claims 31 and 34, reproduced below, are exemplary of the challenged claims (with formatting changes to enhance readability):

31. A switching regulator, comprising:

a power switch coupled between first and second terminals, the first terminal to be coupled to an energy transfer element of a power supply and the second terminal to be coupled to a supply rail of the power supply; and

a control circuit coupled to a third terminal and the power switch, the third terminal to be coupled to an output of the power supply,

the control circuit coupled to generate a feedback signal responsive to the output of the power supply,

the control circuit coupled to switch the power switch in response to the feedback signal,

the control circuit coupled to switch the power switch at a fixed switching frequency for a first range of feedback signal values,

the control circuit coupled to vary a switching frequency of the power switch without skipping cycles in response to the feedback signal for a second range of feedback signal values,

wherein the control circuit comprises:

a feedback signal circuit coupled to the third terminal, the feedback signal circuit coupled to generate the feedback signal; and

a pulse width modulator circuit coupled to switch the power switch in response to the feedback signal,

wherein the first and second ranges of the feedback signal correspond to first and second ranges of on-time values of a drive signal generated by the pulse width modulator circuit to switch the power switch.

34. A switching regulator, comprising:

a power switch coupled between first and second terminals, the first terminal to be coupled to an energy transfer element of a power supply and the second terminal to be coupled to a supply rail of the power supply; and

a control circuit coupled to a third terminal and the power switch, the third terminal to be coupled to an output of the power supply,

the control circuit coupled to generate a feedback signal responsive to the output of the power supply,

the control circuit coupled to switch the power switch in response to the feedback signal,

the control circuit coupled to switch the power switch at a fixed switching frequency for a first range of feedback signal values,

the control circuit coupled to vary a switching frequency of the power switch without skipping cycles in response to the feedback signal for a second range of feedback signal values,

wherein the control circuit comprises:

a feedback signal circuit coupled to the third terminal, the feedback signal circuit coupled to generate the feedback signal; and

a pulse width modulator circuit coupled to switch the power switch in response to the feedback signal, and

wherein on-time and off-time values of a drive signal generated by the pulse width modulator circuit to switch the power switch vary simultaneously as a function of a level of a load coupled to the output of the power supply to vary the switching frequency of the power switch without skipping cycles for the second range of feedback signal values.

II. ANALYSIS

A. *Statutory Bar Under 35 U.S.C. § 315(b)*

Section 315(b) of Title 35 of the U.S. Code provides that “[a]n *inter partes* review may not be instituted if the petition requesting the proceeding is filed more than 1 year after the date on which the petitioner, real party in interest, or privy of the petitioner is served with a complaint alleging infringement of the patent.” Our rules implementing this statutory requirement provide that:

A person who is not the owner of a patent may file with the Office a petition to institute an *inter partes* review of the patent unless: . . . (b) The petition requesting the proceeding is filed more than one year after the date on which the petitioner, the petitioner’s real party-in-interest, or a privy of the petitioner is served with a complaint alleging infringement of the patent.

37 C.F.R. § 42.101.

Patent Owner argues institution of *inter partes* review of this Petition was barred because Fairchild Semiconductor International, Inc. (“Fairchild”), now a real party in interest having merged with ON Semiconductor, was served with a complaint more than one year prior to *institution* of this Petition. PO Resp. 58–66.

Petitioner replies that Patent Owner raises no new arguments or evidence not previously considered in our Decision on Institution and, thus, Patent Owner’s arguments that this Petition should be time barred under section 315(b) should be rejected for the same reasons as in our Decision on Institution. Pet. Reply 29–30.

In our Decision on Institution, we considered the evidence of record regarding the alleged time bar under § 315(b). Petitioner acknowledges the existence of an Agreement and Plan of Merger (“Merger Agreement”)

between Petitioner and Fairchild Semiconductor International, Inc. (“Fairchild”). Pet. 1. The Merger Agreement generally calls for Falcon Operations Sub, Inc. (“Acquisition Sub”), a wholly owned subsidiary of Petitioner, to acquire Fairchild. Ex. 2018, 5.⁵ The Merger Agreement recites a number of conditions precedent to completion of the merger including, *inter alia*, regulatory approvals. *See, e.g., id.* at 6, 84–85.

Petitioner argues that at the time of filing this Petition, the merger was not yet completed and it was, at that time, “uncertain when or whether the merger will close.” Pet. 1. The Petition does not specify precisely which conditions to complete the merger had not been met at the timing of filing. Petitioner further argues “Fairchild has had no role in the decision to file this Petition, the content of this Petition, or the preparation of this Petition [and] did not contribute in any manner to the funding for this Petition.” *Id.* at 1–2. Thus, Petitioner contends that, at the time of filing this Petition, “Fairchild is not a real party in interest or a privy of any petitioner.” *Id.* at 2.

Petitioner asserts the planned merger was completed on September 19, 2016 after receiving regulatory approval from the United States on August 25, 2016 and from China on September 16, 2016. Paper 16, 2–3. Therefore, Fairchild was effectively merged with ON Semiconductor on September 19, 2016 (or at earliest, September 16, 2016), thus, becoming a real party in interest in this review as of that date. *Id.*

Panels of the Board have interpreted 315(b) (and our associated rule 37 C.F.R. § 42.101(b)) to mean that “it is only privity relationships up until the time a petition is filed that matter.” *Synopsys, Inc. v. Mentor Graphics*

⁵ Patent Owner entered the Merger Agreement into the record as Exhibit 2018.

Corp., Case IPR2012-00042, slip op. at 12 (PTAB Feb. 19, 2014) (Paper 60); *see also* *ARRIS Group, Inc. v. TQ Delta LLC*, Case IPR2016-00430, slip op. at 6 (PTAB July 1, 2016) (Paper 9). Although not the exclusive factor for establishing privity, control of the requested review procedure is an important factor to establish privity in this context. Our *Office Patent Trial Practice Guide* explains that “[w]hether a party who is not a named participant in a given proceeding nonetheless constitutes a . . . ‘privity’ to that proceeding is a highly fact-dependent question.” 77 Fed. Reg. 48,756, 48,759 (Aug. 14, 2012). “There are multiple factors relevant to the question of whether a non-party may be recognized as a . . . ‘privity.’” *Id.* “A common consideration is whether the non-party exercised or could have exercised control over a party’s participation in a proceeding.” *Id.* However, it is recognized that there is no definitive test regarding the degree of participation required to establish such control and, hence, to establish a privity relationship. *Id.*

In *ARRIS*, the panel determined that patent owner’s evidence of an agreement of a future merger was insufficient to show any degree of control over the requested review procedure or even the opportunity to do so. IPR2016-00430, Paper 9, 7. Here, as in *ARRIS*, we are not persuaded that the Merger Agreement detailing a future merger, which was not yet completed at the time of filing this Petition, is sufficient to demonstrate the opportunity for control over *this* proceeding by Fairchild. Here, the merger

was not complete as of the filing of the Petition but was completed on September 19, 2016.⁶ Paper 16, 2–3.

Similarly, Patent Owner’s arguments regarding the Confidentiality Agreement (Ex. 2026) are insufficient to demonstrate that Fairchild exercised, or could have exercised, any control over *this* proceeding. PO Resp. 65. The mere exchange of unidentified confidential information and recitations of the Confidentiality Agreement that the parties could be joint defendants in the future, without more, do not provide sufficient evidence that Fairchild has exercised, or could have exercised, any control over *this* proceeding. Thus, the record lacks sufficient evidence to demonstrate even the opportunity to control this review and, thus, to establish privity between Petitioner and Fairchild.

Patent Owner asserts our Decision on Institution relied on an incorrect interpretation of § 315(b). PO Resp. 58–60. Specifically, Patent Owner argues nothing in the statute “implies when privity/RPI status must exist, and general rules of statutory construction indicate that the present includes the future.” *Id.* at 59. According to Patent Owner, “the decision point is [the date of] institution not [the date of] filing.” *Id.* at 59–60. Under Patent Owner’s interpretation, we should have denied institution of this Petition because Fairchild, barred under § 315(b), became a real party in interest on

⁶ An argument could be made that the merger was completed September 16, 2016 when all conditions for completion of the merger were satisfied and was merely publicly announced the next business day, September 19, 2016. The difference between completion of the merger on September 19th versus completion of the merger on September 16th is of no significance in this IPR, given that both dates are before we instituted *inter partes* review on September 23rd.

September 19, 2016 — a few days before our Decision on Institution entered on September 23, 2016.

We disagree with Patent Owner’s proposed interpretation of the statute. The statute clearly defines the relevant event in the bar date determination as the *filing of the petition* more than one year after service of a complaint. The evidence of record is insufficient to show that Fairchild was a privy of Petitioner or a real party in interest either at the time of service of a complaint or more than a year later at the time of filing of this Petition.

Patent Owner acknowledges that there is no decision of this Board in support of its argument. PO Resp. 60. Patent Owner argues prior decisions of the Board in accord with our Decision on Institution regarding § 315(b) time bar were all decided incorrectly in view of various Federal Court decisions based on equitable principles of claim preclusion and issue preclusion. *Id.* at 60–63. Patent Owner specifically asserts “prior panels have not considered the interaction of federal preclusion principles with the timing issue: as noted by the Federal Circuit in *Kloster Speedsteel*, preclusion can arise after a complaint is filed.” *Id.* at 63 (citing *Kloster Speedsteel AB v. Crucible Inc.*, 793 F.2d 1565, 1583 (Fed. Cir. 1986)). Patent Owner concludes, “This strongly supports that preclusion under 35 U.S.C. § 315(b) should not be limited to the filing date of the petition. Since barred party Fairchild is now an admitted RPI, and was so before institution, this action should be dismissed.” *Id.*

Kloster is inapposite because, at least, it does not directly address the clear Congressional intent expressed in section 315(b) — namely that the determination of the time bar is based on the relationship of the parties to an

action up to the date of filing of a petition. Instead, in *Kloster*, Kloster was seeking relief from the scope of an injunction resulting from a judgment of infringement entered against a company it acquired. 793 F.2d at 1583. ON Semiconductor, in filing this Petition, is not seeking relief from a Federal District Court injunction — the Board possesses no such jurisdiction. Instead, Petitioner seeks a decision from the Board regarding patentability of certain claims of the '079 patent based on a combination of references not previously considered in the earlier litigation involving Fairchild.

Furthermore, Patent Owner's argument that "Fairchild is now an admitted RPI, and *was so before institution*" does not persuade us that institution of this review was barred under § 315(b). PO Resp. 63 (emphasis added). Although we agree that Fairchild is a real party in interest as of September 19, 2016 (or possibly September 16, 2016), we do not agree with the significance that Patent Owner seeks to place on Fairchild's status "before institution" — because it rests on Patent Owner's proposed interpretation of the relevant time period for § 315(b), which we find to be unsupported and contrary to our interpretation of § 315(b) as well as that in other Board decisions.

Lastly, Patent Owner argues ON Semiconductor filed this Petition acting as a proxy for Fairchild. PO Resp. 63–66. This is a new theory that was not presented in the Preliminary Response or in support of a request for authorization to file a proposed motion that Patent Owner filed seeking broad discovery into the details of the proposed transaction between ON and Fairchild. *See, e.g.*, Prelim. Resp. 4–11; Ex. 2034; Paper 24. Patent Owner submits it was "handicapped" by our rejection of Patent Owner's request for authorization to file a motion for additional discovery on the issue of privity

between ON Semiconductor and Fairchild. *Id.* at 63–64 (citing Paper 24, 2–4 and Ex. 2034). Therefore, Patent Owner points to “public facts” as evidence of such a proxy relationship. *Id.* at 64. As the “public evidence,” Patent Owner argues:

Indeed, ON filed a total of 12 IPR petitions after its merger with Fairchild was announced and before the merger’s closing. *See* Paper 10 at 3-4. Every one of those petitions relates to a PI [(Power Integrations)] patent Fairchild was found to infringe, or was accused of infringing, but where Fairchild was barred from seeking IPR. None of the filings involved a patent being litigated with ON when the filings were made. Also, ON has filed other IPRs for Fairchild. *See* IPR2016-01833 (petition filed against In-Depth Test LLC as proxy for Fairchild that was barred from filing an IPR). ON is gaming the system, and that should not be allowed to happen.

Id.

Patent Owner’s Response is the first time Patent Owner has argued that there was a *proxy* relationship between ON and Fairchild at the time of filing this Petition. Patent Owner’s earlier request for additional discovery related to an alleged *privity* between ON and Fairchild and did not raise the issue of a *proxy* relationship. *See* Ex. 2034. Furthermore, that request was denied because, *inter alia*, Patent Owner failed to provide any evidence, other than mere speculation, that privity existed. Paper 24, 4. Here, in the Patent Owner’s Response, as in the earlier request for additional discovery, Patent Owner still provides nothing more than mere speculation that ON Semiconductor filed this Petition merely as a proxy for Fairchild — a party barred under 315(b). The “public facts” relied upon may suggest a proxy relationship to Patent Owner but our *Garmin* factors require more than such speculation to grant additional discovery. *See Garmin Int’l, Inc. v. Cuozzo*

Speed Techs. LLC, 2013 WL 11311697 at 3–4 (PTAB Mar. 5, 2013) (precedential).

The *Office Patent Trial Practice Guide* cites *Taylor v. Sturgell*, 553 U.S. 880 (2008), as informing real party-in-interest determinations. 77 Fed. Reg. at 48,759–60. *Taylor* lists six categories that may create an exception to the common law rule that normally forbids nonparty preclusion in litigation. 553 U.S. at 893–95. One such category applicable here holds, “a party bound by a judgment may not avoid its preclusive force by relitigating through a proxy.” *Id.* at 895. *Taylor* refers to a proxy as a “representative or agent of a party who is bound by the prior adjudication.” *Id.* at 905. Another panel of the Board has applied this holding of *Taylor* to determine a proxy to be a “nominal plaintiff” with “no substantial interest” in the IPR proceeding other than that of its proxy “client.” *RPX Corp. v. VirnetX, Inc.*, IPR2014-00171, slip op. at 9 (PTAB July 14, 2014) (Paper 57). In *RPX*, it was clear that RPX had no interest in that IPR proceeding other than that of its underlying proxy client (Apple). *See id.* at 4–11. Although the record here does not indicate Petitioner has been sued for infringement of the ’079 patent up to the date of filing this Petition, ON Semiconductor, with a multi-billion dollar merger pending at the time of filing this Petition, has a clear interest in this Petition. On this record, the “public evidence” relied upon by Patent Owner is insufficient to demonstrate a proxy relationship such that Fairchild should be found to be a real party in interest using ON as a mere proxy.

Accordingly, we determine that, based on the evidence of record in this proceeding, 35 U.S.C. § 315(b) does not bar this petition from institution of *inter partes* review.

B. Claim Construction

In an *inter partes* review, a claim in an unexpired patent shall be given its broadest reasonable construction in light of the specification of the patent in which it appears. 37 C.F.R. § 42.100(b); *see also Cuozzo Speed Techs., LLC v. Lee*, 136 S. Ct. 2131, 2142–46 (2016) (upholding the use of the broadest reasonable interpretation standard).

Under the broadest reasonable construction standard, claim terms are generally given their ordinary and customary meaning, as would be understood by one of ordinary skill in the art in the context of the entire disclosure. *In re Translogic Tech., Inc.*, 504 F.3d 1249, 1079 (Fed. Cir. 2007). “[A] claim construction analysis must begin and remain centered on the claim language itself.” *Innova/Pure Water, Inc. v. Safari Water Filtration Sys., Inc.*, 381 F.3d 1111, 1116 (Fed. Cir. 2004). “Though understanding the claim language may be aided by the explanations contained in the written description, it is important not to import into a claim limitations that are not a part of the claim.” *SuperGuide Corp. v. DirecTV Enters., Inc.*, 358 F.3d 870, 875 (Fed. Cir. 2004). Only terms that are in controversy need to be construed and only to the extent necessary to resolve the controversy. *See Wellman, Inc. v. Eastman Chem. Co.*, 642 F.3d 1355, 1361 (Fed. Cir. 2011); *Vivid Techs., Inc. v. Am. Sci. & Eng’g, Inc.*, 200 F.3d 795, 803 (Fed. Cir. 1999).

Other than the terms we discuss below, we determine that it is unnecessary to construe any other claim terms.

1. “*Energy Transfer Element*”

Prior to institution, the parties disputed whether “energy transfer element,” as recited in each challenged claim, includes both flyback topology circuits and buck topology circuits. *See* Pet. 24–26; Prelim. Resp. 23–30. Flyback topology devices use a transformer as an “energy transfer element” to generate a desired output, whereas buck topology devices use an inductor as an “energy transfer element” for the generated output. *See* Ex. 1003 ¶ 40.

According to Petitioner, switched power supplies are a class of power converters that includes “buck-type topologies (which use an inductor) and flyback-type topologies (which use a transformer).” Pet. 25 (citing Ex. 1003 ¶ 40; Ex. 1034, 9–10, 27–28). Petitioner argues the ’079 patent discloses a transformer in a “flyback” architecture converter merely as an exemplary energy transfer element but contends the claimed “energy transfer element” is not limited to such an exemplary embodiment. *Id.* at 24–25. In particular, Petitioner contends “energy transfer element,” as recited in each of the challenged claims, also encompasses an inductor, such as is used in a buck topology power converter. *Id.* at 25. Petitioner further contends “energy transfer element” is a term of art used prior to the filing of the ’079 patent as encompassing both flyback (transformer) and buck (inductor) architecture converters. Pet. 25–26 (citing Exs. 1003 and 1035–1039 in support of this contention).

In its Preliminary Response, Patent Owner argued all challenged claims “require that, during drive signal on-times, the current flow through the power switch be from the first terminal coupled to an energy transfer element to the second terminal coupled to a supply rail, and as such, all

challenged claims exclude switching regulators in the [b]uck topology shown in Oda.” Prelim. Resp. 23 (emphasis omitted). Thus, Patent Owner contended that “the ’079 patent claims at issue here are limited to switching regulators for use in certain power converter topologies including a [f]lyback topology described in the ’079 patent, and excludes switching regulators used in power converters having the [b]uck topology disclosed in Oda.” *Id.* at 24.

In its Response, Patent Owner refers to Oda’s “non-isolated Buck converter,” but does not maintain its argument that the challenged claims exclude the buck converter architecture employed in Oda. *See* PO Resp. 18–20.

In our Decision on Institution, we agreed with Petitioner that nothing in the claims or the specification of the ’079 patent limits the term “energy transfer element” to only transformers in a flyback architecture converter and, more specifically, nothing in the claims defines a particular direction of current flow through the terminals of the power switch. Dec. 15–16. Thus, we determined that, in accordance with the broadest reasonable interpretation, “energy transfer element” should not be construed so narrowly as to include *only* a transformer (flyback topology converter) and to exclude an inductor (buck topology converter). *Id.* at 16. Instead, we determined “energy transfer element” is at least as broad as to encompass either a transformer or an inductor as utilized in flyback and buck architecture power converters, respectively. *Id.*

After considering all evidence and assertions anew, we discern no persuasive reason to alter our preliminary interpretation and conclude, for the reasons given in our Decision on Institution and this Decision, that

“energy transfer element” is at least as broad as to encompass either a transformer or an inductor as utilized in flyback and buck architecture power converters, respectively. *See id.* at 14–16.

2. *Variable On-time with Variable Frequency*

All challenged claims (independent claims 31, 34, 38, and 42 and, thus, also claims 32 and 39 dependent therefrom) recite,

the control circuit coupled to switch the power switch at a fixed switching frequency for a first range of feedback signal values,

the control circuit coupled to vary a switching frequency of the power switch without skipping cycles in response to the feedback signal for a second range of feedback signal values.

Ex. 1002, 2:15–21, 2:52–58, 3:31–37, 3:65–4:4. Thus, in accordance with the plain meaning of these recitations, all challenged claims require that the control circuit switches the power switch at a fixed frequency for a first range of feedback values and switches the power switch at variable frequencies for a second range of feedback values.

Claims 31 and 38 also include the recitation, “wherein the first and second ranges of the feedback signal correspond to first and second ranges of on-time values of a drive signal generated by the pulse width modulator circuit to switch the power switch.” *Id.* at 2:28–32, 3:37–41.⁷ In accordance with the plain meaning of this recitation, focusing on the second range of feedback values, we interpret claims 31 and 38 as further requiring the on-time of generated pulses to vary when the control circuit varies the frequency for the second range of feedback values.

⁷ We discuss further our interpretation of “corresponds to” below.

Claim 34 further includes the recitation, “wherein on-time and off-time values of a drive signal generated by the pulse width modulator circuit to switch the power switch vary simultaneously as a function of a level of a load coupled to the output of the power supply to vary the switching frequency of the power switch.” *Id.* at 2:65–3:4.⁸ Claim 42 includes a similar recitation. *Id.* at 4:4–8. We interpret the claims according to the plain meaning of this recitation in claims 34 and 42, again focusing on the second range of feedback values, as also requiring the on-time (and off time) of generated pulses to be varied when the control circuit varies the frequency for the second range of feedback values.

The specification of the ’079 patent is consistent with this plain meaning. *See, e.g.*, Ex. 1001, Abstract, 6:27–7:17, 9:30–10:7.

In our Decision on Institution, we determined the broadest reasonable interpretation of the above-identified recitations, consistent with the specification of the ’079 patent, is at least as broad as the plain meaning discussed *supra*. Dec. 18. Specifically, all challenged claims require the on-time of generated pulses to be varied when the control circuit varies the frequency for the second range of feedback values.

Patent Owner agrees with this interpretation. PO Resp. 31. Petitioner does not expressly discuss the construction of the above-identified recitations, but Petitioner’s analysis impliedly agrees with Patent Owner’s interpretation that, when operating within the second range of feedback values, both frequency and on-time are varied by the control circuit. *See, e.g.*, Pet. 47–50.

⁸ We discuss further our interpretation of “function of” below.

After considering all evidence and assertions anew, we discern no persuasive reason to alter our preliminary interpretation and again conclude that all challenged claims require the on-time of generated pulses to be varied when the control circuit varies the frequency for the second range of feedback values.

3. “Corresponds to”

Independent claims 31 and 38 both include the recitation “wherein the first and second ranges of the feedback signal correspond to first and second ranges of on-time values of a drive signal generated by the pulse width modulator circuit to switch the power switch.”

Patent Owner argues that, because the first and second ranges of feedback values require different operation with respect to the pulse frequency (fixed in the first range and variable in the second), “the first and second ranges [of feedback signals] must be non-overlapping subsets of all possible feedback signal values.” PO Resp. 32. Patent Owner then contends,

Similarly, the first and second ranges of on-time values must be non-overlapping subsets of all possible on-time values. The ranges must be non-overlapping because if a given feedback signal value corresponded to both the first range and the second range of on-time values, then it would make no sense to recite “the first and second ranges of the feedback signal correspond to first and second ranges of on-time values.” Instead, the claims would recite “the first and second ranges of the feedback signal correspond to ranges of on-time values.” The language requires the first and second on-time value ranges be non-overlapping unique subsets. As such, **it cannot be possible for a given feedback signal value to result in an on-time value in the first range in some cases and in the second range in others.** Likewise, it cannot be possible for **a particular drive signal**

on-time value to exist when in the first range of feedback signal but also for that same on-time to happen when in the second range of feedback signal.

Id. at 32–33. Patent Owner argues this interpretation of “corresponds to” is consistent with Figures 5 and 6 of the ’079 patent Specification showing the change in frequency and the change in pulse duty cycle as a function of error voltage. *Id.* at 33 (citing Ex. 2031 ¶¶ 63–67).

Petitioner does not propose a specific interpretation of this phrase but argues Patent Owner points to Figures 5 and 6 of the ’079 patent Specification as supporting its proposed interpretation and, thus, improperly attempts to import limitations from exemplary embodiments of the Specification into the claims. Pet. Reply 16.

We agree with Petitioner that Patent Owner’s proposed interpretation of “corresponds to” is unduly narrow and improperly imports exemplary embodiments from the Specification into the claims. We agree with Patent Owner in part in that the first and second ranges *of feedback values* must be non-overlapping because, as noted by Patent Owner, the claims require that the first and second ranges of feedback values produce different operation of the switching regulator regarding frequency. The claimed regulator generates a fixed frequency in the first range of feedback values and generates a variable frequency operation in the second range of feedback values. Thus, for a given value of feedback, the regulator must be in one of these two modes of frequency generation — not both. However, we disagree with Patent Owner that the first and second ranges of on-time values, to which the first and second ranges of feedback values “correspond,” necessarily require the first and second ranges of on-time values be non-overlapping. Specifically, we disagree with Patent Owner’s

assertion that **“it cannot be possible for a given feedback signal value to result in an on-time value in the first range in some cases and in the second range in others.”** PO Resp. 32. Such a limitation is simply not supported by the '079 patent Specification nor is it inherent in the plain meaning of “corresponds to.” It is clearly possible that a first range of on-time values and a second range may overlap such that a given feedback value in the first range of feedback values could generate an on-time value for pulses and could generate the same on-time value for a different value of the feedback signal in the second range of feedback values.⁹ Such an overlap of ranges of feedback values could be desired to provide hysteresis in control of the on-time values.

Nothing in the claims or the Specification of the '079 patent precludes overlap of values in the first and second ranges of on-time values. Figures 5 and 6 of the '079 patent may show such non-overlapping ranges of on-time if we assume those graphs are intended to be precise mathematical representations. However, nothing in the Specification of the '079 patent discloses such precision in these drawings. Even assuming such precision was intended, we decline to import limitations of exemplary embodiments from the Specification into the claims. *SuperGuide*, 358 F.3d at 875.

Thus, although we discern no need to expressly construe the phrase “corresponds to” as used in the claims, we determine “corresponds to” as used in the claims is at least as broad as to encompass non-overlapping first

⁹ Patent Owner’s narrow interpretation demands a one-to-one relationship between the feedback values and the pulse on-time values, i.e., a reversible function in mathematical terms. The '079 patent Specification does not support such a narrow interpretation.

and second ranges of feedback values corresponding to first and second ranges of on-time values regardless of overlap of feedback values in the first and second ranges of feedback values.

4. “Function of”

Independent claims 34 and 42 recite “wherein on-time and off-time values of a drive signal generated by the control circuit to switch the power switch vary simultaneously as a function of the feedback signal in the second range of feedback signal values.” Patent Owner argues the plain meaning of “function of” requires that “each **on-time and off-time value has exactly one value for any given value of, in the case of claim 34, a load level, and in the case of claim 42, a feedback signal responsive to the power supply output.**” *Id.* at 34. Patent Owner cites dictionary definitions to support its assertion that “[a] function has the property that each input is related to exactly one output.” *Id.* (citing Exs. 2051, 2052, 2053). In other words, Patent Owner’s argument asserts that “function of” means a function of a *single input variable* and excludes functions of multiple input variables.

Petitioner argues that Patent Owner’s cited dictionary definitions are merely exemplary and cites an alternative dictionary definition in which a function may be “a mathematical expression containing *one or more* variables.” Pet. Reply 16–17 (citing Ex. 1064).

We find Patent Owner’s proposed interpretation of the phrase “function of” unduly narrow. The word “function” (let alone the phrase “function of”) appears only in the claims of the ’079 patent and is not used, let alone defined, in the Specification. As above regarding Patent Owner’s

reliance on Figures 5 and 6, we discern no basis in the '079 patent for applying mathematical rigor to understanding the phrase “function of” as used in the claims. Even applying such mathematical rigor, Petitioner cites a dictionary definition that defines a “function” as: “[a]variable quantity regarded in *relation to one or more other variables* in terms of which it may be expressed or on which its value depends.” Ex. 1064, 4 (emphasis added).

Thus, although we discern no need to expressly construe the phrase “function of,” as used in the claims, we determine the claims are at least as broad as to encompass functions of one or more input variables to determine the value of a generated (output) value.

C. Legal Principles of Obviousness

A patent claim is unpatentable under 35 U.S.C. § 103(a) if the differences between the claimed subject matter and the prior art are “such that the subject matter[,] as a whole[,] would have been obvious at the time the invention was made to a person having ordinary skill in the art to which said subject matter pertains.” *KSR Int’l Co. v. Teleflex Inc.*, 550 U.S. 398, 406 (2007). The question of obviousness is resolved on the basis of underlying factual determinations, including: (1) the scope and content of the prior art; (2) any differences between the claimed subject matter and the prior art; (3) the level of skill in the art; and (4) objective evidence of non-obviousness, i.e., secondary considerations. *Graham v. John Deere Co.*, 383 U.S. 1, 17–18 (1966).

“In an [*inter partes* review], the petitioner has the burden from the onset to show with particularity why the patent it challenges is unpatentable.” *Harmonic Inc. v. Avid Tech., Inc.*, 815 F.3d 1356, 1363 (Fed.

Cir. 2016) (citing 35 U.S.C. § 312(a)(3) (requiring *inter partes* review petitions to identify “with particularity . . . the evidence that supports the grounds for the challenge to each claim”). This burden never shifts to Patent Owner. See *Dynamic Drinkware, LLC v. Nat’l Graphics, Inc.*, 800 F.3d 1375, 1378 (Fed. Cir. 2015) (citing *Tech. Licensing Corp. v. Videotek, Inc.*, 545 F.3d 1316, 1326–27 (Fed. Cir. 2008)) (discussing the burden of proof in *inter partes* review). Furthermore, Petitioner cannot satisfy its burden of proving obviousness by employing “mere conclusory statements.” *In re Magnum Oil Tools Int’l, Ltd.*, 829 F.3d 1364, 1380 (Fed. Cir. 2016).

Regarding the scope and content of the prior art, when considering the disclosures of a reference, “a reference must be considered not only for what it expressly teaches, but also for what it fairly suggests.” *In re Baird*, 16 F.3d 380, 383 (Fed. Cir. 1994) (quoting *In re Burckel*, 592 F.2d 1175, 1179 (CCPA 1979)).

In weighing secondary considerations, “[o]bjective evidence of nonobviousness can include copying, long felt but unsolved need, failure of others, commercial success, unexpected results created by the claimed invention, unexpected properties of the claimed invention, licenses showing industry respect for the invention, and skepticism of skilled artisans before the invention.” *Power Integrations, Inc. v. Fairchild Semiconductor Int’l, Inc.*, 711 F.3d 1348, 1368 (Fed. Cir. 2013) (citing *In re Rouffet*, 149 F.3d 1350, 1355 (Fed. Cir. 1998)). “These objective considerations can protect against the prejudice of hindsight bias, which often overlooks that ‘[t]he genius of invention is often a combination of known elements which in hindsight seems preordained.’” *Id.* (quoting *McGinley v. Franklin Sports, Inc.*, 262 F.3d 1339, 1351 (Fed. Cir. 2001)). “[E]vidence of secondary

considerations may often be the most probative and cogent evidence in the record.” *Stratoflex, Inc. v. Aeroquip Corp.*, 713 F.2d 1530, 1538 (Fed. Cir. 1983).

We analyze the instituted ground of unpatentability with these legal principles as our guidance.

D. Level of Ordinary Skill in the Art

Though not cited in Petitioner’s briefings, Dr. Madisetti, Petitioner’s expert, opines that the person of ordinary skill would have a Bachelor’s degree in electrical engineering (or a related field) with at least two years of experience in the design of “power electronics” or, alternatively, a Master’s degree in electrical engineering or a related field. Ex. 1003 ¶ 38. Neither Patent Owner nor Mr. Bohannon (Patent Owner’s technical expert) comment on the skills of an ordinarily skilled person in this art.

We find Dr. Madisetti’s unrebutted definition of the level of ordinary skill in this field is reasonable and adopt it as our own. Furthermore, we note that the applied prior art also reflects the appropriate level of skill at the time of the claimed invention. *See Okajima v. Bourdeau*, 261 F.3d 1350, 1355 (Fed. Cir. 2001).

E. Secondary Considerations

Patent Owner argues the commercial success of its TOPSwitch-GX products (hereinafter “GX”) and Petitioner’s adjudged infringing products¹⁰

¹⁰ Patent Owner refers to products of System General Corporation (“SG”) and Fairchild, which have been adjudged to infringe the ’079 patent and which, by virtue of completion of the merger, are attributable to the Petitioner.

provides objective evidence of non-obviousness. PO Resp. 52–58.

According to Patent Owner’s declarant Mr. David Michael Matthews, Patent Owner’s Vice President of Product Development, the GX products have sold over 300 million units and Petitioner’s infringing products have sold more than 400 million units. *Id.* at 52 (citing Ex. 2032 ¶ 19).¹¹ Patent Owner’s Response proffers a sales volume chart as evidence in support of its commercial success assertion. *Id.* at 56. The chart, provided in Mr. Matthews’ Declaration,¹² is reproduced below.

¹¹ Patent Owner proffers Mr. Matthews not as an expert witness but as a fact witness. Ex. 1072, 22 (“This witness [(Mr. Matthews)] is here to provide testimony on facts, the facts in his declaration, related to his personal experience, not to provide legal opinions for you on something he has never opined on.”).

¹² Mr. Matthews testified that he did not produce the chart and he did not know who did produce the chart. Ex. 1072, 26. However, Mr. Matthews further testified that he reviewed the raw sales data for the products represented by the chart and, apparently, validated that information. *Id.* (“Q. Did you do anything as part of preparing your declaration to confirm that this chart is accurate? . . . A. I reviewed the sales data for these products.”).

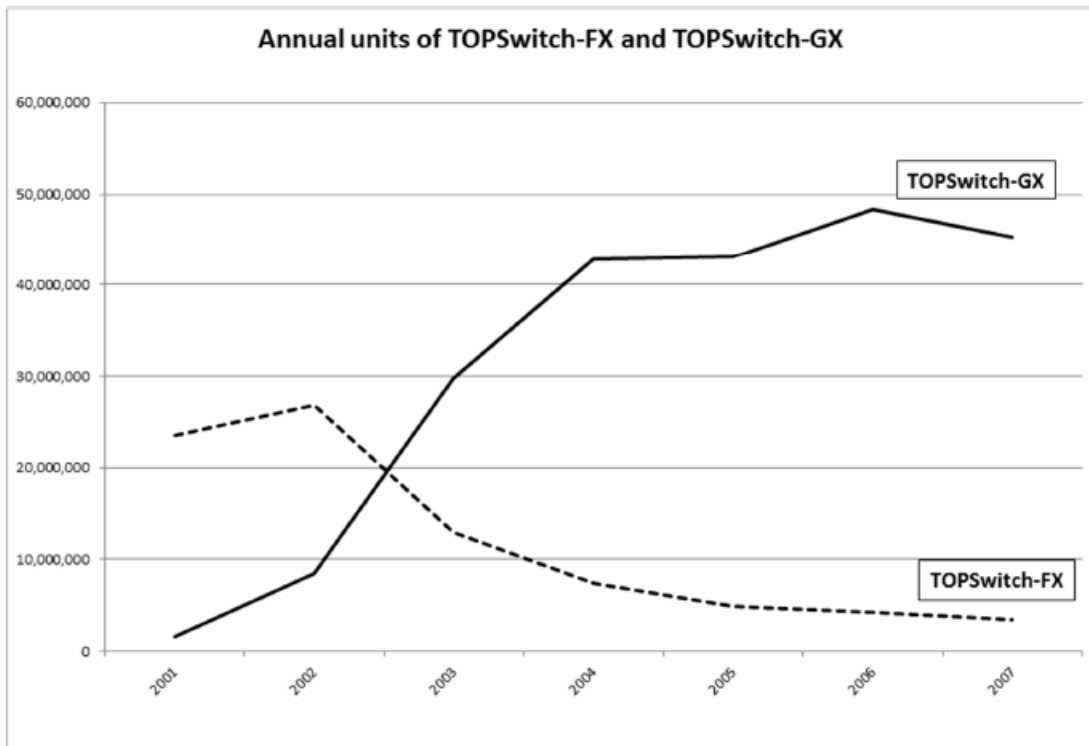

Mr. Matthews’ chart shows annual sales of Patent Owner’s GX products, alleged to embody the claimed invention, as compared with its TOPSwitch-FX (hereinafter “FX”) products allegedly devoid of the claimed invention. PO Resp. 56 (citing Ex. 2032 ¶ 30).

Patent Owner further asserts “there is a strong nexus between this success and the claimed invention; evidence, including interactions with customers who stated they bought the products *because of the patented invention* shows this success was directly, if not solely, tied to the technology of the challenged claims.” *Id.* at 52. Patent Owner further asserts there is a presumption of a nexus when objective evidence (customers’ reasons for their purchase) is tied to a product that is the claimed

invention. *Id.* at 52–53 (citing *WBIP, LLC v. Kohler Co.*, 829 F.3d 1317, 1329–30 (Fed. Cir. 2016)).¹³

I. Nexus

The presumption of nexus asserted by Patent Owner is rebuttable: a patent challenger may respond by presenting evidence that shows the proffered objective evidence was “due to extraneous factors other than the patented invention.” *Demaco Corp. v. F. Von Langsdorff Licensing Ltd.*, 851 F.2d 1387, 1393 (Fed. Cir. 1988). Such extraneous factors include additional unclaimed features and external factors, such as improvements in marketing. *See, e.g., Ecolochem, Inc. v. S. Cal. Edison Co.*, 227 F.3d 1361, 1378 (Fed. Cir. 2000) (applying presumption even though commercial embodiment had unclaimed mobility feature); *Ormco Corp. v. Align Tech., Inc.*, 463 F.3d 1299, 1312 (Fed. Cir. 2006) (holding that evidence that commercial success was due to unclaimed or non-novel features of device “clearly rebuts the presumption that [the commercial product’s] success was due to the claimed and novel features”). However, a patent challenger

¹³ Patent Owner cites portions of Mr. Matthews’ Declaration, which discuss his recollection of customer feedback, including their motivation for purchasing decisions, in support of its argument. *See* PO Resp. 53–54 (citing Ex. 2032 ¶¶ 22–27). As discussed below in addressing Petitioner’s motion to exclude, we exclude such statements (in Mr. Matthews’ Declaration) as hearsay. Nonetheless, we note that even if we consider this testimony regarding customer feedback, it would not impact our conclusion in view of the record evidence, discussed below, that undermines a showing of nexus, including Patent Owner’s sales chart comparing FX and GX sales, the existence of additional members of the GX family providing higher power capabilities, and conflicting testimony from Patent Owner’s witnesses regarding features that were important to customers.

cannot successfully rebut the presumption with argument alone — it must present evidence. *Brown & Williamson*, 229 F.3d at 1130 (citing *Demaco*, 851 F.2d at 1393).

Petitioner argues the sales volume difference between the FX and GX products, shown in Mr. Matthews' chart, can be explained by other differences between the FX and GX products. Pet. Reply 22. For example, Petitioner argues the FX family of products included only three products with varying wattage ratings while the GX family of products included products with the same three wattage ratings plus six additional products with higher wattage ratings for higher power applications. *Id.* (citing Ex. 1061 ¶¶ 52–61).

Petitioner also argues a table in Patent Owner's data sheet for the GX family of products lists numerous differences between the FX family and the GX family. *Id.* at 22–23. The table is reproduced below.

Function	TOPSwitch-FX	TOPSwitch-GX	TOPSwitch-GX Advantages
Light Load Operation	Cycle skipping	Frequency and duty cycle reduction	<ul style="list-style-type: none"> Improves light load efficiency Reduces no-load consumption
Line Sensing/Externally Set Current Limit (Y, R and F Packages)	Line sensing and externally set current limit mutually exclusive (M pin)	Line sensing and externally set current limit possible simultaneously (functions split onto L and X pins)	<ul style="list-style-type: none"> Additional design flexibility allows all features to be used simultaneously
Current Limit Programming Range	100% to 40%	100% to 30%	<ul style="list-style-type: none"> Minimizes transformer core size in highly continuous designs
P/G Package Current Limits	Identical to Y package	TOP243-246 P and G packages internal current limits reduced	<ul style="list-style-type: none"> Matches device current limit to package dissipation capability Allows more continuous design to lower device dissipation (lower RMS currents)
Y/R/F Package Current Limits	100% (R and F package N/A*)	90% (for equivalent $R_{DS(ON)}$)	<ul style="list-style-type: none"> Minimizes transformer core size Optimizes efficiency for most applications
Thermal Shutdown	125 °C min. 70 °C hysteresis	130 °C min. 75 °C hysteresis	<ul style="list-style-type: none"> Allows higher output powers in high ambient temperature applications
Maximum Duty Cycle Reduction Threshold	90 μ A	60 μ A	<ul style="list-style-type: none"> Reduces output line frequency ripple at low line DC_{MAX} reduction optimized for forward designs using TOP248, TOP249 and TOP250
Line Under-Voltage Negative (turn-off) Threshold	N/A*	40% of positive (turn-on) threshold	<ul style="list-style-type: none"> Provides a well defined turn-off threshold as the line voltage falls
Soft-Start	10 ms (duty cycle)	10 ms (duty cycle + current limit)	<ul style="list-style-type: none"> Gradually increasing current limit in addition to duty cycle during soft-start further reduces peak current and voltage Further reduces component stresses during start up

Table 5 of Patent Owner’s data sheet for the GX family of products lists nine functions (features) of switched power supply controllers, describes the difference in each function between its implementation in the FX family and the GX family, and describes the advantages of the GX product as compared to the FX products for each of the nine functions. Petitioner argues each of these differences provide important advantages of the GX products as compared to the FX products and only the first listed function represents the claimed invention. *Id.* at 23.

Petitioner also contends Patent Owner’s assertions of the reasons customers choose the GX products have changed over time. *Id.* at 23–24. Mr. Matthews testifies in his Declaration that the claimed features (variable

on-time with varying frequency) was the “key driver (if not the sole driver) of customer purchases.” *Id.* (quoting Ex. 2032 ¶ 27). However, Petitioner observes that Mr. Matthews previously testified in a trial that the features customers liked about the GX products varied on a customer-by-customer basis. *Id.* at 24 (citing Ex. 1075, 6). In still other sworn trial testimony, Mr. Bruce Renouard, Patent Owner’s Vice President of Worldwide Sales, “testified that ‘softstart’ and ‘frequency jitter’ were ‘key’ features of the GX family” and that frequency jitter was the “‘granddaddy’ of the features that drove sales” of the GX products. *Id.* (quoting Ex. 1071, 9, 12). Such conflicting testimony diminishes the weight we ascribe to Mr. Matthews’ testimony regarding key features driving customer purchase decisions.

We find Patent Owner’s sales chart comparing FX and GX sales weighs against Patent Owner’s assertion of a nexus between sales of the GX products (or Petitioner’s infringing products) and the features of the claimed invention — varying frequency and on-time. Further, the existence of additional members of the GX family providing higher power capabilities could have been a significant factor in success of the GX family rather than the claimed feature of varying both frequency and on-time. Moreover, conflicting sworn testimony by Patent Owner’s witnesses regarding features that were important to customers in choosing the GX products weighs further against Patent Owner’s assertion of a nexus between success of the GX products and the claimed feature of varying both pulse frequency and on-time. The preponderance of the evidence indicates numerous other features of the GX products account for their success in addition to the features of the claimed invention and, thus, we determine Patent Owner has failed to establish the required nexus.

2. *Commercial Success*

Even if we were to presume a nexus between success of the GX products and the claimed invention of the '079 patent, Petitioner argues Patent Owner's evidence of commercial success is insufficient because it fails to provide evidence of market share. Pet. Reply 27–28. “An important component of the commercial success inquiry . . . is determining whether [Patent Applicant] had a significant market share relative to all competing [products and companies] based on the merits of the claimed invention, which [Patent Applicant] did not show.” *See In re Applied Materials, Inc.*, 692 F.3d 1289, 1300 (Fed. Cir. 2012); *see also In re Huang*, 100 F.3d 135, 140 (Fed. Cir. 1996) (“The more probative evidence of commercial success relates to whether the sales represent a substantial quantity in th[e] market.”).

Petitioner argues Patent Owner's evidence of commercial success shows only a comparison between two of Patent Owner's products — the FX and GX products. Pet. Reply 28. We agree. Mr. Matthews' chart, reproduced *supra*, demonstrates a difference in sales between the FX and GX products but excludes numerous other products of Patent Owner let alone products of other manufacturers in the same product area. For example, Mr. Matthews does not consider the sales volumes of Patent Owner's other families of switched power supply controllers. Ex. 1072, 26–27 (original transcript pages 101–102). Although mentioning the approximate sales volume of Petitioner's infringing products (Ex. 2032 ¶ 37), Mr. Matthews provides no data regarding other products by Petitioner or other competitors in the same industry. Mr. Balu Balakrishnan, Patent

Owner's CEO and co-inventor of the '079 patent, testifies that earlier products of Patent Owner, devoid of the claimed invention, were "even more successful than TopSwitch FX and GX." Pet. Reply 28 (quoting Ex. 1070, 3:23–4:3). This conflicting testimony of Patent Owner's CEO diminishes the weight we ascribe to Mr. Matthews' chart because, at least, other "even more successful" products of Patent Owner are not included in the chart to demonstrate the true market share of the GX products. Patent Owner's evidence of commercial success fails to account for these other products as a portion of the relevant market.

Without evidence of market share, we have no way to determine the impact that the GX product family had on a specific market, and hence, its commercial success as objective evidence of non-obviousness.

3. Conclusions Regarding Secondary Considerations

Patent Owner has not addressed any aspects of secondary considerations other than commercial success. For the above reasons, the preponderance of the evidence fails to persuade us of commercial success of the GX products as indicative of non-obviousness of the claims of the '079 patent. In particular, the evidence of commercial success lacks any evidence of market share against which to judge the success of the GX products asserted to embody the claimed invention. Further, the evidence of nexus similarly weighs against a conclusion that, whatever success was realized by the GX products, is attributable to the claimed invention as opposed to numerous other features touted by Patent Owner (in its tabular comparison of the FX and GX products and in conflicting testimony of Patent Owner's witnesses here and in earlier trial proceedings). In

particular, the conflicting testimony of Mr. Matthews regarding customers' feedback characterizing the basis for purchasing the GX products diminishes the weight to be ascribed to Patent Owner's evidence of a nexus between the claimed invention and the alleged commercial success of the GX products.

F. Scope and Content of Prior Art Relied Upon

1. Oda (Ex. 1029)

Oda discloses a switched power supply converter switching structure that controls pulse width (Ex. 1029 ¶ 8) and pulse frequency (*id.* ¶ 12). In general, a step-down DC-DC converter (as disclosed in Oda) converts a DC input voltage into a pulsed voltage to supply a stepped down output voltage to a load. *Id.* An error detection circuit detects a difference between the generated, pulsed output voltage and a reference voltage and, based on the detected difference, which varies based on the level of load receiving the output voltage, varies the pulse width and pulse frequency to reduce the detected difference. *See id.* ¶¶ 8–12. Figure 1 of Oda is reproduced below.

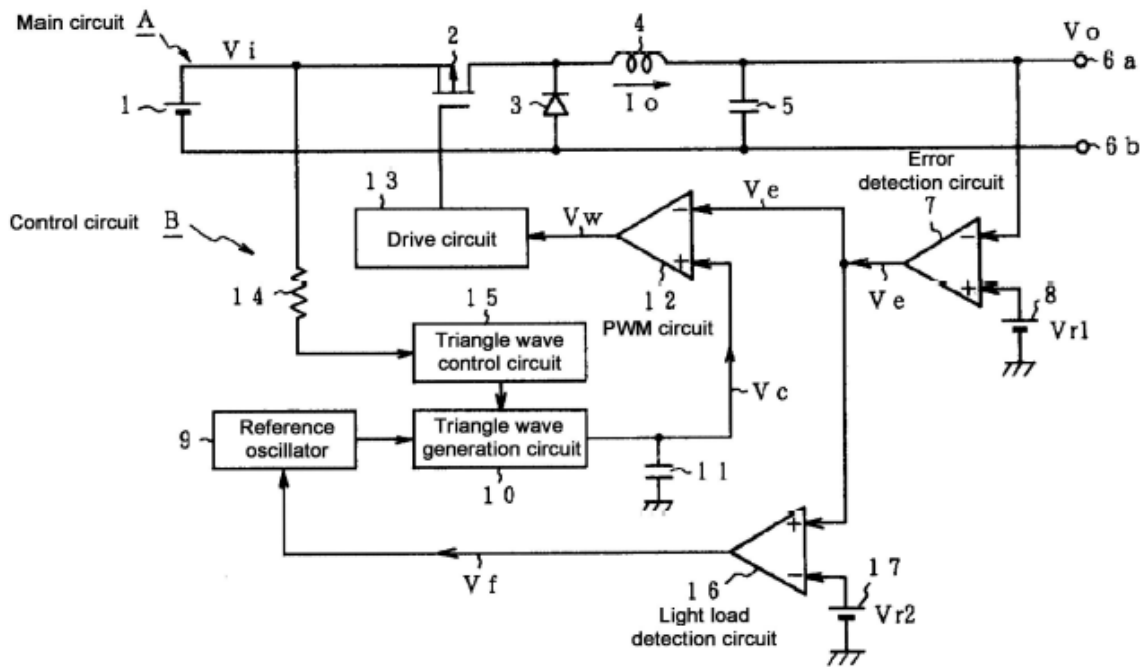
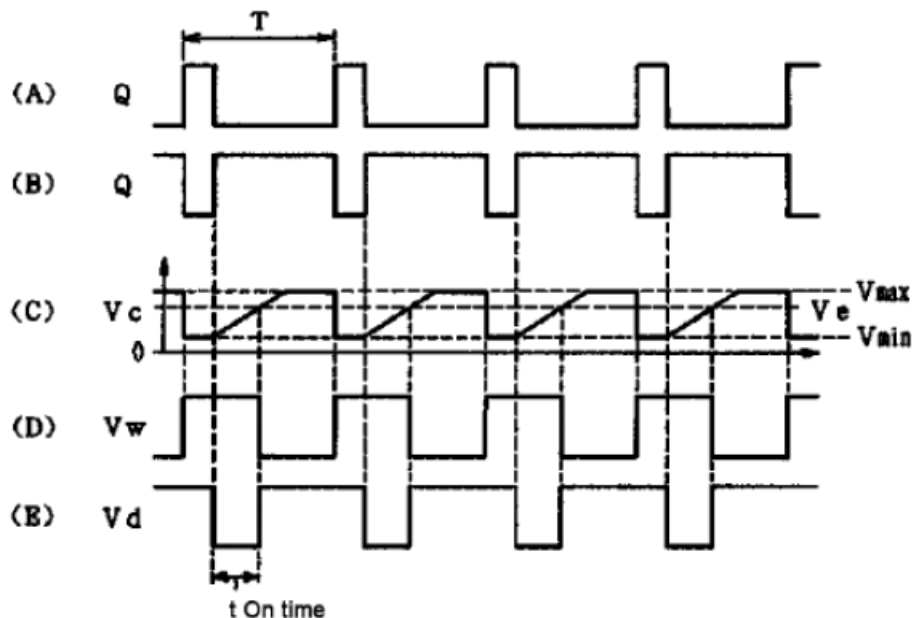

FIG. 1

Figure 1 of Oda discloses a step-down, DC-DC converter (a so-called “buck type” converter) that uses voltage source 1, generating input voltage (V_i), to provide a regulated, lower, output voltage (V_o) between nodes 6a and 6b. *See id.* ¶ 13. Switch (field-effect transistor (“FET”)) 2 is controlled by drive circuit 13 to switchably apply current (I_o) from voltage source 1 to capacitor 5 through inductor (“choke coil”) 4. *See, e.g., id.* ¶¶ 13–15. Error detection circuit 7 compares V_o with reference voltage source 8 (V_{r1}) and generates error voltage (V_e) applied to pulse-width modulation (“PWM”) circuit 12. *Id.* ¶ 15. PWM circuit 12 receives V_e and triangle wave voltage V_c and generates V_w applied to drive circuit 13 to adjust the pulse width (on-time) of pulses applied to switch 2, which, in turn, pulses application of the input voltage (V_i) to choke coil 4. *See id.* In addition, V_e is applied to light load detection circuit 16 for comparison with reference voltage source 17 (V_{r2}) to generate V_f applied to reference oscillator 9 to adjust the

frequency of pulses applied to switch 2 (e.g., by changing the frequency of the triangle wave signal applied to PWM circuit 2). *See, e.g., id.* ¶¶ 25–29.

Oda's Figure 3, reproduced below, explains the operation of its regulator in controlling pulse width and on-time.



Lines (A) and (B) of Oda's Figure 3 represent the outputs of reference oscillator 9 of Figure 1 as applied to triangle wave generator 10. Ex. 1029 ¶ 17. Triangle wave generator 10 generates triangle wave V_c based on parameters provided by triangle wave control circuit 15 (responsive to the feed-forward signal sensed as input voltage V_i through resistor 14). *Id.* ¶¶ 16, 19. V_c rises from V_{min} to V_{max} (line (C)) at a rate (gradient) determined by control parameters of control circuit 15. *Id.* ¶ 20. The on-time ("t") of each pulse of V_d (line (E)) is determined by comparing the rising voltage V_c with the present value of V_e . *Id.* ¶ 19. Thus, as V_e changes, representing changes in the present load on the power supply, V_c will cross the V_e threshold sooner (a lower level of V_e will shorten the

on-time for a light load) or later (a higher level of V_e will lengthen the on-time for a heavier load). *Id.* ¶¶ 21–22.

Oda is principally directed to an improved power supply in which, by sensing changes in input voltage V_i (feed-forward), the pulse width may be adjusted (in addition to the adjustments to pulse width above in response to a changing load on the power supply reflected by changes in V_e). *See id.* ¶¶ 8–9. Thus, the feed-forward mechanisms of Oda varies the gradient of the triangle waveform V_c , which also affects the pulse on-time generation described above. *See id.* ¶¶ 9, 11. As the gradient of V_c is slowed, V_c will cross V_e later, thereby generating a longer on-time and, conversely, a faster gradient of V_c will shorten the pulse on-time. Therefore, the pulse on-time in Oda may be said to be a “function of” two variables — V_c and V_e — because changes in either V_c or V_e effectuate a change in the generated pulse on-time.

2. *Nakamura (Ex. 1050)*

Nakamura discloses a switched power supply converter, the object of which is to increase the range of control for switching of the charging operation. *See Ex. 1050, 3–4.* Nakamura discloses “along with the width of the control pulse being narrowed, the cycle of the control pulse is enlarged, and therefore an effect that is equivalent to an apparent reduction of the accumulated time of the switching transistor is achieved, and the control range can be increased.” *Id.* at 5; *see also id.* at 6 (“[T]he control transistor (15) is used for both pulse width control and frequency control.”). Thus, Nakamura’s converter narrows the generated pulse (i.e., reduces the

on-time) and extends the pulse cycle (i.e., pulse period) to, thereby, alter both pulse on-time and pulse frequency.

Petitioner reproduces Nakamura Figures 4 and 8 (Pet. 23 and 30) with annotations as follows:

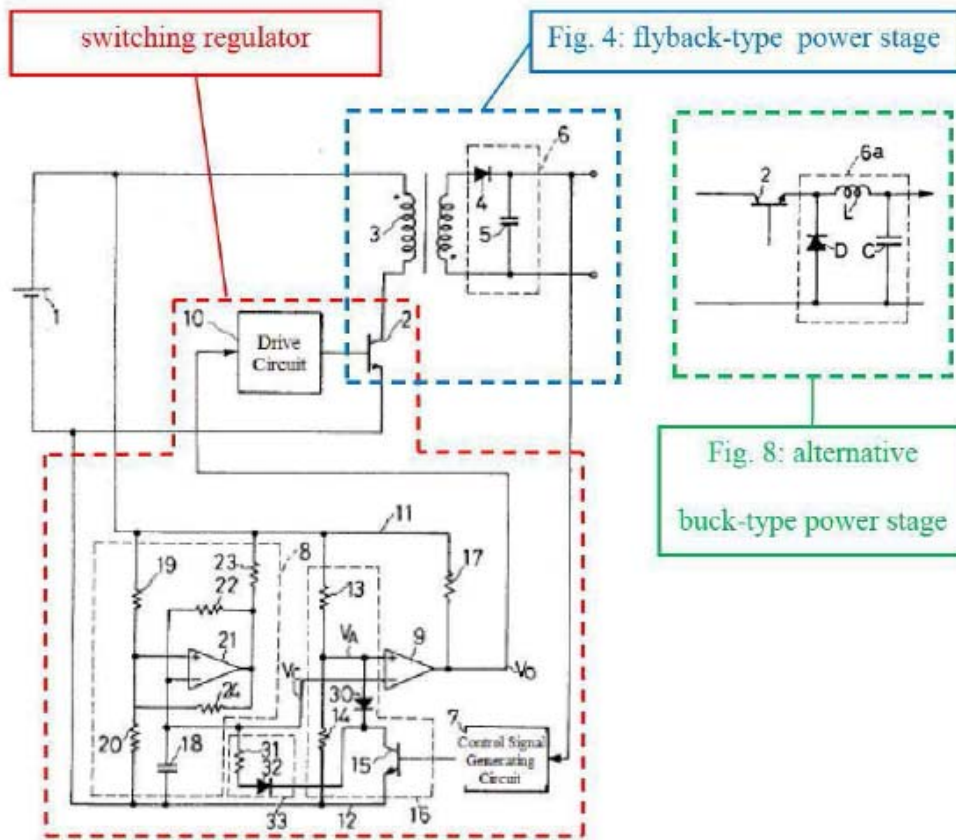

Nakamura's Figure 4, reproduced above with Petitioner's annotations, depicts a switching regulator coupled with a flyback topology power stage. *See Ex. 1050, 6; see also Pet. 23–24.* Nakamura's Figure 8, reproduced above with Petitioner's annotations, depicts a buck topology power stage. *See Ex. 1050, 6; see also Pet. 24–25.*

In general, control signal generating circuit 7 of the switching regulator senses the voltage at the output of the transformer and generates a control signal applied to control transistor 15. *See Ex. 1050, 3.* Control

transistor 15, in conjunction with other circuits of Figure 4, effects adjustments to the width and frequency (cycle) of pulses applied to drive circuit 10. *See id.* at 5–6. Drive circuit 10 turns switching transistor 2 on and off to apply or remove current at the primary winding of transformer 3 to charge or discharge (i.e., regulate) the output side of the transformer. *See id.*

As annotated by Petitioner, Nakamura Figure 4 depicts a switching regulator (components collectively encompassed by Petitioner’s annotation of red dashed lines) controlling power switch (switching transistor) 2 to controllably apply pulsed current to transformer primary winding 3 (a transformer in a flyback topology power stage encompassed by Petitioner’s annotation of blue dashed lines). Nakamura discloses an alternative embodiment in Figure 8 in which the flyback topology power stage may be replaced with a buck topology power stage (encompassed by Petitioner’s annotation of green dashed lines). *See id.* at 6 (“As shown in FIG. 8, the output of the switching transistor (2) can be applied to a switching regulator for smoothing with a smoothing circuit (6A) configured from a reactor L, a diode D, and a capacitor C without using an output transformer.”).

G. Asserted Obviousness over Oda and Nakamura

Petitioner identifies the recitations of each challenged claim in disclosures of Oda. Pet. 28–58. In particular, Petitioner argues the claimed “energy transfer element” reads on the buck topology inductor (choke coil 4) of Oda. *Id.* at 33–34. Consistent with its proposed construction of “energy transfer element” as encompassing both flyback topology transformers and buck topology inductors, Petitioner argues Oda alone discloses all the

claimed features, including the recited “energy transfer element.” *Id.* at 34. However, Petitioner further argues, if “energy transfer element” is construed more narrowly to exclude buck topology architectures and include only flyback architectures, use of a flyback architecture transformer “would nonetheless be disclosed and rendered obvious by the combination of Oda with the knowledge of a [person of ordinary skill in the art] and/or the teachings of Nakamura.” *Id.* Thus, Petitioner relies on Nakamura for disclosing that it was known at the time of the invention of the ’079 patent to use a switching regulator (i.e., a control circuit that controls the power switch) with either a buck topology power supply or a flyback topology power supply. *Id.* at 29–31.

1. Motivation to Combine Oda with Nakamura

Petitioner argues “Nakamura teaches that a switching regulator can be utilized with either a buck-type power stage or a flyback-type power stage. Ex. 1003 at ¶ 75.” Pet. 30. Petitioner further argues it was recognized in the art at the time the invention of the ’079 patent was made that a transformer (in a flyback topology) provided benefits over an inductor (in a buck topology). *Id.* Specifically, transformers in flyback topologies provide isolation between the input side of the converter/regulator and the output side thereof. *Id.* at 31 (citing Ex. 1034, 11 as evidence such benefits are common knowledge). Therefore, Petitioner contends,

Because the use of a transformer has well known advantages, and because Nakamura demonstrates that a switching regulator can be used with a transformer in a fly-back type power stage or an inductor in a buck-type power stage, a [person having ordinary skill in the art] would have been motivated to replace the buck-type power stage in Oda with a flyback-type power stage

as taught by Nakamura to achieve the benefits associated with using a transformer.

Id.

In its Preliminary Response, Patent Owner argued, “Petitioner offers absolutely no proof that the Oda switching regulator is one that would work and be compatible in both [b]uck and [f]lyback topologies.” Prelim.

Resp. 55. Patent Owner alleges that issue is not addressed by the Petition.

Id. Patent Owner does not raise this argument in its Response and, thus, this argument is deemed waived. Paper 13, 3 (“The patent owner is cautioned that any arguments for patentability not raised in the response will be deemed waived.”); *see also Cablz, Inc. v. Chums, Inc.*, No. 2016-1823 WL 4005589, at *3 (Fed. Cir. Sept. 12, 2017) (concluding that patent owner waived an argument that “it failed to raise . . . in its briefing before the IPR oral hearing”). Regardless, it remains Petitioner’s burden to articulate a reason for the proposed combination.

Nakamura discloses a switching regulator, similar in function to that of Oda, which uses either a buck or a flyback topology power stage. *See* Ex. 1050, 6 and Figs. 4, 8. Exhibit 1034, a book by Robert W. Erickson cited by Petitioner (Pet. 31), provides supporting evidence that ordinarily skilled artisans at the time of invention of the ’079 patent would have known the benefits of isolation when using a transformer. Ex. 1034, 11 (“In a large number of applications, it is desired to incorporate a transformer into a switching converter, to obtain dc isolation between the converter input and output.”). Petitioner argues, and we agree, “the substitution of different types of power-stage topologies represents the simple substitution of one known element for another to obtain a predictable result.” Pet. 31. Indeed, “when a patent ‘simply arranges old elements with each performing the

same function it had been known to perform' and yields no more than one would expect from such an arrangement, the combination is obvious." *KSR*, 550 U.S. at 417 (quoting *Sakraida v. Ag Pro, Inc.*, 425 U.S. 273, 282 (1976)).

Accordingly, we determine Petitioner has provided sufficient reasoning and evidence to support, by a preponderance of the evidence, its assertion that the ordinarily skilled artisan would have been motivated to modify Oda to utilize a flyback topology power stage as disclosed in Nakamura, in place of Oda's buck topology power stage.

2. *Varying Both Frequency and On-time During Second Range*

In accordance with our claim construction, all challenged claims require the on-time of generated pulses applied to the switch to be varied when the control circuit varies the frequency for the second range of feedback values. Petitioner argues Oda decreases the frequency of generated pulses when the error voltage (V_e – feedback signal) drops below a threshold value V_{r2} . Pet. 40–43. Petitioner further argues Oda varies the on-time of generated pulses as a function of V_e , which varies between V_{max} and V_{min} based on load. *Id.* at 48. Petitioner contends,

As shown in Figure 7, the range from V_{max} down to V_{min} includes both the first range of feedback signal values (V_e values above V_{r2}) and the second range of feedback signal values (certain V_e values below V_{r2}). Ex. 1029 at Fig. 7; Ex. 1003 at ¶ 95. Accordingly, the first range of feedback signal values (V_e values above V_{r2}) corresponds to a first range of on-time values, and the second range of feedback signal values (certain V_e values below V_{r2}) correspond to a second range of on-time values. Ex. 1029 at ¶¶ 0015, 0025, Figs. 3(A)-(E), 7; Ex. 1003 at ¶ 97.

Id. at 48–49. In other words, Petitioner asserts, in essence, that pulse on-time is varied as a function of the feedback signal V_e as it varies throughout its range of V_{min} to V_{max} . *See* Pet. 48–50. At the same time, as V_e varies between V_{min} and V_{max} , pulse frequency is fixed in a first range of such V_e values (above V_{r2} to V_{max}) and varies over a second range of V_e values (certain values below V_{r2}). *See id.*

There is no disagreement between the parties that Oda discloses that the pulse frequency is fixed in a first range of feedback signal values (V_e values above V_{r2}) and is varied in a second range of feedback signal values (certain V_e values below V_{r2}). The disagreement is whether Oda discloses varying pulse frequency and on-time in the same range. In support of its reading of Oda, Petitioner provides an annotated version of Oda’s Figure 8 with shadings to show the first and second ranges of feedback signal values (values of V_e) and the corresponding fixed and variable frequencies of generated pulses. Petitioner’s annotated Figure 8 is reproduced below with our annotation annotation in red to clarify the label “ V_{r2} ” on the x-axis.

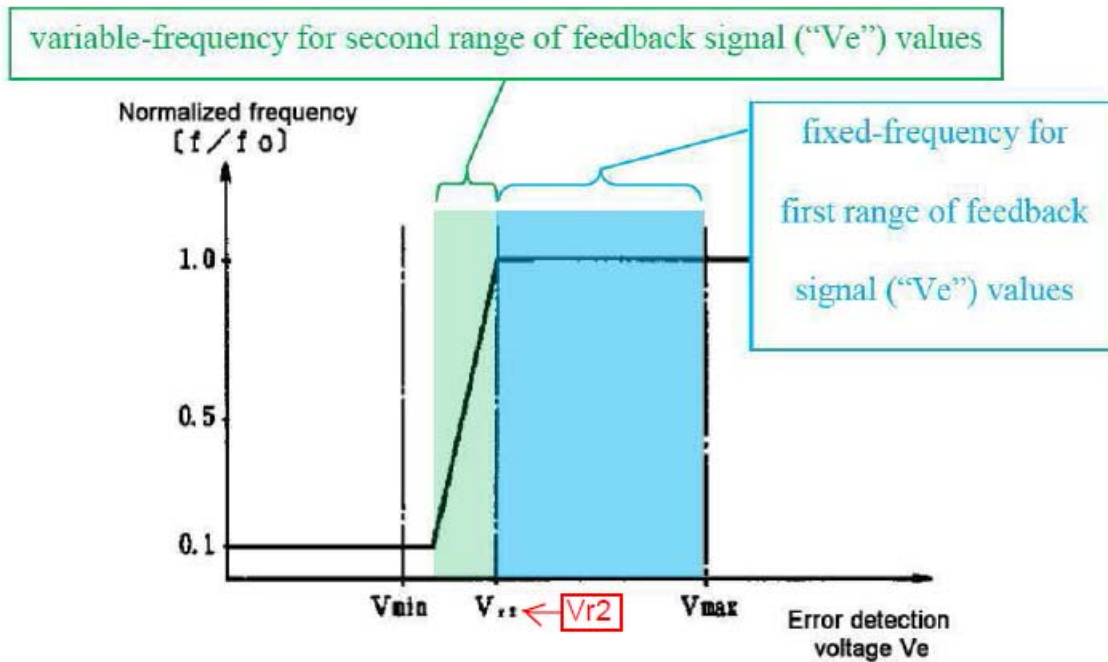

Petitioner’s annotated version of Oda’s Figure 8, reproduced above, is a line chart showing a normalized frequency (y-axis) as a function of error detection voltage (feedback signal – V_e on the x-axis). For feedback signals (V_e) greater than V_{r2} (highlighted with blue shading), the normalized frequency is fixed at 100% of its nominal frequency f_0 . Ex. 1029 ¶ 30. For a range of feedback signal values (V_e) less than V_{r2} (highlighted with green shading), normalized frequency is reduced to a minimum frequency of about 10% of its nominal frequency f_0 . *Id.* As shown in Oda’s Figure 8, once the normalized frequency is reduced to 10% of its nominal value f_0 , the normalized frequency is again fixed at 10% of its nominal frequency as the feedback value continues to drop to zero.

a. *Only Fixed Minimum Pulse On-Time Known in The Art*

Patent Owner argues, “Oda does not expressly or inherently address the relevant issue in this IPR of whether or not the V_e voltage causes the

drive signal ‘on time’ to vary at the same time it causes frequency to vary.” PO Resp. 22. Patent Owner further argues other prior art references at the time of Oda explicitly teach maintaining a constant (minimum) pulse on-time when frequency is varied. *Id.* at 22–23 (citing Ex. 1011, 5; Ex. 1012, 1:36-47, 2:60-62; Ex. 2031 ¶ 83); *see also id.* at 45–46. Patent Owner contends these prior art references and Oda’s disclosures in Figures 9 and 10 and paragraphs 4 and 5 confirm that light load detection circuit 16 of its invention in Figure 1 operates in the same manner as these known prior techniques such that frequency is varied *only* after a fixed minimum pulse width is reached. *Id.* at 23–24 (citing Ex. 2031 ¶ 84); *see also id.* at 46.

Patent Owner’s argument regarding the known state of the art at the time of Oda, allegedly confirming that Oda must operate in the same manner, is unavailing. Petitioner also characterizes the state of the art, including identifying other prior art references that simultaneously varied both frequency and pulse on-time. Pet. 9–15. In particular, Petitioner argues other prior art of record demonstrates that it was known at the time of Oda to allow both frequency and pulse on-time to vary at the same time. Pet. 14–15 (citing Ex. 1040, 632; Ex. 1047, 3:55–62). Petitioner further argues that Patent Owner’s own patent (U.S. Patent 5,602,724) issued three years prior to filing of the ’079 patent also discloses simultaneously varying both pulse on-time and frequency as a known technique. *Id.* at 15 (citing Ex. 1041, 3:37–42).

Thus, we are persuaded by Petitioner’s arguments and we find, by a preponderance of the evidence, that it was known in the state of the art at the time of Oda that pulse on-time could be varied at the same time as pulse

frequency is varied to control a switched power supply and that there was no requirement of a minimum fixed on-time when varying pulse frequency.

b. Oda At Least Suggests Varying Pulse On-Time And Frequency

In our Decision on Institution, we determined, based on the record at that preliminary stage, that Petitioner had not shown sufficiently that Oda expressly or inherently teaches that pulse on-time and frequency are both varied in the second range of feedback values as claimed. Dec. 27.

However, based on the record at that time, we determined Oda *at least* suggests such a feature. *Id.* On that preliminary record, we determined that “Petitioner has not identified sufficiently an express or inherent description that ‘certain V_e values’ will ever be encountered in Oda such that both on time and frequency will be varied in that second range of ‘certain V_e values.’” *Id.* Based on that determination we denied Petitioner’s ground of anticipation by Oda and proceeded with the present ground of obviousness over Oda in combination with Nakamura. *Id.* at 28.

Patent Owner argues our preliminary finding that Oda at least suggests varying the pulse on-time and frequency in the second range of feedback values “is irreconcilable with Oda’s disclosure.” PO Resp. 40. Patent Owner specifically asserts this is shown because the slope of a critical portion of the curve plotted in Oda’s Figure 7 is constant. *Id.* at 41. Patent Owner proffers an annotated version of Oda’s Figure 7, reproduced below, highlighting the portion of the graph it considers to a constant.

FIG. 7

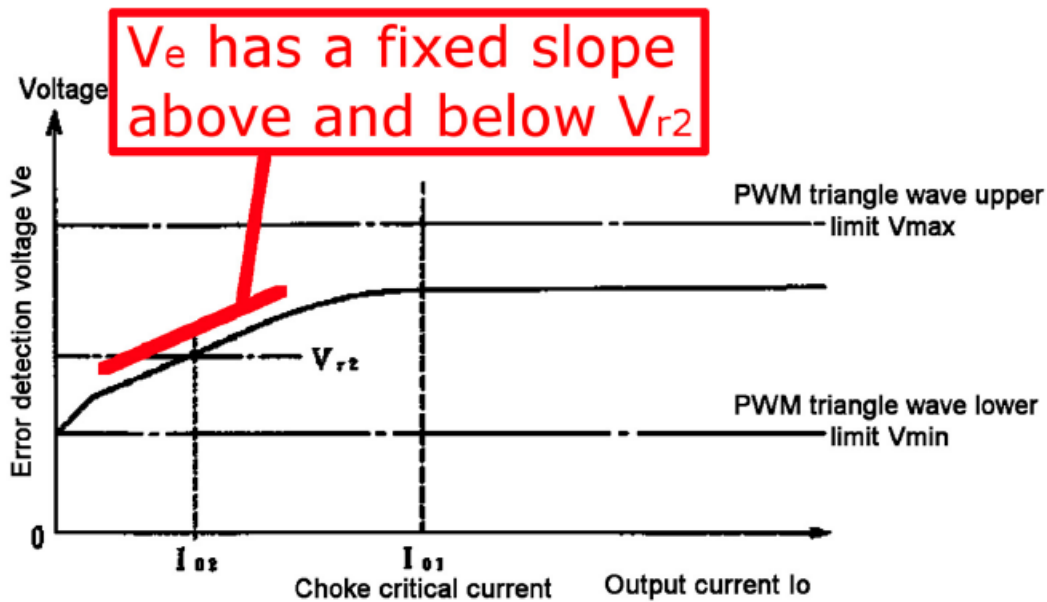

Patent Owner's annotated version of Oda's Figure 7, reproduced above, is a graph of error detection voltage (V_e on the y-axis) as a function of "choke critical current" at Oda's choke coil (coil 4 of Oda's Figure 1) shown along the x-axis. Portions of the plotted curve above and below V_{r2} , as annotated with a red line, are asserted to have a constant slope (i.e., a straight line). *Id.* at 41. Patent Owner argues,

Assuming, only for illustration purposes, one surmises that in Oda pulse width is varied with respect to V_e when frequency is varied, the *only* explanation for the lack of change in slope of the V_e curve at V_{r2} would be the gain of Oda's PWM operation must have one gain factor above V_{r2} and a different gain factor below V_{r2} .

Id. at 42–43 (citing Ex. 2031 ¶¶ 78–79) (emphasis added). Patent Owner asserts such a pulse width modulator with variable gain would be unconventional and not suggested to the ordinarily skilled artisan. *Id.* at 43. Patent Owner then contends the constant slope is easily understood "if one presumes that pulse width is held constant with respect to feedback when

frequency is varied.” *Id.* Patent Owner similarly identifies another portion of the graph of Oda’s Figure 7 that shows a change of slope that, allegedly, can only be explained by a fixed pulse on-time. *Id.* at 44–45. In view of these arguments, Patent Owner contends, contrary to our preliminary finding in the Decision on Institution, that Oda cannot even suggest to the ordinarily skilled artisan varying on-time at the same time as frequency and, instead, contends that the only plausible understating of the ordinarily skilled artisan in view of Oda’s Figure 7 is that pulse on-time is fixed in Oda, not variable, in the second range of feedback values. *Id.* at 45.

Patent Owner’s expert, Mr. Bohannon, argues the constant slope of Oda’s graph in Figure 7 just above and just below V_e at V_{r2} can only be explained by Oda’s PWM circuit 12 changing its gain to account for ending frequency adjustments below V_{r2} and he is unaware of any circuit with such a capability. Ex. 2031 ¶ 78. Mr. Bohannon further opines that if the on-time variation of Oda’s PWM circuit 12 were to continue operation even after V_e drops below V_{r2} (start of the second range of feedback values), another possible modification to change the gain of error detection circuit 7 could be envisioned but that such a circuit would, again, be unique in the art and would only be suggested with the benefit of hindsight of the ’079 patent. *Id.* ¶ 81. In the alternative, Mr. Bohannon suggests the only other approach would be to fix or clamp the pulse width modulation circuit (forcing a fixed on-time) and adjust the gain of the frequency modulation related circuits to adjust frequency in a different manner accounting for the fixed pulse on-time in the second range of feedback value. *Id.* ¶ 82. Mr. Bohannon contends this last alternative (referred to as “scenario 2”) is “the only reasonable

conclusion to be drawn from Figures 7 and 8 and the operation of the circuit.” *Id.* ¶ 83.

Petitioner replies that Patent Owner’s arguments and those of Mr. Bohannon are flawed because they overlook parameters of the graph of Oda’s Figure 7 that represent the operation of the power supply as a whole as compared to the graph of Figure 6 of Oda that relates only to the operation of the control circuit in isolation from the power supply as a whole. Pet. Reply 9. Specifically, Petitioner argues the graph of Figure 7 depicts the operation of the power supply as a whole and, thus, includes effects of the “transfer function of the buck-type power stage.” *Id.* at 9–10. Petitioner provides a detailed discussion of the effects of the transfer function of a buck converter based on its expert’s Reply Declaration. *Id.* at 10–14 (citing Ex. 1061 ¶¶ 29–36). Dr. Madisetti’s Reply Declaration discusses at length the transfer function effects of a buck-type converter applying teachings of the Mohan reference, a textbook on the subject. Ex. 1061 ¶¶ 29–36 (citing portions of Ex. 1081). Petitioner notes that Patent Owner’s expert, Mr. Bohannon, admitted that he had not considered the transfer function of the buck-type converter in his analysis of the alleged constant slope portion of Oda’s Figure 7. Pet. Reply 10, n.2 (citing Ex. 1073, 45).

Petitioner further replies to Mr. Bohannon’s speculation that the pulse on-time would be in some manner clamped or fixed by operation of PWM circuit 12 of Oda. Pet. Reply 14–16. Specifically, Petitioner argues that if the on-time generated by Oda were clamped at a minimum value, as suggested by Mr. Bohannon, Oda’s circuit would no longer function properly to adjust for both input voltage variations (feed-forward) and for

output load variations. *Id.* Petitioner's expert, Dr. Madisetti, further details reasons such a clamping scenario is not expressed or suggested by Oda. Ex. 1061 ¶¶ 13–19.

We discern no need to determine which of these detailed technical explanations of the alleged constant slope portion of the plotted curve of Figure 7 is the correct answer or even if other answers are possible or reasonable mathematically or practical from an electrical engineering perspective. Initially, we question whether the alleged constant slope is at all constant. Specifically, we have no basis to understand Figure 7 to be a mathematically precise plot of any function but, instead, appears to be a roughly drawn estimation intended to suggest a function of choke coil current that determines a corresponding error voltage V_e . During Dr. Madisetti's cross-examination, Patent Owner's counsel and Dr. Madisetti engaged in a lengthy discussion as to whether the portion of the plotted curve of Oda's Figure 7 is a straight line (constant slope) or a point where two curves join (in response to a transition from fixed frequency pulses to variable frequency pulses). Ex. 2065, 40:4–45:18. Dr. Madisetti concludes this discussion answering: "I would say that from the viewpoint of [an ordinarily skilled artisan] would understand that these are representations of portions of curves based on a discontinuous operation, so you would have to apply the teachings of discontinuous operations which is what Mr. Bohannon did not." *Id.* at 44:25–45:5.

Patent Owner's attempt to explain engineering solutions to achieve the precise plot of Figure 7, when there is no evidence of record that the plot is intended to represent any precise mathematical function or engineering results, seems futile (at best). Regardless, Dr. Madisetti opines that the

transfer function of such a coil can explain the shape of the curve in Figure 7 on either side of the V_{r2} threshold value of V_e . Mr. Bohannon, for unexplained reasons, did not consider the effects of the transfer function of a buck-type converter in explaining the plotted graph in Figure 7 of Oda although he acknowledged he was aware “there is a mathematical formula that goes along with it.” *See* Ex. 1073, 45.

At the oral hearing, Patent Owner’s counsel argued that Mr. Bohannon would have answered that the transfer function of a buck converter would not have made a difference in his analysis of Oda’s Figure 7:

[COUNSEL FOR PATENT OWNER]: So, the fact that there’s a buck output stage doesn’t have any impact on the transfer function of figure 7.

[THE BOARD]: And your expert has said that on the record?

[COUNSEL FOR PATENT OWNER]: Our expert said he didn’t apply the mathematics to calculate the transfer function of a buck converter because it’s not relevant to the analysis.

[THE BOARD]: What if he had? What if we conclude that it is relevant to the analysis? Do we have anything on your side of the case that says that even with the buck converter transfer function taken into account, that that would not produce the kind of straight line that you rely on here?

[COUNSEL FOR PATENT OWNER]: Your Honor, we actually wanted to put that into evidence because Mohan was raised for the first time in the reply and the Board refused to allow it. So, yes, my expert has said and would say that taking it into account does not change the situation, that the only way figure 7 can be explained is either that there are variable gains in the circuit, which nobody suggests that’s plausible, or it’s PWM above V_{r2} and pulse frequency control below V_{r2} .

Tr. 47:20–48:19. Patent Owner, however, cannot claim surprise by this position. As noted above, Mr. Bohannon was cross-examined about the effect of the transfer function of a buck-type converter on the shape of the curve of Oda’s Figure 7 and provided no such answer. *See* Ex. 1073, 45. Further, the Mohan textbook, relied on by both parties as background technical material well-known to ordinarily skilled artisans, was first introduced by Patent Owner as Exhibit 2017. Patent Owner referred to Mohan to discuss the advantages of a flyback converter as compared to the buck-type converter of Oda. Prelim. Resp. 25, 27. Thus, the Mohan reference was not only known to Patent Owner, but relied upon in the Preliminary Response. Although Mr. Bohannon never refers to Mohan in his testimony, we do not find credible the suggestion that he was unaware of the reference.

Although we acknowledge both Dr. Madisetti and Mr. Bohannon as experts in the relevant art, on this point of interpreting Oda’s Figure 7, we credit Dr. Madisetti’s experience and testimony over that of Mr. Bohannon. Dr. Madisetti explains the plotted curve of Oda’s Figure 7 with respect to the transfer function of a buck-type converter — i.e., choke coil 4 of Oda’s Figure 1 as opposed to Mr. Bohannon’s speculation that the *only* plausible explanation is that Oda does not operate as claimed in the ’079 patent. Dr. Madisetti has presented an alternative explanation that is unrebutted by Mr. Bohannon’s expert opinion.

More to the point, our decision is based on what is *suggested* by Oda to the ordinarily skilled artisan — not any precise disclosure of a function or a circuit that produces the precise plot of Figure 7. Oda must be read for what it fairly suggests, not just its express teachings. *Baird*, 16 F.3d at 383.

After all, “[a] person of ordinary skill is also a person of ordinary creativity, not an automaton.” *KSR*, 550 U.S. at 421. Nowhere does Oda indicate the plot of Figure 7 is a necessary outcome of its proposed design. Nor does Oda teach or suggest that there is a minimum on-time generated by PWM circuit 12 but instead discloses, or at least suggests, that pulse on-time is varied through all ranges of the V_e feedback signal without limitation.

On this record, we determine that Oda at least suggests to one of ordinary skill in the art that there is a range (a second range) of feedback values (certain V_e values below V_{r2}) during which both the on-time of pulses applied to the switch (FET 2) and the frequency of those pulses are varied.

c. Conclusion Regarding Varying Both Frequency and On-Time

For the above reasons, we determine by a preponderance of the evidence that Oda reasonably suggests a second range of feedback values in which both pulse frequency and on-time are varied.

3. Reliability of Translation Of Oda

Patent Owner argues Petitioner cannot meet its burden of proof because the translation of Oda it relies upon (Ex. 1029) is unreliable. PO Resp. 47. Specifically, Patent Owner argues the translation by Mr. Kent Johnson, which Petitioner provided and relies upon, is not independent and, instead, appears “‘guided’ by someone toward a theme favorable to Petitioner.” *Id.* (citing Ex. 2013 ¶¶ 108–113); *see* Ex. 1028. By way of example, Patent Owner argues Mr. Johnson’s footnote on page 10 of the Oda translation (Ex. 1029) requires technical knowledge that Mr. Johnson

lacks. *Id.* Mr. Bohannon, Patent Owner's technical expert, claims to be fluent in Japanese and asserts there are many errors in Mr. Johnson's translation. Ex. 2031 ¶¶ 108–113.

Petitioner replies that Patent Owner fails to identify any error that amounts to a substantive difference between Mr. Johnson's translation (Ex. 1029) and another translation provided by Patent Owner (Ex. 2048). Pet. Reply 28. Petitioner further notes that Mr. Bohannon admits he is not a certified translator. *Id.* at 29 (citing Ex. 1073, 15). We agree with Petitioner that Mr. Bohannon is not qualified as an expert in translation and we therefore do not credit his testimony about perceived errors in the certified translations provided by the parties.

We are not persuaded of any errors in Mr. Johnson's translation that impact our Decision in any substantive manner. The exemplary alleged error in a footnote that Patent Owner identifies as improper merely identifies an apparent typographic error in the original Japanese version. We perceive that no technical expertise is required to look at the figure being described, as a normal aspect of the translation process we would imagine, and see that the Japanese being translated does not match the figure. Furthermore, Patent Owner did not avail itself of an opportunity to cross-examine Mr. Johnson to inquire regarding his independence in the translation process or the basis for any alleged errors in his translation.

Accordingly, we are not persuaded by the preponderance of the evidence that this Petition should be dismissed or denied based on alleged translation errors by Mr. Johnson.

4. “*Corresponds to*” and “*Function of*”

Patent Owner argues Oda fails to meet the recited relationships between the first and second ranges of feedback values and the first and second ranges of on-time values. PO Resp. 47–52. Specifically, Patent Owner argues claims 31, 32, 38, and 39 require “non-overlapping subsets of on-time values and ‘feedback signal.’” *Id.* at 48. Patent Owner further argues claims 34 and 42 require the on-time and off-time values of pulses “vary as a ‘function of’ an output-related value, and thus there must be exactly one value of on-time and one value of off-time for any given output-related value.” *Id.* These arguments are based on Patent Owner’s proposed interpretation of “corresponds to” and “function of” — interpretations we rejected as unduly narrow. *See* sections II.B.3–4 above.

Based on Patent Owner’s proposed interpretation of “corresponds to,” Patent Owner contends claims 31 and 38 (and their respective dependent claims) require “non-overlapping subsets of on-time values and ‘feedback signal,’ and thus it cannot be possible for a given feedback signal value to result in an on-time value that is in the first range in some cases but in the second range in other cases.” *Id.* at 50. In like manner, based on Patent Owner’s proposed interpretation of “function of,” Patent Owner contends claims 34 and 42 require “that the drive signal on-time/off-time values vary as a ‘function of’ an output-related value, and thus there must be exactly one value of on-time and one value of off-time for any given output-related value.” *Id.* at 51.

As discussed *supra* in our construction of these terms, we agree that the first and second ranges of feedback values must be non-overlapping because the ranges require different operation of the power supply — i.e.,

fixed frequency in the first range and variable frequency in the second range. However, the first and second ranges of on-time values need not be non-overlapping. In a broad but reasonable interpretation that does not attempt to import limitations of an exemplary embodiment of the Specification, the first and second ranges of on-time value could overlap such that a pulse on-time value may correspond to multiple feedback values in different ranges. Similarly, “function of” need not be limited to a narrow interpretation that requires a function of only a single variable — i.e., a function of only the power supply output feedback value. “Function of,” in accordance with a broad but reasonable interpretation, may encompass functions of multiple variables such as Oda’s function of V_e and V_c that generates an on-time value for each pulse — i.e., Oda generates on-time as a function of both V_e and V_c .

Accordingly, we are not persuaded by the preponderance of the evidence that this Petition should be dismissed or denied based on Patent Owner’s proposed interpretations of “corresponds to” and “function of.”

5. Undisputed Limitations

We have reviewed the Petition’s arguments and evidence in support of Petitioner’s assertions that Oda and Nakamura teach the remaining limitations of claims 31, 32, 34, 38, 39, and 42. Pet. 31–58. Patent Owner does not contest these assertions. *See* PO Resp. 37–46. Based on our review of the Petition, we find persuasive Petitioner’s arguments and supporting evidence, including citations to disclosures of Oda and Nakamura and to Dr. Madisetti’s testimony, and we adopt them as the basis for our

determination that Oda and Nakamura teach these limitations of claims 31, 32, 34, 38, 39, and 42. Pet. 31–58.

6. *Conclusion Regarding Obviousness Over Oda and Nakamura*

For the above reasons, we conclude, by a preponderance of the evidence, that all challenged claims (31, 32, 34, 38, 39, and 42) are unpatentable as obvious over the combination of Oda and Nakamura.

H. *Petitioner’s Motion to Exclude Evidence*

Petitioner filed a Motion to Exclude (Paper 47, “Pet. Mot.”) requesting that we exclude Exhibits 2005–2010, 2014–2016, 2019, 2020, 2031, 2032, 2051–2057, and 2059. Pet. Mot. 1. If Exhibits 2031 and 2032 are not excluded in their entirety, Petitioner requests that we exclude certain identified portions thereof. *Id.* Patent Owner filed an Opposition to Petitioner’s Motion to Exclude (Paper 55) and Petitioner filed a reply thereto (Paper 60).

1. *Exhibits 2005–2010, 2014-2016, 2019, 2020, 2054–2057, and 2059*

Our Decision does not rely on Exhibits 2005–2010, 2014-2016, 2019, 2020, 2054–2057, or 2059 and, thus, with respect to these exhibits, Petitioner’s Motion to Exclude is *dismissed as moot*.

2. *Exhibit 2031*

Regarding Exhibit 2031, Mr. Bohannon’s Declaration, Petitioner argues Mr. Bohannon is not qualified to provide expert testimony and, thus, his entire Declaration should be excluded under Federal Rule of Evidence

(“FRE”) 702. Pet. Mot. 2–10. In particular, Petitioner argues Mr. Bohannon’s testimony is unreliable because it relies on his own alleged expertise in Japanese rather than the translation of record for Oda (Ex. 1029). *Id.* at 7–10.

Mr. Bohannon clearly has technical expertise in the relevant technology and where appropriate we weigh his opinion and expertise against that of Petitioner’s expert (Dr. Madisetti). As to his reliance on his own Japanese language expertise, Petitioner had ample opportunity to, and did in fact, cross-examine Mr. Bohannon regarding the bases of his opinions — both technologically and linguistically. This objection is essentially directed to the weight to be given Mr. Bohannon’s testimony, and not to its admissibility. As the finder of facts, the Board is well-equipped to accord appropriate weight to all admissible testimony in the case. For the foregoing reasons, Petitioner’s motion to exclude Exhibit 2031 in its entirety is *denied*.

3. *Exhibit 2032*

Regarding Exhibit 2032, the Declaration of Mr. Matthews, Patent Owner’s Vice President of Product Development, Petitioner argues various paragraphs of Mr. Matthews’ testimony refer to hearsay to which no hearsay exception applies. Pet. Mot. 10–12. Thus, under FRE 802, Petitioner argues identified paragraphs of Exhibit 2032 should be excluded. *Id.* In particular, Petitioner argues paragraphs 13–15, 17, 26, 29, 31, and 34–37 refer to statements by customers about important features of products or refer to the state of mind of customers in deciding to purchase a product from Patent Owner or from competitors. *Id.* at 10. Petitioner further argues Patent Owner provides no direct testimony from such customers that could be

subjected to cross-examination. *Id.* at 10–11. Furthermore, Petitioner asserts paragraphs 34 and 36 reproduce portions of Mr. Matthews’ testimony during a related litigation that, even if they constitute new testimony (within his Declaration in this proceeding), still refer to customer statements and customer states of mind. *Id.* at 11. Still further, Petitioner asserts paragraphs 8, 10, and 19 of Mr. Matthews’ Declaration refer to prior testimony of other witnesses in prior litigations. *Id.* at 11–12. Petitioner contends all these identified paragraphs are hearsay for which no exception applies and, thus, should be excluded under FRE 802.

Patent Owner argues it is Mr. Matthews’ job to meet with customers to learn what features of a product are important and, thus, customer statements to Mr. Matthews regarding features that are important in a product are not hearsay under FRE 801 because they are not offered for the truth of what they assert — namely what features are important to that customer. Paper 55, 9–10. Patent Owner asserts the fact that a customer tells Mr. Matthews what features are important is relevant evidence of customer demand regardless of whether the customer is telling the truth in the statement to Mr. Matthews. *Id.* at 10. Similarly, Patent Owner asserts customer statements to Mr. Matthews regarding requirements or specifications for products are not hearsay because they are not offered for the truth of the customer’s statement. *Id.* at 10–11. Patent Owner also argues that customer statements about their mental state in making a purchase fall under a hearsay exception FRE 803(3) (“Then-Existing Mental, Emotional, or Physical Condition”). *Id.* Lastly, Patent Owner argues Mr. Matthews’ testimony referring to prior testimony by other

witnesses in prior litigations is not hearsay because Mr. Matthews does not quote that prior testimony. *Id.* at 12.

Petitioner replies that paraphrasing statements or testimony of others rather than quoting such statements or testimony does not exclude such statements or testimony from hearsay. Paper 60, 4. Petitioner further argues Patent Owner's assertion that customer statements regarding important features are relevant to customer demand but are not hearsay is illogical because Mr. Matthews depends on the truth of such statements in assessing customer purchasing decisions. *Id.* Lastly, Petitioner argues that Patent Owner's reliance on the "state of mind" exception to hearsay fails to link any of the challenged paragraphs to a specific category of state of mind as enumerated in FRE 803(3). *Id.*

We agree with Petitioner that portions of paragraphs 13–15, 17, 26, 29, 31, and 34–37 of Mr. Matthews' Declaration that refer to customer statements or the state of mind of customers when purchasing products is hearsay. Mr. Matthews makes these assertions about what customers told him (or told Patent Owner) about important features of power supply controllers, statements outside of this proceeding, to prove what customer's said or believed was important about products — the epitome of hearsay. FRE 801. That paragraphs 34 and 36 are quoting Mr. Matthews' own testimony from a previous proceeding, similarly referring to customers' statements or beliefs, does not exempt those quoted statements from exclusion as hearsay.

Mr. Matthews, in paragraph 8 of his Declaration, makes assertions about things Mr. Balakrishnan said or did in a demonstration of new product designs in a meeting with Dr. Meier. Ex. 2032 ¶ 8 (citing Ex. 2054, 278:18–

280:2). However, Mr. Matthews was not present at that demonstration (Ex. 1072, 35) and, thus, cites only Mr. Balakrishnan's testimony from a previous district court trial about that demonstration (Ex. 2054), as proof of what happened at that demonstration. Similarly, in paragraph 10 of Mr. Matthews' Declaration, he cites a Wall Street Journal article (Ex. 2039) and the prior testimony of Mr. Balakrishnan (Ex. 2054, 295:23–296:6) in support of his assertion that Mr. Balakrishnan met with President Bush to demonstrate certain products of Patent Owner. Ex. 2032 ¶ 10. Again, Mr. Matthews acknowledges he was not present at that meeting (Ex. 1072, 35) and, thus, relies on statements of others, outside of this proceeding, for the truth of what they assert — that such a meeting took place to demonstrate features of Patent Owner's products.

Lastly, in paragraph 19 of Mr. Matthews Declaration, he asserts the number of infringing units sold based on prior testimony of Dr. Jonathan Putnam offered during a district court trial, outside of this proceeding. Ex. 2032 ¶ 19 (citing Ex. 2057, 1149:22–1150:2). Mr. Matthews does not claim to know the number of infringing units sold first hand but, instead, relies on Dr. Putnam's statements made outside this proceeding as proof of the number stated by Dr. Putnam — again, the epitome of hearsay.

For the foregoing reasons, Petitioner's request to exclude identified paragraphs of Exhibit 2032 is *granted*.

4. Exhibits 2051, 2052, and 2053

Exhibits 2051–2053 are dictionary definitions of the word *function* purported to support Patent Owner's interpretation of “function of” in claims 34 and 42. PO Resp. 34. Petitioner argues these dictionary

definitions should be excluded under FRE 401 and 402 as irrelevant because each is dated, on its face, in December 2016 and Patent Owner “has made no attempt to show that these definitions reflect the understanding of [an ordinarily skilled artisan] at the time of the ’079 Patent, which was filed sixteen years earlier on June 30, 2000.” Pet. Mot. 15. We agree that these definitions offer little probative value to define the term *function* as of the date of the ’079 patent. However, we doubt the definition has changed significantly in 16 years. Regardless, Petitioner’s argument essentially addresses the weight to be ascribed this evidence rather than its admissibility. As above, the Board is well-equipped to accord appropriate weight to all admissible testimony in the case. For the foregoing reasons, Petitioner’s request to exclude Exhibits 2051–2053 is *denied*.

J. Patent Owner’s Motion to Exclude Evidence

Patent Owner filed a Motion to Exclude (Paper 49, “PO Mot.”) requesting that we exclude Exhibits 1061, 1063, 1070, 1071, 1075, 1078, and 1081. PO Mot. 1. Petitioner filed an Opposition to Patent Owner’s Motion to Exclude (Paper 56) and Patent Owner filed a reply thereto (Paper 59).

1. Exhibits 1061 (paragraphs 86–93), 1063, and 1078

Patent Owner requests that we exclude paragraphs 86–93 of Exhibit 1061 (Dr. Madisetti’s Reply Declaration), the entirety of Exhibit 1063 (Declaration of Dr. Scott Bennett), and the entirety of Exhibit 1078 (Mr. Kakizaki’s Declaration). PO Mot. 2–7, 10–11. Our Decision does not rely on Exhibits 1063 or 1078 or paragraphs 86–93 of

Exhibit 1061 and, thus, with respect to these exhibits, Patent Owner's Motion to Exclude is *dismissed as moot*.

2. *Exhibits 1061 and 1081*

Patent Owner further requests that we exclude paragraphs 29–36 of Exhibit 1061 (Dr. Madisetti's Reply Declaration) and the entirety of Exhibit 1081 (excerpts of the Mohan textbook) as irrelevant under FRE 401, 402, and 403 because they raise new issues contrary to our rules (37 C.F.R. § 42.23(b) ("A reply may only respond to arguments raised in the corresponding opposition, patent owner preliminary response, or patent owner response.")). PO Mot. 10–12. Specifically, Patent Owner alleges Petitioner's Reply (Paper 37, 10–13) relies on Dr. Madisetti's alleged new legal theory based on his Reply Declaration (Ex. 1061), which is, in turn, based on Mohan (Ex. 1081). *Id.* at 10. Patent Owner alleges Petitioner's Reply asserts "that the limitation previously found to be missing by the Board is actually inherent in Figure 7 of Oda as understood by a person skilled in the art." *Id.* at 11 (citing Paper 37, 10–13; Exhibit 1061 ¶¶ 28–40). Patent Owner alleges this asserts a ground of unpatentability based on anticipation by inherency. *Id.* at 11–12.

We disagree with Patent Owner's contention that Dr. Madisetti's reliance on Mohan raises a new issue. *See* discussion in § II.G.2.b *supra*. Petitioner argued Dr. Madisetti's new reliance on Mohan is in direct response to Patent Owner's arguments in its Response that the shape of the curve plotted in Figure 7 of Oda precludes even a suggestion in Oda that pulse on-time and frequency are both varied in the second range of feedback values. *See* Paper 45, 1 (Response to Patent Owner's list of alleged new

arguments section “Reply § I.C, pp. 10–13”). We agree with Petitioner that the Reply’s reliance on Dr. Madiseti’s Reply Declaration arguments that, in turn, rely on Mohan are in direct response to arguments raised in Patent Owner’s Response. Dr. Madiseti’s Reply Declaration cited new portions of Mohan as background material to support his explanation of the effects of the transfer function of a buck-type converter as seen in Oda’s Figure 7. Other portions of Mohan were already of record, submitted by Patent Owner as Exhibit 2017.

Patent Owner also argues Dr. Madiseti’s Reply Declaration (Ex. 1061) should be excluded under FRE 702–703 because he lacks qualifications as an expert in the relevant technology. PO Mot. 12–14.

Dr. Madiseti clearly has technical expertise in the relevant technology and where appropriate we weigh his opinion and expertise against that of Patent Owner’s expert (Mr. Bohannon). This objection is essentially directed to the weight to be given Dr. Madiseti’s testimony, and not to its admissibility. As the finder of facts, the Board is well-equipped to accord appropriate weight to all admissible testimony in the case.

For the foregoing reasons, Patent Owner’s request to exclude Exhibits 1061 and 1081 is *denied*.

3. *Exhibits 1070, 1071, and 1075*

These Exhibits are all excerpts of prior testimony by witnesses of Patent Owner in prior or pending litigations relating to the ’079 patent. Exhibit 1070 is an excerpt from prior trial testimony by Mr. Balakrishnan. Exhibit 1071 is an excerpt of prior trial testimony by Mr. Renouard. Exhibit 1075 is an excerpt of prior trial testimony by Mr. Matthews.

Petitioner introduced each of these exhibits as alleged impeachment evidence conflicting with testimony in this proceeding by Mr. Matthews.

Patent Owner requests that we exclude all three because they are incomplete records under FRE 106. FRE 106 states in its entirety, “If a party introduces all or part of a writing or recorded statement, an adverse party may require the introduction, at that time, of any other part — or any other writing or recorded statement — that in fairness ought to be considered at the same time.” We understand this rule not as a rule for *exclusion* of evidence but, instead, a rule that allows additional evidence to be offered. Petitioner has introduced a partial prior trial transcript in this matter and, thus, under FRE 106, Patent Owner had the right to introduce other parts of that transcript. In fact, with its Motion to Exclude, Patent Owner has so introduced other portions of those transcripts by including relevant excerpts in its motion.

For the foregoing reasons, Patent Owner’s request to exclude Exhibits 1070, 1071, and 1075 is *denied*.

K. Patent Owner’s Motion to Seal

Patent Owner filed a Motion to Seal (Paper 50) requesting that we seal Exhibit 2064 because lines 3 through 12 on page 30 thereof contain information Petitioner considers confidential. Patent Owner indicates it disagrees with Petitioner’s assertion that the identified material is confidential. Paper 50, 1.

The motion fails to explain sufficiently why the identified material is confidential and, thus, fails to show good cause for sealing the exhibit. Therefore, we deny Patent Owner’s Motion to Seal. However, we note this

IPR2016-00809
Patent 6,212,079 B1

Decision does not rely on the purported confidential information in Exhibit 2064 and Patent Owner has filed a redacted version of the exhibit as Exhibit 2071 with the purported confidential information removed. Thus, we expunge Exhibit 2064 from the record in this proceeding.

III. ORDER

After due consideration of the record before us, and for the foregoing reasons, it is:

ORDERED that claims 31, 32, 34, 38, 39, and 42 of the '079 patent are held *unpatentable*;

FURTHER ORDERED that Petitioner's Motion to Exclude Exhibits 2005–2010, 2014-2016, 2019, 2020, 2054–2057, and 2059 is *dismissed as moot*;

FURTHER ORDERED that Petitioner's Motion to Exclude Exhibits 2031, 2051, 2052, and 2053 is *denied*;

FURTHER ORDERED that Petitioner's Motion to Exclude paragraphs 8, 10, 13–15, 17, 19, 26, 29, 31, and 34–37 of Exhibit 2032 is *granted*;

FURTHER ORDERED that Patent Owner's Motion to Exclude Exhibit 1063, Exhibit 1078, and paragraphs 86–93 of Exhibit 1061 is *dismissed as moot*;

FURTHER ORDERED that Patent Owner's Motion to Exclude Exhibits 1061, 1070, 1071, 1075, and 1081 is *denied*;

FURTHER ORDERED that Patent Owner's Motion to Seal Exhibit 2064 is *denied*;

FURTHER ORDERED that Exhibit 2064 will be *expunged*; and

FURTHER ORDERED that because this is a final written decision, parties to the proceeding seeking judicial review of the decision must comply with the notice and service requirements of 37 C.F.R. § 90.2.

IPR2016-00809
Patent 6,212,079 B1

PETITIONER:

Roger Fulghum
Brett Thompsen
Brian Oaks
BAKER BOTTS L.L.P.
roger.fulghum@bakerbotts.com
brett.thompsen@bakerbotts.com
brian.oaks@bakerbotts.com

PATENT OWNER:

Stephen Schaefer
Neil A. Warren
FISH & RICHARDSON P.C.
IPR10256-0021IP1@fr.com
PTABInbound@fr.com